

Data sheet 100C43.7-53

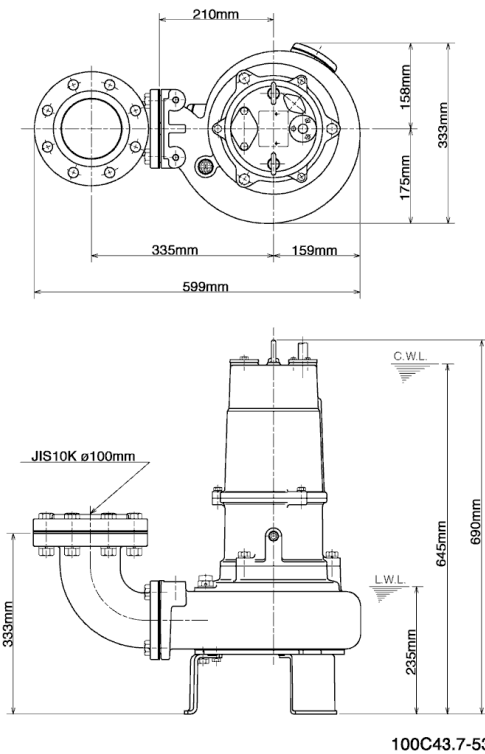

100C43.7-53

CWL: Continuous running water level
LWL: Lowest running water level

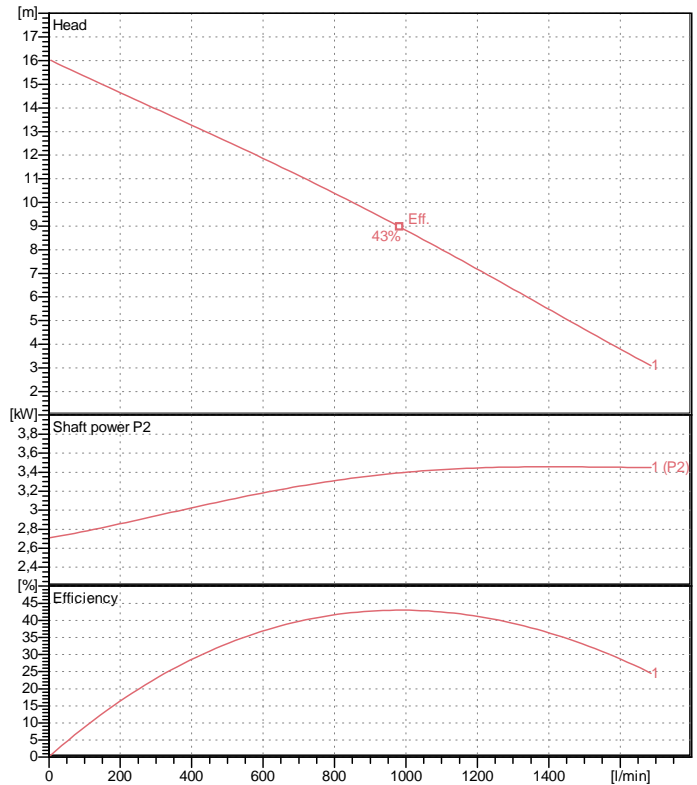

Specification

Electric submersible pump with cutter mechanism
Degree of protection IP 68
Depth of submersion max. 40 m
Type of impeller Single channel impeller
Free passage 60 mm
Suitable for:
sewage water and liquids carrying solids

Electric motor

Dry-type submersible induction motor
Insulation class E 4Poles 1410 1/min
Starting mode Directly
Rated voltage 400 V 50 Hz 3~
Power uptake 4,59 kW
Rated power 3,70 kW
Rated current 7,9 A
Start current 49,0 A

Cable

10m H07RN-F 4Cx1,5mm²

Motor Protection

Miniature protector in windings
(snap-action bi-metal device)

Shaft seal

Double inside mechanical seal in oil bath
additional lubrication by oil lifting device
Primary seal
Silicon carbide on silicon carbide
Secondary seal
Silicon carbide on silicon carbide

Bearings

Shielded ball bearings, maintenance-free

Materials

Impeller
FC20 (EN-GJL-200) + Tungsten carbide
Pump casing FC200 (EN-GJL-200)
Suction cover FCD700 (EN-GJS-700-2)
Motor Frame FC200 (EN-GJL-200)
Shaft Stainless steel SUS420J2

Discharge size

4" (100mm) JIS 10K screwed-in mating flange
guide rail fitting optional

Weight

86 kg (dry weight of the pump only without cable)

Performance curve

100C43.7-53

Discharge port	4"
Head	16,0 m
Flow	1686,7 l/min
Rated power	3,70 kW
Power input	4,59 kW
Phases	3~
Voltages	400 V
Frequency	50 Hz
Rated current	7,9 A
Starting current	48,98 A
Number of poles	4
Speed	1410 1/min
Starting mode	Directly
Insulation class	E

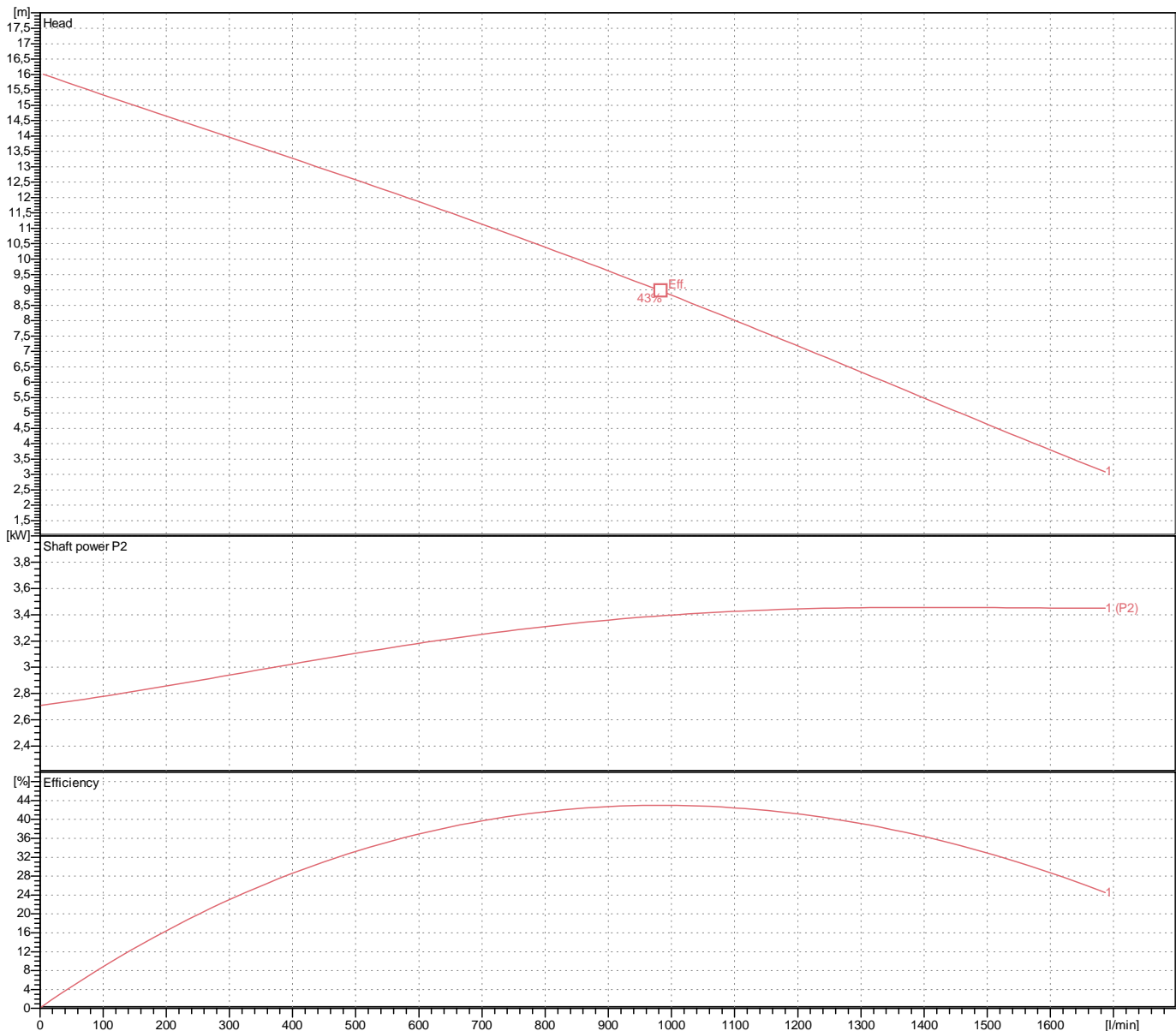

Dimensions 100C43.7-53

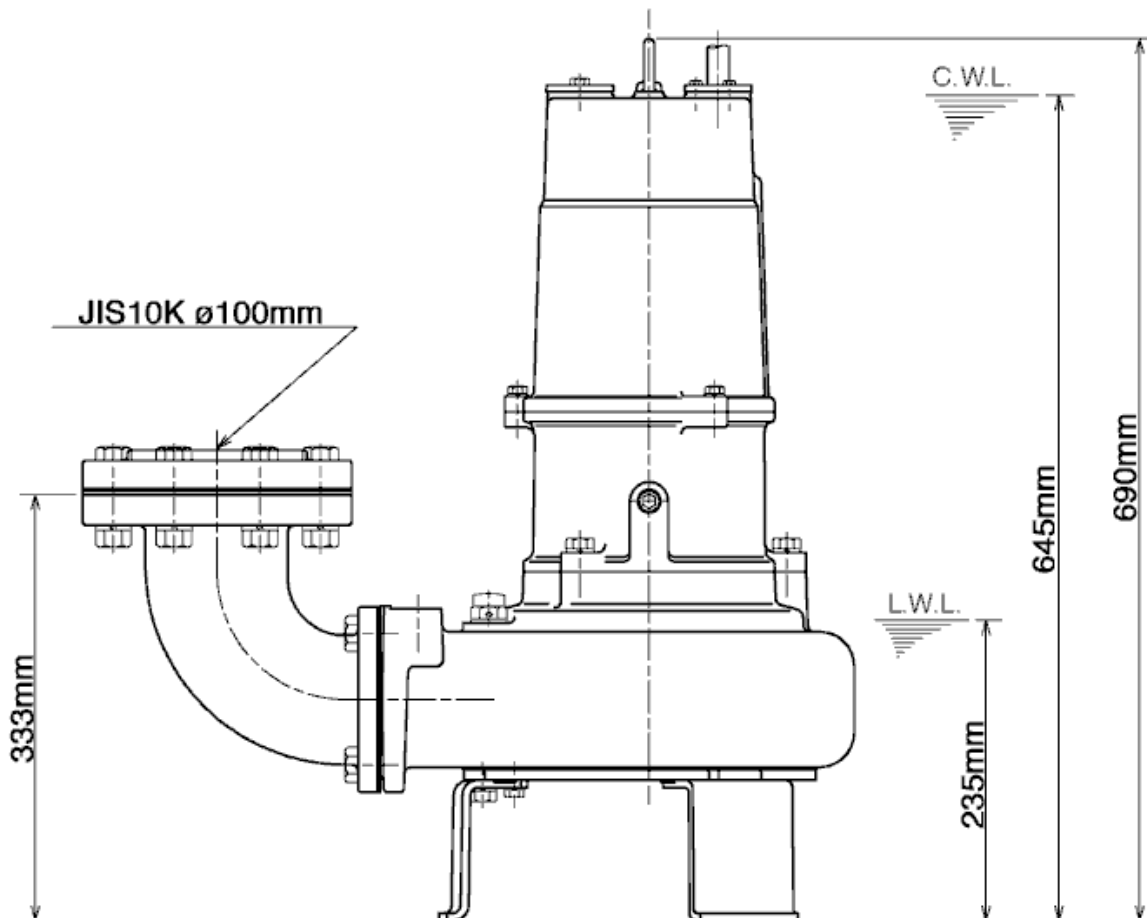
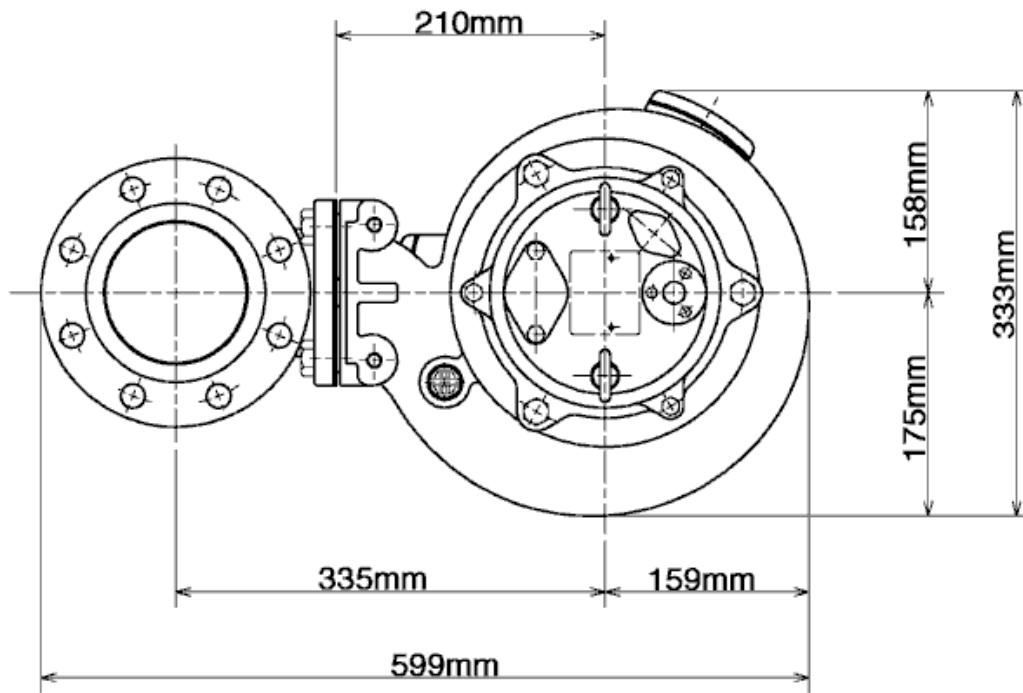

CWL: Continuous running water level
LWL: Lowest running water level

100C43.7-53

Sectional drawing 100C43.7-53

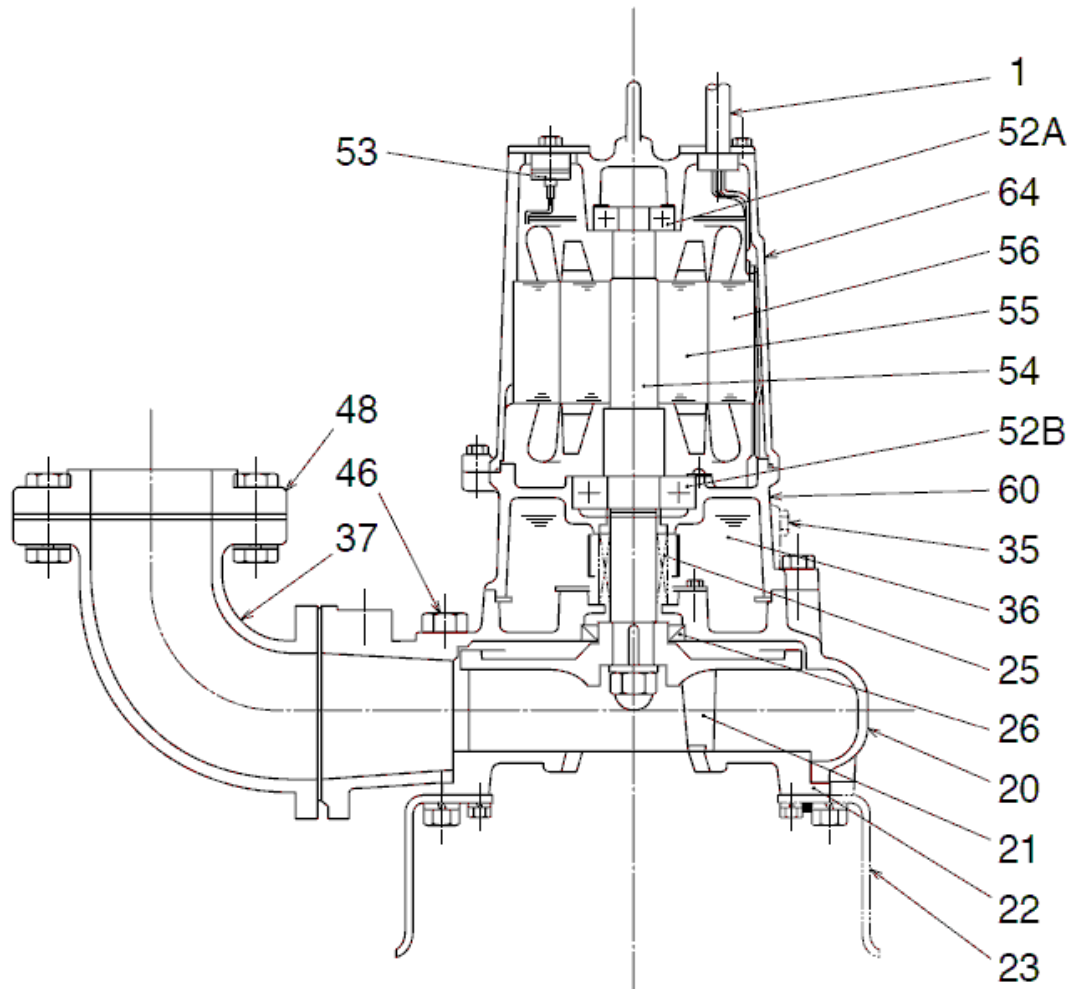

100C43.7-52

No.	Denomination	Remark	No.	Denomination	Remark
1	Cable	H07RN-F	54	Shaft	Stainless steel SUS420J2
20	Pump casing	FC200 (EN-GJL-200)	55	Rotor	.
21	Impeller	FC20 (EN-GJL-200) + Tungsten carbide	56	Stator	.
22	Suction cover	FCD700 (EN-GJS-700-2)	60	Bearing Housing	FC200 (EN-GJL-200)
23	Stand support (3x)	Construction steel SS400	64	Motor Frame	FC200 (EN-GJL-200)
25	Mechanical seal	H-35A	72	Eye screw (2x)	Stainless steel SUS304
26	Oil seal	TC58726			
30	Oil distributor	Plastic			
35	Oil screw	Stainless steel SUS304			
36	Lubricant	Turbine oil (ISO VG32)			
37	Discharge bend	FC200 (EN-GJL-200)			
46	Air vent screw	Nylon			
48	Screwed Flange	FC200 (EN-GJL-200)			
52A	Upper bearing	6304ZZC3			
52B	Lower bearing	6309ZZC3			
53	Motor Protector	.			