

# 232B, 242B

## Skid Steer Loaders



	232B	242B	242B*
Cat® Diesel Engine	3024C	3024C T	3024C T
Net Power	37 kW/50 hp	43 kW/57 hp	43 kW/57 hp
Gross Power	39 kW/52 hp	46 kW/62 hp	46 kW/62 hp
Operating Weight	3021 kg	3085 kg	3127 kg
Rated Operating Capacity	793 kg	907 kg	907 kg

\* High Flow (HF) version



## Caterpillar® 232B and 242B Skid Steer Loaders

*Two versatile compact machines designed, built and backed by Caterpillar to deliver exceptional performance, ease of operation and simplified service.*

### World-class Operator Station

Operator comfort and ease of operation are designed into the operator's station from every aspect. Ergonomic features such as low-effort joystick controls, comfortable padded armrest and an adjustable contoured seat reduce operator fatigue. Excellent visibility to the work tools helps enhance productivity. **pg. 4-5**

### High Performance Power Train

- ✓ The Cat® 3024C engine provides high engine horsepower and torque. Exclusive anti-stall feature maximizes power to the drive train and work tools without stalling the engine, allowing part-throttle operation for lower sound levels and lower fuel consumption. **pg. 6**

### Advanced Hydraulic System

- ✓ The hydraulic system in the Cat Skid Steer Loaders is designed for maximum power and reliability. Increased hydraulic power enables better overall performance. Reduced componentary translates to fewer hydraulic connections thus reducing potential leak points. High Flow hydraulics are optional on the 242B. **pg. 7**

### ***Built for Versatility.***

*The Caterpillar 232B and 242B Skid Steer Loaders are ideal for multiple applications including: construction, landscaping and agriculture. They deliver traditional Cat reliability and durability with excellent productivity.*

✓ *New feature*



---

### Quick Coupler and Cat Work Tools

- ✓ A universal work tool interface and quick coupler make the Cat Skid Steer Loader the most versatile machine on the jobsite. The wide range of Caterpillar work tools optimise machine performance for maximum utility and production. **pg. 9**

---

### Serviceability

- ✓ Cat Skid Steer Loaders offer quick and easy routine maintenance and service. The rear door opens 90 degrees and the cooling package raises to provide industry leading access to the engine compartment. The cab also tilts up for easy access. **pg. 10**

---

### Customer Support

Caterpillar Dealers offer unmatched customer support, with excellent warranty programs and fast parts availability, resulting in maximum uptime and minimum repair costs. Equipment maintenance services help optimize machine performance and reliability. **pg. 11**

---

### Vertical Lift Loader Linkage

Vertical lift loader linkage gives these Skid Steer Loaders more lift height, longer reach at maximum lift height, and a near vertical lift path compared to conventional radial lift machines. Caterpillar vertical lift machines are designed for applications such as lift and place and truck loading. Their longer wheelbase gives greater stability, smoother ride and higher lift capacities. **pg. 8**



## Operator Station

*World-class operator station provides exceptional working comfort with excellent visibility, enhanced fingertip control and optimum instrumentation.*



**Ergonomic Design.** Cat Skid Steer Loaders feature an updated ergonomic cab design that makes operation easier and more comfortable. A choice of contoured, adjustable seats offer increased operator comfort. Careful placement of machine controls make them feel like a natural extension of the operator hands. A new contoured armbar gives excellent support of arms and wrists for easier machine control. The cab features a removable floor mat which acts as a foot rest and offers excellent sound and heat insulation. The foot throttle control is an ergonomically-designed pedal that allows operation at variable engine speeds for optimum performance while minimizing fuel consumption. A standard hand throttle also allows operation at any set engine speed.

**Cab Features.** The ergonomically designed cab provides the operator with easy to use pilot controls in a comfortable working environment. The standard offerings of the Cat Skid Steer Loaders operator station include:

- 12 volt power socket
- Removable, sliding side windows
- Enclosed cabs feature an automatic lock-out switch which prevents accidental damage by disabling the loader functions when the door is open.

### **Low-Effort Machine Controls.**

Ergonomic pilot-operated hydraulic controls give operators precision control of Cat Skid Steer Loaders with minimal effort. The left joystick controls forward and reverse travel speed plus direction and the right joystick controls loader up/down and tilt control. Both joysticks use an intuitive “S” control pattern. Joysticks provide additional auxiliary controls, using positive-action buttons to provide precision fingertip control of many machine functions, including:

- One-touch continuous auxiliary hydraulic flow
- Momentary auxiliary hydraulic flow
- Multiple auxiliary functions
- Horn
- Proportional auxiliary hydraulic functionality (optional)





### High-efficiency Climate Controls.

Operating in extreme temperatures is now more comfortable with the optional cab air conditioner and heater installed. The air conditioner offers 14 250 kj cooling capacity and the heater output is 18 690 kj. Six adjustable vents provide excellent air flow throughout the cab and makes defrosting the optional front door and side windows easier. (Air conditioning available on the 242B only.)

**Visibility.** The Cat Skid Steer Loader has a wide cab opening providing exceptional view of the work tool enhancing ease of operation and productivity. The sloped angle of the engine compartment allows excellent visibility to the rear of the machine. A new convex rearview mirror option gives the operator a panoramic view of the rear and sides of the machine. For better visibility in low-light conditions, the standard forward lights are adjustable 10 degrees in any direction.

**Instrumentation.** Cat Skid Steer Loaders use instrument panels and gauges that are simple, easy-to-use and reliable. Bright indicator lights and audible warning, signals any critical system situation. An engine air cleaner restriction indicator is situated in the cab for easier reference.

**Access/Egress.** The Cat Skid Steer Loader cab is designed to make machine operation simple, productive and comfortable. Getting into and out of the cab is secure and easy through a wide opening with three-point grab handles and skid-resistant steps. Tilt cylinders are neatly located under the lift arms so not to interfere with operator access and egress.



**Cab Packages.** Several cab packages and options are available.

The standard cab includes:

- ROPS/FOPS cab
- Contoured cushion seat with fore/aft adjustment
- Retractable seat belt
- Cushioned, contoured armbar
- Dual throttle controls - hand and foot
- Dome light
- Horn
- Rear wall liner
- Windows, top and rear
- Two overhead instrument panels
- Pilot-hydraulic joystick and fingertip auxiliary controls
- 12 Volt power socket

The deluxe cab package includes items in the standard cab, plus:

- Deluxe suspension seat
- Headliner
- Additional working lights

A cold-weather cab package includes items in the standard cab, plus:

- Removable, sliding side windows
- High-efficiency heater/defrost
- Engine coolant heater
- Heavy-duty 880 CCA starting battery
- Debris barrier

Other cab options include:

- Cab door (either glass or polycarbonate) with wiper/washer and loader arm lock-out
- Air conditioner with heater/defrost
- FOPS, Level II
- Insulated floor mat with foot rest
- Cup holder
- 76 mm seat belt
- Additional controls for
  - hydraulic quick coupler
  - proportional auxiliary hydraulics
  - work tool electrical requirements

## Power Train

*Caterpillar Hystat power train delivers aggressive performance and easy operation.*



### **Cat Diesel Power.**

The heart of the Cat Skid Steer Loader power train is the Caterpillar 3024C diesel engine, which is turbocharged in the 242B model. This rugged, reliable four-cylinder Stage II compliant Cat engine offers aggressive performance and a fast torque curve for quick response.

### **Throttle Control.**

Dual engine throttle controls allow the operator to match engine speed to the task. The hand throttle is ideal for jobs requiring consistent engine speed - such as cold planing or trenching. The foot throttle enables the operator to vary engine speed and minimize fuel consumption for other tasks such as load and carry, truck loading, grading and dozing.

**Anti-Stall System.** An exclusive anti-stall system on the Cat Skid Steer Loaders allows maximum power to the wheels while minimizing engine stalling. This exclusive system helps maximize productivity for experienced operators and makes it easier for novice operators to become productive.

**Axial Piston Pumps.** Dual, variable-displacement axial piston pumps are driven directly off the engine and provide hydraulic flow to the drive motors via a closed loop system. Drive motors transfer mechanical power to the wheels via two high-strength, pre-stressed chains per machine side. Chains run in an oil bath for constant lubrication and long life. Chains are adjustable through slots in the axle housings.

**Drive Axles.** Drive axles are forged and induction hardened for maximum life. They include a unique labyrinth seal which consist of lip and outer seal to help prevent debris such as wire and twine from wrapping around the axle and destroying the seal. An inner seal is used for permanent lubrication of axle bearings - no daily axle service is required.



## Hydraulic System

*Hydraulic system has built-in reliability and provides exceptional wheel torque plus lift, breakout and auxiliary power to work tools.*

**High-Flow Hydraulics.** Optional high-flow hydraulics provide increased hydraulic horse power for high-speed, high-power work tools such as cold planers, landscape rakes, stump grinders and trenchers. This system can be ordered on new Cat 242B machines or can be installed later by your local Cat Dealer.

**Front Hydraulics.** Standard ON/OFF front hydraulics are featured on the 232B and 242B. Optional proportional front auxiliary hydraulics are also available on these models.

**Power and Reliability.** Maximum power and reliability are built into the Cat Skid Steer Loader hydraulic system. In addition to providing power to drive the wheels, this system also provides the loader lift and tilt functions, powers the auxiliary circuit to drive work tools and drives the engine cooling fan.

**Hydraulic Pumps.** Hydraulic pumps are driven directly off the engine for maximum hydraulic performance and reliability - no belts are used. Pumps are open center, fixed-displacement and provide flow to the loader and auxiliary hydraulic circuits. Control of the loader lift and tilt functions by hydraulically-operated pilot controls enable low-effort and precise operation.

**Auxiliary Hydraulics.** Standard auxiliary hydraulics to power work tools is available through quick-connect hydraulic couplings that are rigidly mounted to the loader arm. Cat XT hose and O-Ring Face Seals help ensure a leak-free system.



### **Reliability and Cleanliness.**

Reduced potential leak points improve reliability and result in a cleaner machine. In addition, hydraulic oil flows through a 4-micron spin-on filter. A filter restriction indicator is located at the operator station. A 74-micron screen in the hydraulic tank prevents larger debris from entering the system and causing damage to the hydraulic components.

### **Hydraulic Oil Cooler.**

A high-efficiency hydraulic oil cooler enables the Cat Skid Steer Loader to work longer and harder in higher ambient temperatures, even when using continuous high flow work tools. The high-capacity hydraulic oil reservoir maintains lower operating temperatures.

## Vertical Lift Loader Linkage

*Innovative loader design offers high lift height, extended reach and near-vertical lift path.*



**Vertical Lift Linkage.** The 232B and 242B Skid Steer Loaders feature vertical lift loader linkage that provides excellent loader performance and durability without excess weight. This innovative design allows the machines to endure the punishment of heavy digging with minimal linkage wear.

### **Two Additional Links Per Side.**

They allow the loader arms to move forward during the lift cycle. This provides fifty-five percent more reach when fully raised, compared to a conventional radial lift loader. When lowered, reach is the same as a radial lift design to help maintain good ride characteristics during loaded carry.

**Lift Arms.** The loader arms are extremely robust with a large torque tube at the rear. This makes the vertical linkage system exceptionally rigid. This rigidity increases the service life of the machine and minimizes downtime.

**Longer Wheelbase.** A longer wheelbase gives these machines increased load-carrying capacity and gives them a smoother ride. It also improves weight distribution of the machine for higher lift capacities.

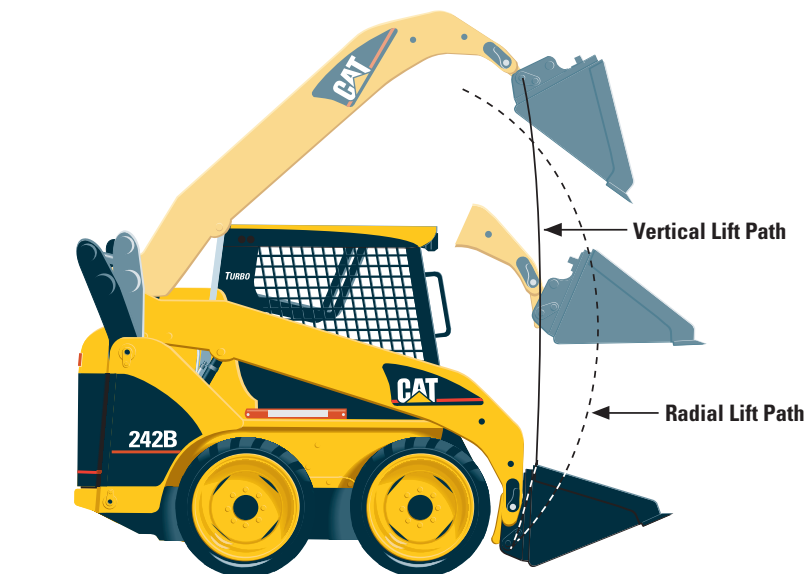



# Quick Coupler and Caterpillar Work Tools

*Choose from a wide variety of tools that are performance matched to Cat Skid Steer Loaders*

**Quick Coupler.** Work tools can be changed quickly and easily with the Cat Skid Steer's quick coupler system. The universal coupler interface features:

- Low profile side plates are designed for the optimum match to work tools and minimal material packing
- Opposing wedges ensure a tight tool fit
- Rugged design and large contact area absorbs loads and minimizes stress
- Tool engagement and release are quick and easy
- Vertical pins are chrome-plated and lubricated for smooth engagement and prevention of corrosion
- Coupler allows excellent visibility to work tools and unobstructed entry and exit to the cab.

The standard quick coupler features manual engagement and disengagement of work tools using two high-leverage handles. An optional hydraulic quick coupler is also available and allows engagement and disengagement of work tools without the need for the operator to exit the machine. Control of the coupler by use of a rocker switch inside the cab, making work tool changes quicker and easier.

**Cat Work Tools.** They extend the versatility of the Cat Skid Steer Loaders. Designed and built for optimum performance and durability, these tools deliver high productivity, long service life and excellent value:

- Angle blades
- Augers
- Backhoes
- Brooms
- Buckets:
  - general purpose
  - grapple
  - light material
  - multi purpose
  - utility
- Cold planers
- Compactor vibratory
- Hammers
- Landscape rakes
- Landscape tillers
- Material handling arm
- Pallet forks
- Stump grinders
- Trenchers



## Serviceability

*Quick access and superior design make the Cat Skid Steer Loaders easy to maintain.*

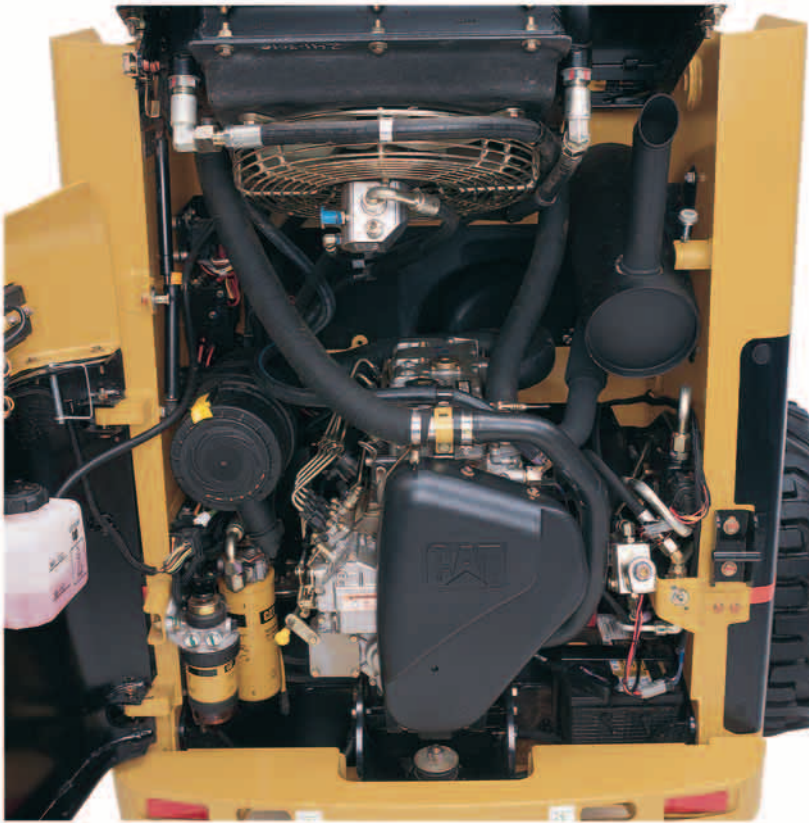

**Service Access.** The rear service door opens 90 degrees for easy access to both sides of the in-line mounted engine.

**Filters.** All filters are spin-on and easily accessible, which makes routine service quicker and virtually spill-free.

**Cooling System.** The radiator, hydraulic oil cooler and grill tilt up to increase access to the cooling system during maintenance and allows easier cleaning of debris from between the grill and cooling package. The cooling fan is hydraulically driven for quieter operation and to eliminate the service and maintenance that comes with belt-driven fans.

**Easy Tilting Cab.** The machine cab can now be tilted rearward by a single person using a single tool, and is held in place by a self-latching mechanism. When the cab is tilted back, all hydraulic pumps, motors, valves, lines and the fuel tank are accessible for quick, easier service.

**Removable Belly Pan.** A removable belly pan section on the floor of the machine's lower frame provides excellent access for periodic cleaning.

### **Electrical and Hydraulic Lines.**

Clean routings of electrical and hydraulic lines improves reliability and simplifies service.

**Maintenance Points.** They are grouped in easily accessible locations.

**S•O•S<sup>SM</sup> Valves.** Scheduled Oil Sampling S•O•S valves are standard to allow regular monitoring of the engine and hydraulic oil quality.

### **Other Standard Service Features**

- Easy access to battery, air filter and single engine belt
- Sight glass on hydraulic tank and radiator allow quick, easy level checks
- Air filter restriction indicators are located inside the operator station and at the air filter
- Ecology drains simplify changing engine and hydraulic oils
- Grease fittings are countersunk to prevent damage
- Extended life coolant and 250-hour engine oil change intervals





## Complete Customer Support

*Cat dealer services help you operate longer with lower costs.*

**Machine Selection.** With nine different Cat Skid Steer Loader and four Cat Multi Terrain Loader to choose from, selecting the right machine is even easier when you consult your Caterpillar dealer. Your dealer helps you make detailed machine comparisons before you purchase.

**Purchase Options.** Available to let you look beyond just the initial machine price. With your Cat dealer, you can review available financing options plus look at day-to-day operating costs. You can also look at dealer services that can be included in the cost of the machine to yield lower equipment owning and operating costs over the life of the machine.

### **Customer Support Agreements.**

These agreements offer you a variety of service and maintenance options that can be customized to best fit your specific requirements. These can cover the entire machine and include work tools to help protect your investment.

**Machine Support.** It is one of your Cat dealer's primary goals. You will find high availability of parts at our Dealer parts counter. Cat Dealers utilize a worldwide computer network to find in-stock parts to minimize machine downtime. Your Cat dealer can also save you money by suggesting Cat Remanufactured parts that carry the same warranty as new, but with savings of 40 to 70 percent.

### **Maintenance Service Plans.**

Help manage machine maintenance, by choosing from a wide range of maintenance plans and services at the time you purchase a machine. Repair option plans guarantee the cost of repairs up front. Diagnostics programs such as Scheduled Oil Sampling, Coolant Sampling and Technical Analysis help you avoid downtime and unscheduled repairs.



**Operator Training.** Cat dealers can improve your operator's techniques and help boost your profits.

### **Cat Machine Security System.**

Secure your investment with Caterpillar's Machine Security System (MSS), a programmable key system that provides maximum machine security for Cat Skid Steer Loader owners.

- MSS disables machine by interacting with the machine's Electronic Control Modules (ECM)
- Keys fit all existing Cat machines (including machines without MSS)
- Each machine can store up to 50 key identifications
- Each key can be configured to operate a certain range of machines or enable operation for a certain period of time

### **Repair, Rebuild or Replace.**

Choices become even more evident when you consult your Caterpillar dealer. Your Cat dealer can help evaluate the costs involved so you can make the right choice every time.

## Engine 3024C

	232B	242B
Ratings at 2600 rpm	kW/hp	kW/hp
Net power	37/50	43/57
Gross power	39/52	46/62

### Dimensions

Bore	84 mm	84 mm
Stroke	100 mm	100 mm

- Caterpillar 3024C (232B) and 3024C T turbocharged (242B), water-cooled, four-stroke cycle, four-cylinder diesel
- Net power rating per ISO 9249 or EEC 80/1269
- Meets EU directive 97/68/EC Stage II emission requirements

## Operating Specifications

The specifications for the 232B and 242B Skid Steer Loaders are with standard tyres, dirt bucket, full fuel 65 kg and a 75 kg operator.

	232B	242B	*242B
	kg	kg	kg
Rated operating capacity**	793	907	907
Rated operating capacity with optional counterweight**	815	928	928
Operating weight	3021	3085	3127
Tipping load	1588	1814	1814
Breakout force			
lift cylinder	1742	1742	1731
tilt cylinder	1841	1841	1841

\* High Flow (HF) version

\*\* ISO 5998:1986

## ROPS/FOPS

Rollover Protective Structure (ROPS) and Falling Objects Protective Structure (FOPS).

- ROPS meets ISO 3471:1994
- FOPS meets ISO 3449:1998 Level I
- FOPS Level II (optional) meets ISO 3449:1998 Level II

## Hydraulic System

	232B	242B	*242B
Hydraulic Flow	Std	Std	HF
Loader			
Hydraulic pressure (kPa)	21 400	23 000	23 000
Hydraulic Flow (l/min)	60	60	100

### Features

- Single, hydraulically-operated joystick controls lift, lower and tilt functions
- Open center, fixed displacement

\* High Flow (HF) version

## Power Train and Brakes

Dual, closed-loop, axial piston hydrostatic pumps driven directly off engine. Pumps provide pressure and flow to two fixed displacement motors.

	232B	242B	*242B
Travel speed	km/h	km/h	km/h
Forward	11.1	12.0	12.0
Reverse	11.1	12.0	12.0

### Features

- Single hydraulically-operated joystick, controls speed and direction
- Hydrostatic service brakes
- Multi-disc, spring-applied hydraulically released parking brake
- Anti-stall system maximizes torque to the wheels without stalling engine

\* High Flow (HF) version

## Sound

### Operator Sound

- The operator sound level measured according to the procedures specified in ISO 6396 is 89 dB(A).

### Exterior Sound

- The labeled spectator sound power level measured according to the test procedures and conditions specified in 2000/14/EC is 104 dB(A).



## Dimensions

Dimensions are based on 232B equipped with 10 x 16.5 8 PR Cat Premium Conventional tyres and 1524 mm dirt bucket.

242B dimensions are based on 12 x 16.5 10 PR tyres and a 1676 mm dirt bucket.

The specification for the 232B and 242B Skid Steer Loaders are static and conform to ISO 5998:1986.

All dimensions are approximate.

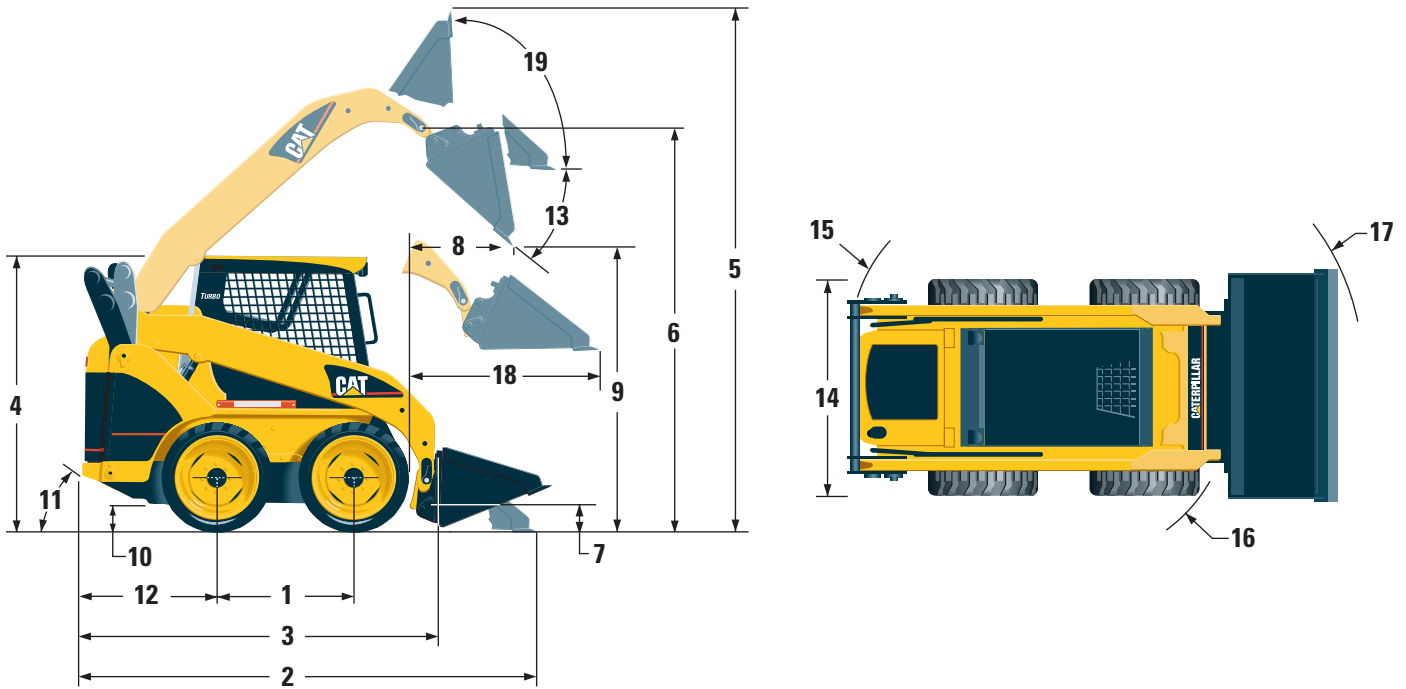

	232B mm	242B mm
1 Wheelbase	1094	1094
2 Length with bucket on ground	3437	3437
3 Length without bucket	2760	2760
4 Height to top of cab	1953	1986
5 Max overall height	3894	3926
6 Hinge pin height at max lift	3013	3045
7 Hinge pin height at carry position	247	299
8 Reach at max lift and dump	766	766
9 Clearance at max lift and dump	2243	2270

	232B mm	242B mm
10 Ground clearance	145	178
11 Departure angle	28°	28°
12 Bumper overhang behind rear axle	989	989
13 Maximum dump angle	50°	50°
14 Maximum width over tires	1524	1676
Turning radius from center		
15 left	1545	1545
16 right	1409	1409
17 full	2221	2221
18 Reach with level arms and bucket	1231	1231
19 Rack back angle at max height	87°	87°

## Service Refill Capacities

	Liters
Chain box, each side	6
Cooling system	10
Engine crankcase	8
Fuel tank	65
Hydraulic system	55
Hydraulic tank	35

## Standard Equipment

Standard equipment may vary. Consult your Caterpillar dealer for specifics.

Air cleaner, dual element, radial seal  
Alternator  
  232B: 65-amp  
  242B: 85-amp  
Armrest, pull down  
Battery, 12-volt, 650 CCA  
Brake, parking, SAHR  
Cleanout, belly pan  
Controls, pilot-operated, hydraulic  
Coupler, mechanical, quick  
Ecology drains: engine, hydraulic oil and coolant  
Electric Socket, 12-volt  
Engine, diesel:  
  232B: Cat 3024C naturally-aspirated  
  242B: Cat 3024C T turbocharged  
Falling Object Protective Structure, Level I  
Fan, hydraulically-driven  
Filter  
  fuel, bayonet-type  
  hydraulic, spin-on, 4 micron  
Fuel/water separator, spin-on  
Hydraulics, auxiliary, front, ON/OFF  
Hydraulics, continuous flow  
Instrumentation:  
Audible:  
  – engine coolant temperature  
  – engine oil pressure  
  – hydraulic oil temperature  
Gauges:  
  – fuel level  
  – hour meter, digital  
Indicators:  
  – air filter restriction  
  – alternator output  
  – armrest raised/operator out of seat  
  – engine coolant temperature  
  – engine oil pressure  
  – hydraulic filter restriction  
  – hydraulic oil temperature  
  – parking brake engaged

Muffler  
Precleaner, self-unloading  
Pump, hydraulic implement  
Pump, hystat charge and hydraulic fan  
Rear view mirror, internal  
Safety control interlock system  
Scheduled Oil Sampling (S•O•S) valves  
Seat, static  
Seat belt, retractable, 50 mm  
Sight gauge, coolant and hydraulic oil  
Starting aid, glow plugs  
Support, lift arm  
Switch, ignition  
Tail lights  
Throttle controls, hand and foot  
Tie-downs, front and rear  
Valve, hydraulic, three-section  
Windows, top and rear



### Low Side Wall.

The Cat LSW offers exceptional puncture resistance and run-flat capability. Ideal for general construction and heavy-duty applications.



### Premium Conventional.

The Cat Premium Conventional tyre are equipped with the industry's deepest tread depth, thickest sidewall and heaviest rim guard. Provides optimum performance in a variety of applications.



## Optional Equipment

Optional equipment may vary. Consult your Caterpillar dealer for specifics

Air conditioning with heater/defrost (242B only)  
Alarm, back up  
Battery, 12-volt, 880 CCA  
Control, work tool, electrical  
Counterweight, adds 45 kg to ROC  
Coupler, hydraulic  
Cup holder  
Debris barrier for cab  
Door, front  
    laminated glass with wiper/washer  
    polycarbonate with wiper/washer, for demolition use  
Falling Object Protective Structure, Level II,  
    attaches to existing FOPS  
Floor mat  
Headliner  
Heater/Defrost, cab  
Heater, engine coolant  
Horn  
Hydraulics, auxiliary, front, proportional  
Hydraulics, auxiliary, front, proportional,  
    High Flow (242B only)  
Hydraulics, self leveling, lift  
Lifting provisions:  
    – four-point, or  
    – single-point  
Lights, front and rear, working  
Light, warning beacon  
Machine Security System (MSS)

Seat, suspension  
Seat belt, 76 mm  
    for static seat  
    for suspension seat  
Synthetic hydraulic oil for cold weather operation  
Windows, side, sliding, removable  
  
Tires:  
    10 x 16.5 8 PR 1524 mm (60 in)  
        Caterpillar Premium Conventional  
    265-521 8 PR 1524 mm (60 in) Caterpillar Low Side Wall  
    10 x 16.5 6 PR 1524 mm (60 in) GY SGL  
    10 x 16.5 8 PR 1524 mm (60 in) GY IT323  
    10 x 16.5 8 PR 1524 mm (60 in) GALAXY  
    10 x 16.5 8 PR 1676 mm (66 in)  
        Caterpillar Premium Conventional  
    265-521 8 PR 1676 mm (66 in) Caterpillar Low Side Wall  
    10 x 16.5 6 PR 1676 mm (66 in) GY SGL  
    10 x 16.5 8 PR 1676 mm (66 in) GY IT323 (232B only)  
    31 -15.5 x 16.5 8PR 1676 mm (66in) Caterpillar (232B only)  
    10 x 16.5 8 PR 1676 mm (66 in) GALAXY  
    10 x 16.5 10 PR 1676 mm (66 in) MICHELIN (232B only)

The following tire options are available on the 242B only:  
8 x 16 Solid 1524 mm (60 in) Caterpillar  
12 x 16.5 10 PR 1676 mm (66 in) GY SGL  
12 x 16.5 10 PR 1676 mm (66 in) GY IT323  
12 x 16.5 10 PR 1676 mm (66 in) Galaxy  
12 x 16.5 10 PR 1676 mm (66 in)  
    Caterpillar Premium Conventional  
12 x 16.5 10 PR 1676 mm (66 in)  
    Caterpillar Premium Conventional with Poly-Fill\*  
12 x 16.5 12 PR 1676 mm (66 in) Michelin  
33-15.5 X 16.5 12 PR 1676 mm (66 in) Caterpillar  
305-546 10 PR 1676 mm (66 in) Caterpillar Low Side Wall

\* For best performance, SuperFlex Poly-Fill should only be used on firm surfaces and is not recommended for use with optional counterweight.



### Premium Conventional Flotation.

The Cat Premium Conventional Flotation tyre is most efficient on soft terrain.



### Extreme Duty Solid.

The Cat Solid tyre performs on the toughest applications. Profitability is improved through the elimination of downtime and repair costs. Ideal for foundry and demolition job-sites.

# 232B and 242B Skid Steer Loaders

HEHL3006 (05/2004) hr

Materials and specifications are subject to change without notice.  
Featured machines may include additional equipment.  
See your Caterpillar dealer for available options.

[www.CAT.com](http://www.CAT.com)  
© 2004 Caterpillar

