

Bergmann Dumper

3012 R_{PLUS}



Wheel dumper | cab
Swivel Tip



- High stability thanks to oscillating axle
- Swivelling operator's stand
- Electro hydraulic spring type cylinder park brake
- Compact dimensions and low weight

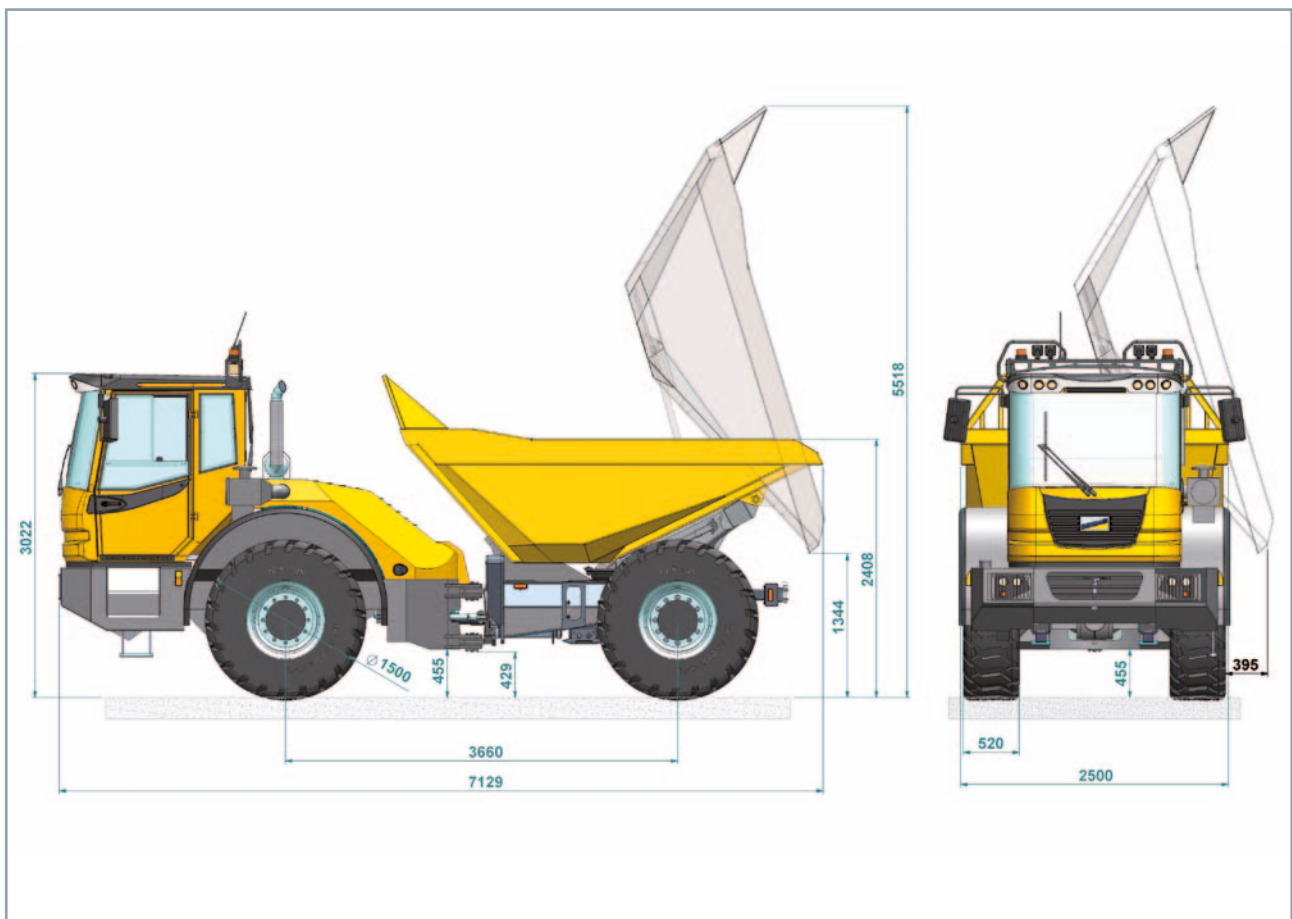

BERGMANN

3012 R_{PLUS} Technical Data



Wheel dumper | cab
Swivel Tip

Weight/Bucket Capacity

payload	12.000 kg
empty weight	11.140 kg
loading capacity struck	6,3 m ³
loading capacity heaped	8,0 m ³
bucket system	hydraulical swivel tip

Dimensions

clearance height	3.022 mm
tipping height	1.344 mm
loading height (front)	2.408 mm
total length	7.129 mm
total width	2.500 mm
ground clearance	429 mm

Transmission

load-depending shift – manually shiftable by hand and automatically, self-adjusting optimisation of traction force and speed, speed control stepless forward and backwards, ZF-Ergo-Power transmission	
1. gear f/b	6/6 km/h
2. gear f/b	9/15 km/h
3. gear f/b	14/33 km/h
4. gear f	21 km/h
5. gear f	32 km/h
6. gear f	40 km/h

Steering

hydraulical articulated steering acting over priority valve
articulation: 37° left & right

Axles/Brakes

suspended front axle, rear axle fix, maintenance-free-oil-bath multi-disc brake in the wheel hubs with self-locking differential with a locking value of 45 %, hydraulically applicated spring-type cylinder locking brake acting over articulated shaft on front and rear axle

Engine

4 cylinder Cummins diesel engine – water cooled –
power 119 kW with 2.200 rpm
Tier IV Interim

Tyres

standard 20.5-25 double coin

Bonnet

easy access to all maintenance and service points thanks to wide opening sectioned bonnet

Tank Capacity

fuel	190 L
hydraulic oil	80 L

Electrics

24 V electric system with main switch, fault finding modus, fuel and hour counter, control lamps for engine oil; park brake, driving display, battery charging control, hydraulic filter, display for drive position

Standard Equipment

comfortable driver's cab with air-suspended driver's seat, swivelling operator's stand, lighting system according to German traffic regulations, hardox plates in the bucket, flashing yellow light, cigarette lighter, roller blind for front windscreen, device for radio, loudspeaker and antenna, EC declaration of conformity