

6R SERIES

NOW WITH COMMANDPRO



JOHN DEERE

NOTHING RUNS LIKE A DEERE

NOW WITH COMMANDPRO

MASTER THE POWER AND TECHNICAL SOPHISTICATION OF
THE 6R WITH OUR REMARKABLE OPERATOR INTERFACE.





CONTENTS

| | |
|---|----|
| Introduction | 2 |
| Overview | 4 |
| 6R Small Frame Tractors | 10 |
| 6R Mid Frame Tractors | 12 |
| 6R Large Frame Tractors | 14 |
| 6R Xtra Large Frame Tractors | 16 |
| Outstanding Efficiency | 18 |
| Engine | 20 |
| Transmissions | 22 |
| CommandPRO Joystick | 26 |
| Cab | 28 |
| Comfort and Stability | 32 |
| Illumination | 34 |
| Hitches | 36 |
| Hydraulics and PTO | 38 |
| Front Loaders | 40 |
| Agricultural Management Solutions | 44 |
| Connected Farm Management | 48 |
| Services | 50 |
| Specifications | 52 |

YOUR VERSATILE WORKFORCE

Every 6R tractor is designed and engineered to be the most versatile and powerful constituent of your workforce, built to overcome the diverse challenges presented by terrain, prevailing conditions and operational windows.



4 | ENGINE PERFORMANCE

The 4.5 l or 6.8 l John Deere engines with up to 250 hp rated power give you fantastic power at reduced operating costs.

5 | TRANSMISSIONS

Semi-automatic AutoQuad Plus, super efficient & powerful DirectDrive and efficient stepless AutoPowr.

6 | AXLES AND TYRES

TLS PLUS and Variable Ratio Steering in the front axle for outstanding comfort. Large tyres at the back for maximum pull.



8 | OUTSTANDING CAB

Extra spacious 3.33 m³ very quiet 71 dB(A) cab, manufactured to automotive industry standards.

9 | COMMANDPRO

Perfect ergonomics, driving strategy and reconfigurability.

10 | ISOBUS AND GUIDANCE

Versatile ISOBUS on the CommandCenter, plus our popular AutoTrac guidance system.

7 | STRONG HYDRAULICS

Up to six rear selective control valves (SCVs) and 160 l/min hydraulic flow.

GOT FRONT LOADER WORK?

This tractor's short wheelbase and open view cab will have you moving about nimbly while doing all the heavy lifting you've got for it.



11 | CONNECTIVITY INSIDE

JDLINK enables remote servicing and operator support.

ENGINE PERFORMANCE

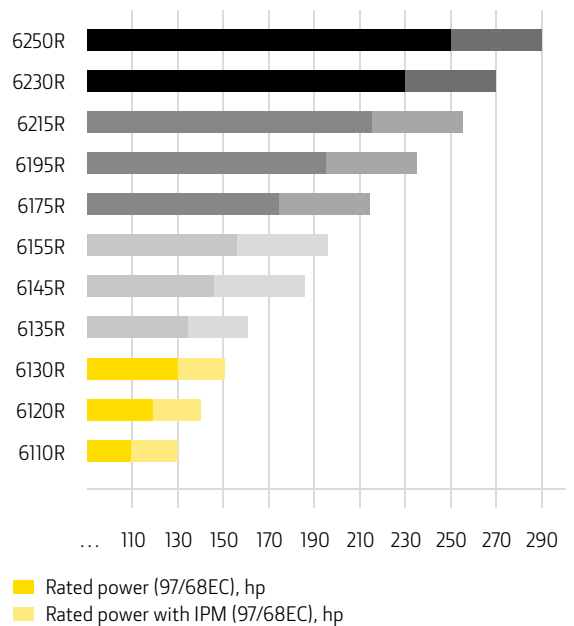

GETTING THINGS DONE

You'll master even the toughest days on the biggest jobs with the 6R's awesome power and comfortable ride – at a level of efficiency that seeks its equal.



1 | PULLS MORE

Less power losses and more pulling power. That's the 6R difference.

2 | COMFORT

TLS Plus front axle Suspension and HCS Plus cab suspension work together to provide the best ride and drive experience.

3 | LOW COST OF OWNERSHIP

Low fuel consumption, low maintenance and repair costs and a very strong resale value guarantee the best value for money.

WHICH 6R IS YOURS?

Finding your 6R is easy. Whether you are a livestock farmer, arable farmer, mixed farmer or run a contracting business – one of these tractors was made for you.



MAXIMUM DURABILITY

The John Deere full frame design forms the rugged backbone of all 6R Series tractors. Engine and transmission are mounted within the frame on insulating blocks that reduce stress and operating noise. It's the perfect platform for a John Deere front loader.

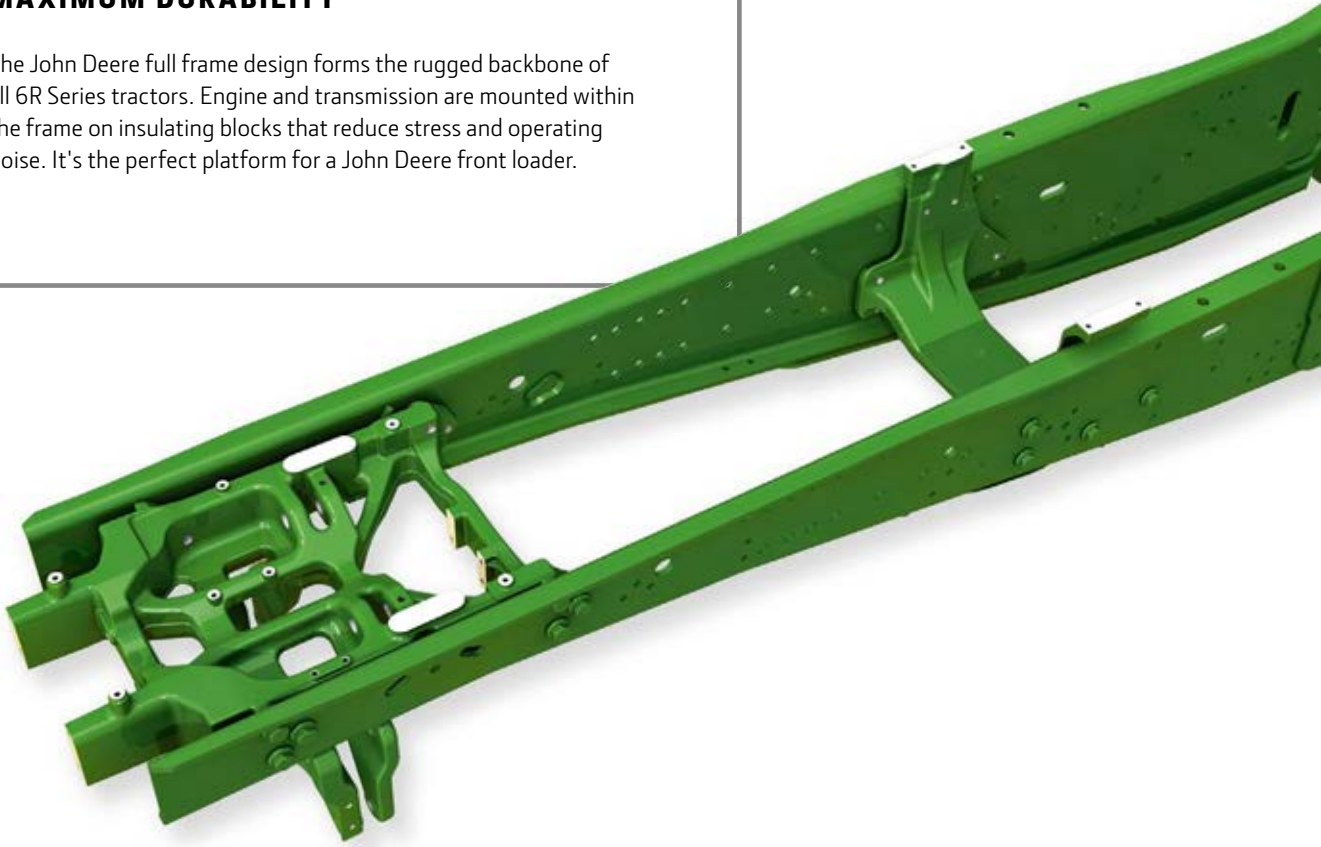

SMALL FRAME: COMPACT AND AGILE

Great for livestock operations – mowing, tedding, baling and feeding. The short wheelbase and open view cab make it ideal for front loader work.



**XTRA-LARGE FRAME:
LIGHT. STRONG. SMART.**

More power on the front PTO and increased lift capacity at the front and in the back – ready for the heavy stuff.



**MID FRAME:
VERSATILE AND STRONG**

Earns its keep in ag operations from small to large because it's strong enough to handle even heavier field work such as seeding and tillage.



**LARGE FRAME:
THE POWER TO PERFORM**

For the heavy-duty end of the work spectrum with top on-road performance requirements, you can't do better than these. Contractors take note!



6R SMALL FRAME TRACTORS

COMPACT AND AGILE



WEIGHT & DIMENSIONS

Sure to fit through any of your barn doors and easy to manoeuvre anywhere you need to go for your front loader work – the short wheelbase makes it possible.

6,100 KG

Shipping weight (measured with average specifications)

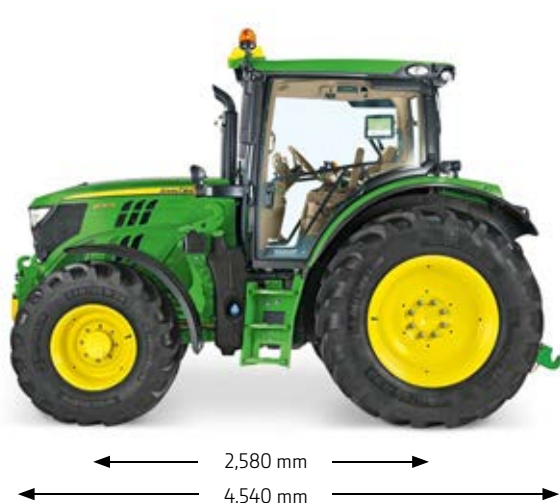

ENGINES

| | 6110R | 6120R | 6130R |
|--|----------|-----------|-----------|
| Cylinders | 4 | 4 | 4 |
| Displacement (l) | 4.5 | 4.5 | 4.5 |
| Rated power (ECE-R120), hp (kW) | 110 (81) | 120 (88) | 130 (96) |
| Rated power with IPM (ECE-R120) @ 2,100 1/min, hp (kW) | 130 (96) | 140 (103) | 150 (110) |
| Emission standard | Stage V | Stage V | Stage V |



4.5 L POWER-TECH PSS 4-CYLINDER ENGINE

TRANSMISSIONS



PowrQuad – 4 gears/
6 groups (24/24)



AutoQuad – 4 gears/
6 groups (24/24)



AutoPower – IVT

Rely on our proven PowrQuad Plus and AutoQuad Plus transmission systems or choose top-of-the-line AutoPower for superior operational ease combined with the best fuel efficiency.

*With 540/65R24 front tyres and 600/65R38 rear tyres

6R MID FRAME TRACTORS

VERSATILE AND STRONG



WEIGHT & DIMENSIONS

Our mid frames sit in the spot between agility and powerful performance – ready for anything.

7,000 KG**

Shipping weight (measured with average specifications)



ENGINES

| | 6135R | 6145R | 6155R |
|--|-----------|-----------|-----------|
| Cylinders | 4 | 6 | 6 |
| Displacement (l) | 4.5 | 6.8 | 6.8 |
| Rated power (ECE-R120), hp (kW) | 135 (99) | 145 (107) | 155 (114) |
| Rated power with IPM (ECE-R120) @ 2,100 1/min, hp (kW) | 165 (122) | 185 (136) | 195 (144) |
| Emission standard | Stage V | Stage V | Stage V |



**6.8 L
POWER-TECH
PVS
6-CYLINDER
ENGINE**

TRANSMISSIONS



PowrQuad – 4 gears/
6 groups (24/24)***



AutoQuad – 4 gears/
5 groups (20/20)***



DirectDrive – 8 gears/
3 groups (24/24)***



AutoPowr – IVT

*With 540/65R28 front tyres and 600/65R38 rear tyres
 **6135R: 6,400 kg
 ***6135R: 24/24 PowrQuad and AutoQuad Transmissions; DirectDrive not available.

6R LARGE FRAME TRACTORS

THE POWER TO PERFORM



WEIGHT & DIMENSIONS

The large wheelbase provides a rock solid and comfortable ride in a wide range of field applications and transport scenarios.

8,400 KG

Shipping weight (measured with average specifications)



ENGINES

| | 6175R | 6195R | 6215R |
|--|-----------|-----------|-----------|
| Cylinders | 6 | 6 | 6 |
| Displacement (l) | 6.8 | 6.8 | 6.8 |
| Rated power (ECE-R120), hp (kW) | 175 (129) | 195 (143) | 215 (158) |
| Rated power with IPM (ECE-R120) @ 2,100 1/min, hp (kW) | 215 (158) | 235 (173) | 255 (188) |
| Emission standard | Stage V | Stage V | Stage V |



**6.8 L
POWER-TECH
PVS
6-CYLINDER
ENGINE**

TRANSMISSIONS



PowrQuad – 4 gears/
5 groups (20/20)



AutoQuad – 4 gears/
5 groups (20/20)



DirectDrive – 8 gears/
3 groups (24/24)



AutoPowr – IVT

*With 600/70R30 front tyres and 800/70R38 rear tyres

6R XTRA LARGE FRAME TRACTORS

LIGHT. STRONG. SMART.



WEIGHT & DIMENSIONS

The even longer wheelbase (+100 mm) and the enormous 2.05 m tyres help get the awesome power of the extra-large frame models to the ground with total efficiency.

9,300 KG

Shipping weight (measured with average specifications)

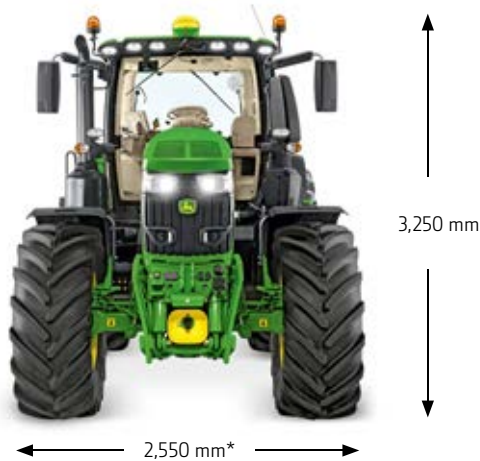
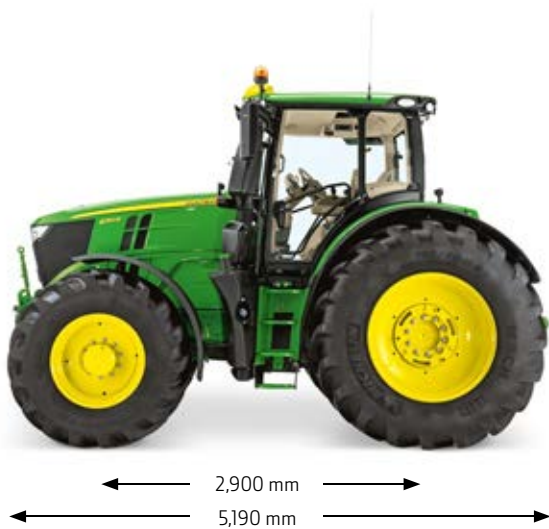

ENGINES

| | 6230R | 6250R |
|--|-----------|-----------|
| Cylinders | 6 | 6 |
| Displacement (l) | 6.8 | 6.8 |
| Rated power (ECE-R120), hp (kW) | 230 (169) | 250 (184) |
| Rated power with IPM (ECE-R120) @ 2,100 1/min, hp (kW) | 270 (199) | 290 (213) |
| Emission standard | Stage V | Stage V |



**6.8 L
POWER-TECH
PSS
6-CYLINDER
ENGINE**

TRANSMISSIONS



AutoPowr – IVT

The superior ease of operation of our top-of-the-line AutoPowr transmission complements the power and torque of your 6R – experience outstanding fuel efficiency and exceptionally high levels of operating comfort.

*With 600/70R30 front tyres and 800/70R38 rear tyres

OUTSTANDING EFFICIENCY

How much power does a tractor actually deliver?
 Engine specification in the market can be deceiving.
 What matters is not the engine power or the
 decal on the bonnet, it's the power that can be
 transmitted to the ground or to the PTO.



6250R DLG POWERMIX TRANSPORT 2.0

Get all the power you need and save big on fuel: Tested according to the PowerMix Transport 2.0 procedure (Status 1.8.2018), the 6250R delivered the lowest fuel consumption compared to the competitors tested.

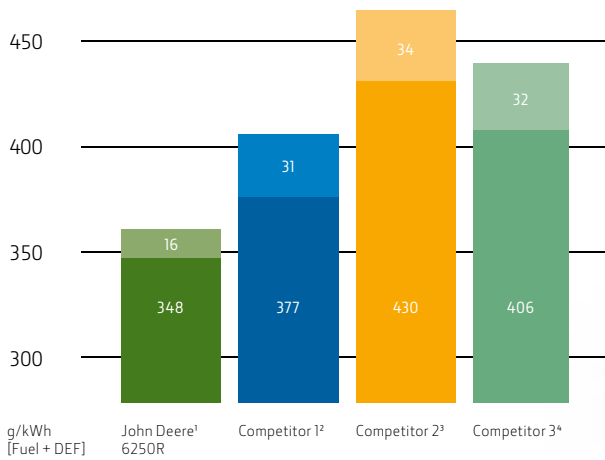

¹ Profi Test Results 06/2018, Page 12
² Profi International Test Results 05/2018, Page 12
³ Profi International Test Results 07/2018, Page 14
⁴ Profi International Test Results 06/2018, Page 14

THE 6R DELIVERS OVER 93% OVERALL TRACTOR EFFICIENCY



ENGINEERED FOR EFFICIENCY

Large surface cooling package (1) with better airflow. High torque and excellent fuel economy at rated speeds and maximum efficiency transmissions (2). Superior axle design and wide, up to 2.05 m tyres (3) help put all that power to the ground.

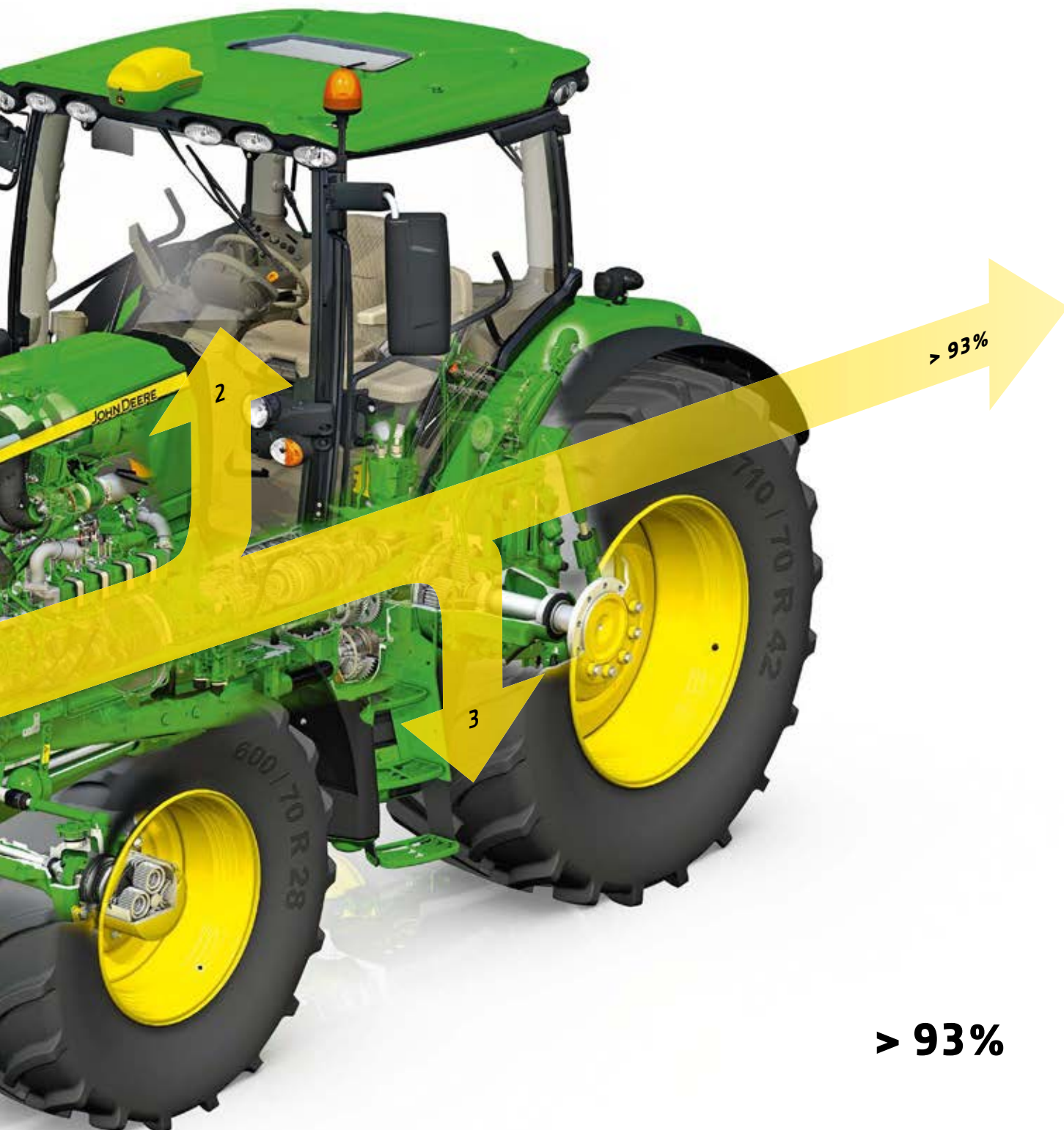

POWER WITHOUT LIMITS

Get all the power you need with less fuel and lower emissions from our renowned 4.5 l 4 cyl. engine or the 6.8 l 6 cyl. engines (Stage V compliant). All our 6 cyl. engines feature extended drain intervals of up to 750 hours.*

ENGINE RESPONSIVENESS

The diesel particulate filter (DPF) not only traps particles it also improves the transient response for better throttle responsiveness.

COOLED EXHAUST GAS RECIRCULATION (EGR)

Precise amounts of cooled exhaust gases are mixed with incoming fresh air, lowering combustion temperatures. This leads to less NOx output from the engine and more efficient timing, which promotes both fuel and DEF economy.

SELECTIVE CATALYTIC REDUCTION (SCR)

Diesel exhaust fluid mixes with engine exhaust gases in the catalyst to reduce further NOx. The DEF consumption is just 2-3% of diesel use.

SERIES TURBOCHARGERS

The series turbochargers deliver more low-speed torque and engine responsiveness to meet varying load requirements.



Our 4.5 l PSS engines (6110R, 6120R, 6130R and 6135R) use a 2-stage turbocharging system in which the VGT multiplies the pressure created by a fixed vane turbocharger. This sequential arrangement boosts power to achieve up to 166 hp (max with IPM) in the 6135R.

*with John Deere Plus-50 II

**LONG 750 H OIL
CHANGE INTERVAL***

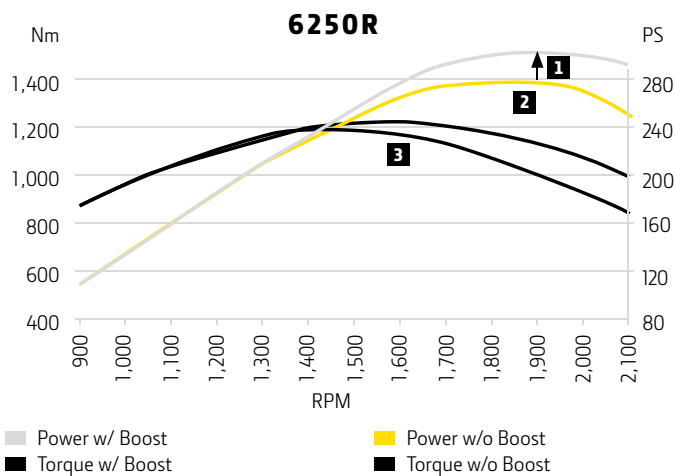
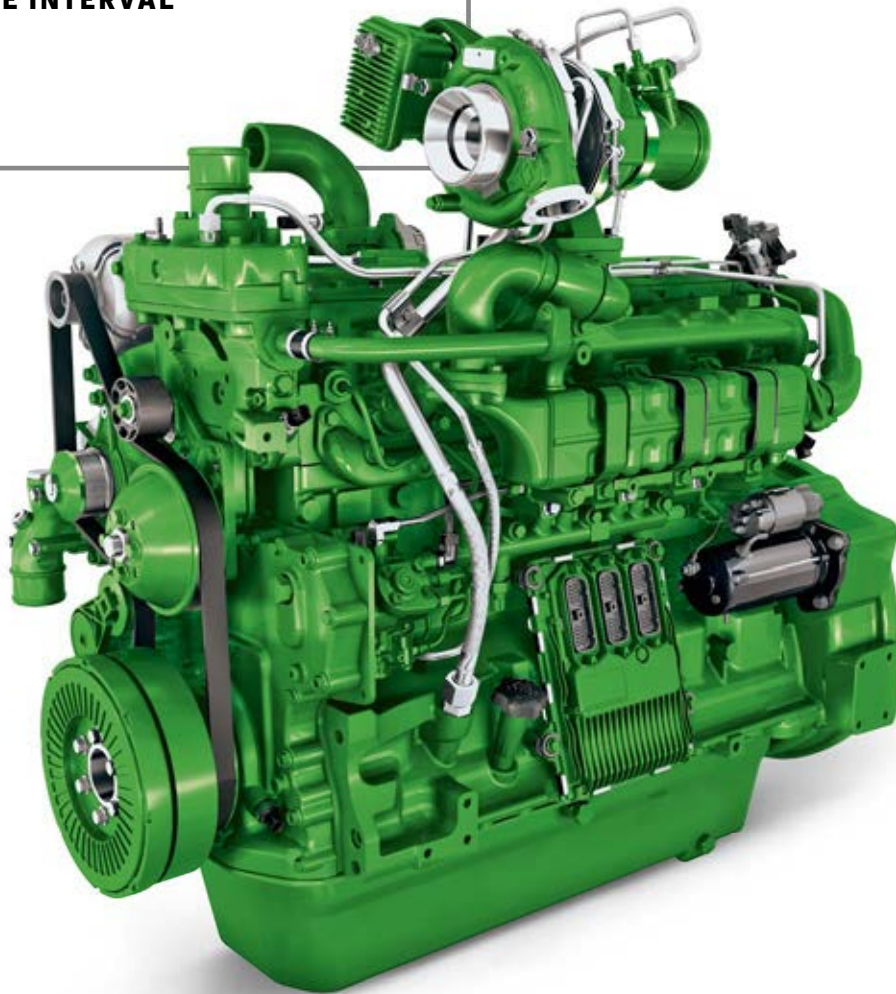

The higher power output of our 6-cyl. engines comes from refined 4-valve High Pressure Common Rail technology with injection pressure of up to 2,500 bar. The PVS engine in the 6145R-6215R has a Variable Geometry Turbocharger which boosts performance and efficiency across the torque curve. The PSS engines (6230R and 6250R) use a 2-stage turbocharging system in which the VGT multiplies the pressure created by a fixed vane turbocharger.

Intelligent Power Management (1) provides up to 40 additional hp for transport and PTO applications. Max. power (2) and max. torque (3) are achieved at 1,900 and 1,600 rpm respectively to ensure optimum response with low fuel consumption levels.

POWRQUAD PLUS AND AUTOQUAD PLUS

PROVEN TRANSMISSION TECHNOLOGY

Our proven PowrQuad Plus and AutoQuad Plus transmissions provide superior ease of operation to complement the power and torque of your 6R.

Both transmissions can be ordered with a creeper option for small and mid-frame models to achieve speeds as low as 72 m/h at 1,000 rpm.



POWRQUAD PLUS

We offer two versions, 20/20 and 24/24, with availability depending on tractor model. All provide rapid shifting including speed matching when shifting between ranges. They are operated by a single range lever with declutch function and push-button gear selection. SoftShift technology keeps the changes smooth, even under load.



AUTOQUAD PLUS

All the benefits of PowrQuad Plus with the added convenience of automatic gear shifting and a maximum speed of 50 km/h. 20/20 and 24/24 versions are available. With the EcoShift option a transport speed of 40 km/h is maintained at only 1,533 rpm, reducing fuel consumption and emissions.

DIRECTDRIVE

ADVANCED DUAL CLUTCH TECHNOLOGY

Specifically developed for 6R tractors, DirectDrive is an eight-speed, three-range transmission designed and engineered by John Deere for heavy agricultural work.



1 | Clutch 1: Shifting of even gears
2 | Clutch 2: Shifting of odd gears

SEAMLESS EFFICIENCY

Dual-clutch technology always lines up the next gear so that no momentum is lost during changes – reducing fuel consumption and enhancing ease of operation.

BETTER FUEL ECONOMY

During transport, DirectDrive reduces the engine speed to 1,550 rpm at 40 km/h and 1,600 rpm at 50 km/h for significantly reduced fuel consumption.

STOP-AND-GO EASE

The AutoClutch function lets you stop the tractor without pressing the clutch – it makes a huge difference if you do a lot of stop and go work.

- 1 | Speed wheel
- 2 | Shift lever
- 3 | Automatic mode
- 4 | Manual mode
- 5 | Range selection



| | | | | | | | | | | | | | | | | | |
|-----------|-----|-----|-----|-----|-----|-----|-----|------|----|----|----|----|----|----|----|----|----|
| | 2.7 | 3.3 | 4.1 | 4.9 | 6.0 | 7.3 | 8.9 | 10.8 | | | | | | | | | |
| A | 1 | 2 | 3 | 4 | 5 | 6 | 7 | 8 | | | | | | | | | |
| | | | | | 5.4 | 6.6 | 8.1 | 9.8 | 12 | 15 | 18 | 22 | | | | | |
| B | | | | | 1 | 2 | 3 | 4 | 5 | 6 | 7 | 8 | | | | | |
| | | | | | | | | | | 16 | 20 | 25 | 30 | 36 | 44 | 54 | 54 |
| BC | | | | | | | | | | 1 | 2 | 3 | 4 | 5 | 6 | 7 | 8 |

■ Speed ■ Gear

DirectDrive offers 11 gears between 4 and 12 km/h thus ensuring the optimum gear/rpm combination regardless of the situation.

AUTOPOWER

INFINITE SPEED ADJUSTMENT

AutoPowr is a hydro-mechanical transmission that delivers stepless and continuous power at speeds between 50 m/h and 50 km/h.

COMFORT

AutoPowr maintains the selected speed by automatically responding to changing load conditions.

FUEL ECONOMY

Once running at maximum road speed, engine rpm automatically drops to the minimum level required to maintain that speed – reducing noise and saving fuel. 50 km/h is maintained at 1,630 rpm, 40 km/h at 1,300 rpm with CommandPRO. AutoPowr comes standard in 6230R and 6250R tractors.

TWO CONTROL LAYOUTS

With AutoPowr, superior efficiency comes as standard. Controlled with CommandPRO it also brings ultimate convenience.



- 1 | Set-speed adjusting wheel
- 2 | Speed band two
- 3 | Speed band one

**FINALLY, ULTIMATE
CONVENIENCE ALSO
MEANS SUPERIOR
EFFICIENCY**

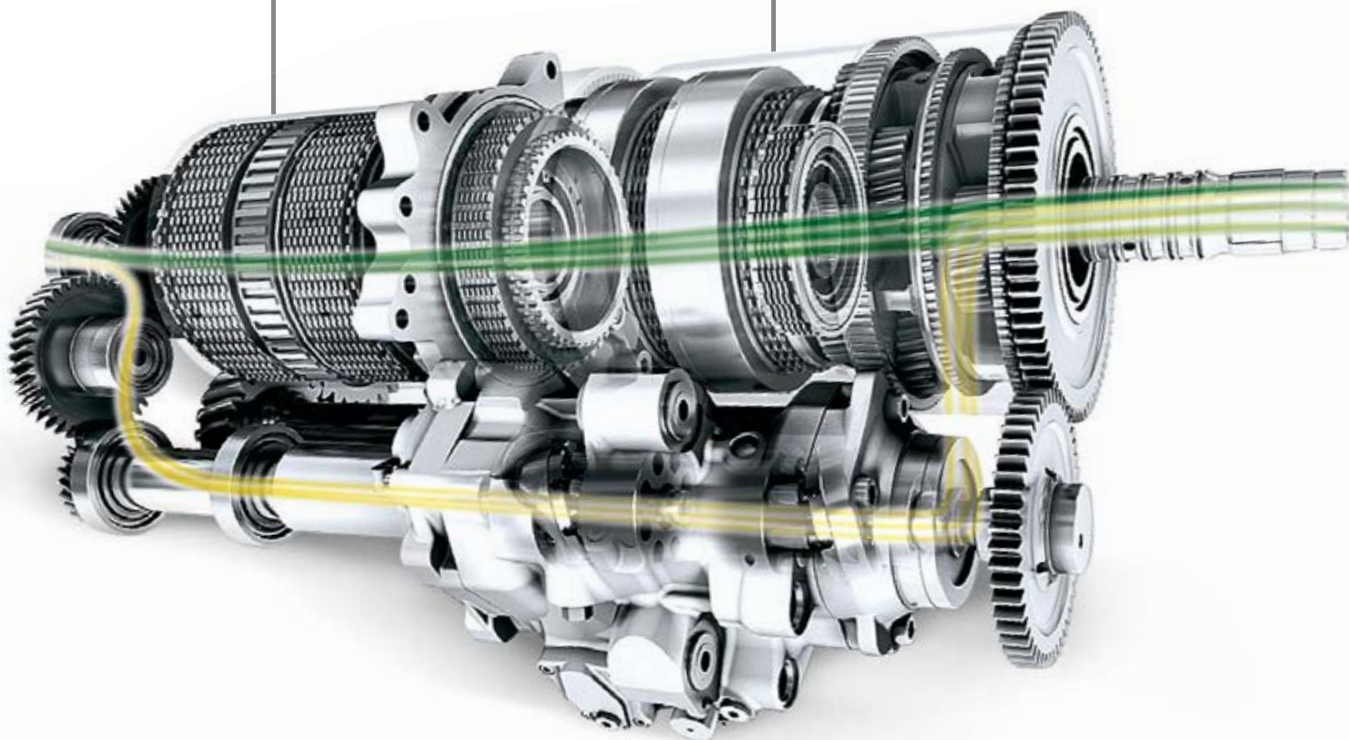

■ Mechanical power
■ Hydrostatic power

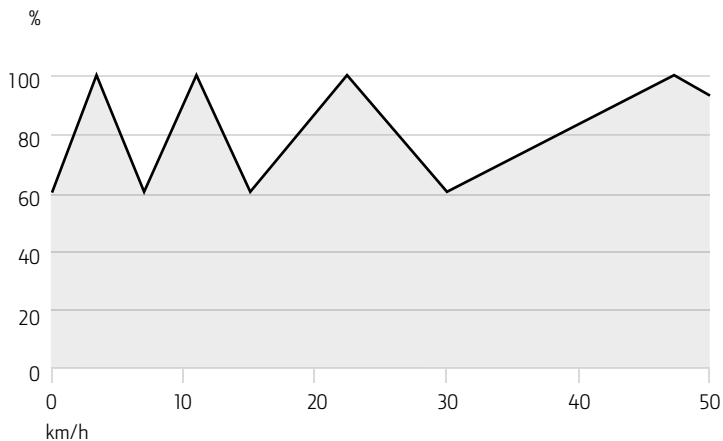

MAXIMUM EFFICIENCY

AutoPowr delivers 100% mechanical power at the following working speeds: 3.5 km/h (heavy draft), 11 km/h (light draft), 22.5 km/h (heavy transport) and 47.2 km/h (light transport). This results in superb transmission efficiency, close to that of mechanical transmissions. In fact, AutoPowr is always using more than 60% of the available mechanical power.

COMMANDPRO JOYSTICK

Mastering the power of the 6R Series tractors is simple with the new CommandPRO joystick and its 11 reconfigurable buttons. It's the ultimate driver interface for making every work day even more comfortable and productive.

THE ULTIMATE DRIVER INTERFACE

- Set top and zero speeds with one simple push or pull
- Creeping control from 0 to 2 km/h
- Simultaneously active pedal and joystick driving
- ActiveZero function keeps the output speed actively at 0 km/h until the acceleration command is given
- Control ISOBUS implements with CommandPRO



SETTINGS MANAGER

Reducing the set-up time for all your applications, the Settings Manager allows you to save machine settings such as engine, SCVs and rear hitch, as well as configuration settings for the electronic and CommandPRO joysticks. Instantly access the individual settings for implements or operators and be productive from the moment you take the wheel.



CREEPING CONTROL

TOP SET SPEED



Accelerate

ACTIVATE SET SPEED

SELECT DIRECTION

Decelerate

ZERO SPEED



1 | Travel set speed buttons 1 and 2

2 | Acceleration response button with three settings

3 | Travel speed adjustment wheel

4 | Activation button

5 | 11 Reconfigurable buttons for:
– Front/Rear Hitch
– Front/Rear PTO
– SCV's
– iTEC
– AutoTrac
– ISOBUS functions
– Engine set speed

DO YOUR BEST WORK EVER

You'll sit down, you will look around, and you will know it: I'm going to get things done here. Better, faster, more efficiently. At a quiet 71 dB(A), you'll enjoy our roomy 3.33 m³ cab every time you get in.

1 | DOORS YOU DON'T SEE

Our panorama doors don't look like much. That's a good thing. You'll enjoy the unobstructed view through them. A left-hand side B-post version is also available.

2 | STORAGE TO UNCLUTTER YOUR CAB

There are probably several items you want to have along. You'll have convenient access to them without them cluttering your cab. Also available as a fridge.

3 | BLUETOOTH RADIO

Provides Bluetooth telephone connectivity with SIM card access via the CommandCenter.



4 | SIT BETTER

Premier seats for less fatigue, more productivity. Options include a swivelling air suspended seat and the Ultimate Seat with Active Climate System.



Superior operator convenience – the CommandARM with 4200 or 4600 CommandCenter.



6 | COMMANDARM AND GENERATION 4 COMMANDCENTER

Your tractor as a seamless extension of you: Intuitively control SCVs, AutoTrac, iTEC, A/C, lights, radio, 4WD and hitch depth control. Monitor everything and control it all with effortless precision.



7 | ELECTRONIC RECONFIGURABLE JOYSTICK

Improved productivity that's easy to set-up and use. The ISOBUS capable joystick is available with the right-hand console and the CommandARM – its functions easily reconfigured via the Generation 4 CommandCenter.

GENERATION 4 COMMANDCENTER

Finally, the swiping ease of use you enjoy on your tablet comes to your cab.

ISOBUS AEF CERTIFIED

Switching between implements becomes easy with our fully ISOBUS AEF certified CommandCenter Displays.

| | 4200 COMMANDCENTER | 4600 COMMANDCENTER |
|--|--------------------|--------------------|
| Touchscreen | 21.3 cm (8.4") | 26.4 cm (10") |
| Tractor Controls | ■ | ■ |
| Documentation | ■ | ■ |
| AutoTrac | ■ | ■ |
| ISOBUS AEF - UT, AUX-N, TC-SC, TC-BAS, TC-GEO | ■ | ■ |
| Wireless Data Transfer and Remote Display Access | ■ | ■ |
| Video inputs | 1 | 4 |



DAILY SERVICE CENTRE

Get an instant overview of fluid level status at the touch of a finger. The Daily Service Centre removes the need to manually check engine oil and engine coolant levels – stay clean, save time.



MORE SCREEN, MORE CONTROL

The new Gen4 Extended Monitor doubles the screen area so you can monitor and control more functions simultaneously – like viewing vehicle control functions on your primary display and Precision Ag applications on the Extended Monitor.



5 | MORE FEATURES FOR LESS

What others might charge for or can't do comes as standard on the 4200 CommandCenter: ISOBUS AEF, variable rate application, full documentation, upgrade options to AutoTrac and Section Control, plus Remote Display Access and Wireless Data Transfer support. Wow!

**MORE CONTROL,
BETTER CONTROL:
JUST SWIPE**

GREAT RIDE, ALL THE POWER

The Triple Link Suspension Plus not only guarantees optimum traction and field performance, it also applies up to 10% more power to the ground.

It also ensures higher operator comfort, reduces operator fatigue and increases productivity, while Variable Ratio Steering improves in-field manoeuvrability.



Variable Ratio Steering off

Variable Ratio Steering on



VARIABLE RATIO STEERING

Improves operator comfort, requiring less hand movement and less steering effort when turning on the headland or working with a loader in confined spaces. The resulting faster turning of the steering wheel increases hydraulic flow, leading to quicker response of the tyres. Available for all 6R models.

ENHANCED OPERATOR COMFORT

The intelligent hydro-pneumatic cab suspension (HCS Plus) offers more driving comfort in the field and on the road. Input from the acceleration and TLS sensor causes the cab suspension controller to increase or decrease the amount of oil in the shock absorber ram. This semi-active system delivers ultimate comfort in every situation.



ADAPTIVE FRONT AXLE

The self-levelling TLS Plus automatically adjusts sensitivity and suspension rate, and synchronises with hitch sensing to compensate power hop under heavy pull conditions.

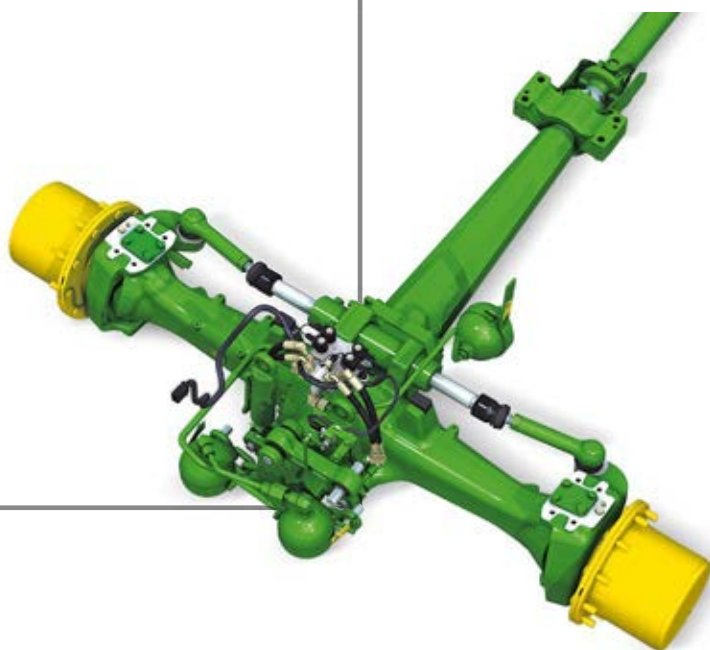



LIGHT UP THE NIGHT

Nature has never respected normal working hours. Keep your operations productive even at night, with 360° visibility provided by up to 12 cab lights.

PRE-SETS FOR PRODUCTIVITY

Programming the Generation 4 CommandCenter for perfect night work lighting couldn't be easier.

Working after dark is nothing new to you. But now you can see your fields in a whole new light. Our factory-installed lighting packages cast the best light to work by all around your 6R Series. Or make working the night shift more productive than ever with our LED lighting packages. They consume less power, deliver brighter, daylight quality light and go the distance.



SELECT LIGHT PACKAGE

- 1 | Six front grille-mounted halogen lights
- 2 | Eight cab roof mounted halogen lights
- 3 | Two beltline mounted turn lights
- 4 | Two fender mounted brake and turn lights

PREMIUM LIGHT PACKAGE

- 1 | Six front grille-mounted halogen lights
- 2 | Twelve cab roof mounted halogen lights (ten if combined with panorama roof selected)
- 3 | Two beltline mounted turn lights
- 4 | Two fender mounted brake and turn lights
- 5 | Two fender mounted halogen lights
- 6 | Footsteps lights on both sides

ULTIMATE LIGHT PACKAGE

Same number of lights as in premium package. Hallogen lights replaced by LED (except for 2 low beam road lights).

OPTIONAL

- 7 | Two belt line work lights (Halogen or LED)
- 8 | Two Belt line road lights (H4)
- 9 | Single or dual beacon

Work lights are cleverly integrated into the front, rear and sides of the roofline to prevent damage from low branches.



GET HITCHED TO PRODUCTIVITY

Now you can combine pulling power with versatility across a broad variety of applications. 6R tractors offer a wide range of hitch, PTO and drawbar options, with all hitch parameters easily controlled from the CommandCenter.

REAR PTO CHOICES

An independent 3-speed electrically shifted rear PTO is standard on all 6R tractors – options include 540/1000/1000E and 540/540E/1000.



POWERFUL HITCH OPTIONS

For full pulling power, 6R tractors offer three different rear hitch options. A category 2/3N with lift capacity of up to 6,800 kg. A category 3 for lifts of up to 9,550 kg, and a category 3N for up to 10,400 kg.



Automatic and mechanical wagon hitch with 38 mm ball-pin

Piton fix hitch

Ball-type hitch

Forced Steering System

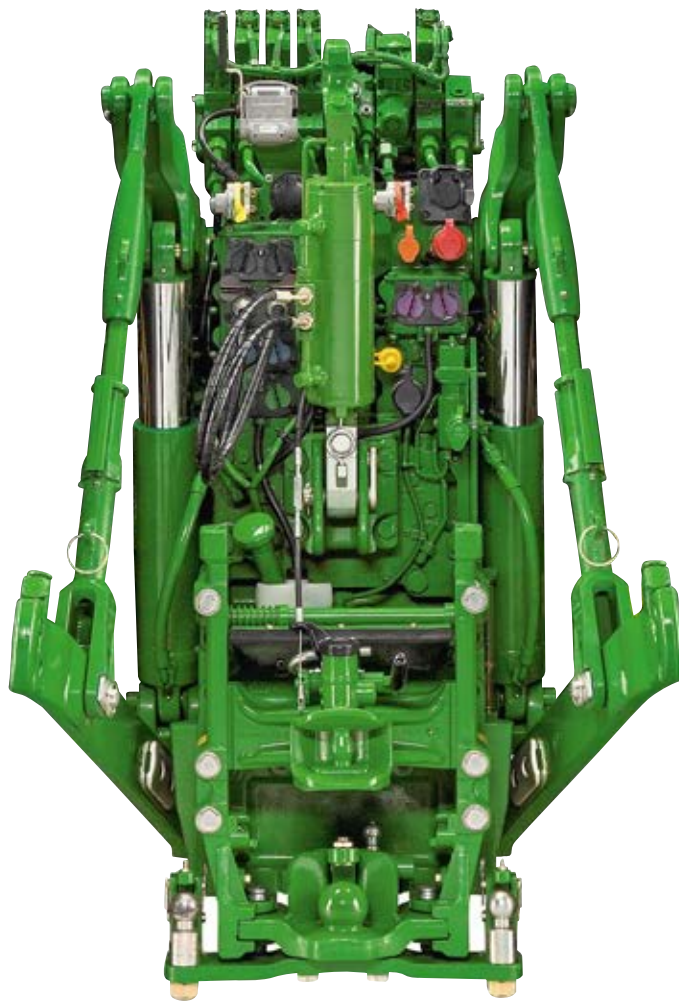

AUTOMATIC WAGON HITCH

Makes attaching implements much more convenient compared to manual wagon hitches.

BALL-TYPE AND PITON FIX HITCHES

Fulfilling all customer requirements, these hitches provide optimum traction and driving dynamics for tractor/trailer combinations.

FORCED STEERING SYSTEM

For even higher versatility our hitches can also be equipped with a forced steering system to operate large trailers with steering axles (attachment only).



BIG FRONT HITCH LIFT

Also available: a fully integrated front hitch with up to 5,000 kg maximum lift capacity. Plus, the 6R can also be ordered with an iTEC capable front PTO.

STRONG FLOW, EASY CONTROL

There's plenty of power to go around with the closed-centre, pressure and flow-compensated hydraulic system.

POWER BEYOND

Power Beyond auxiliary hydraulic connections provide live hydraulic power to equipment. This enables the supply of hydraulic oil to implements with their own control valves or hydraulic motors (for example, on large air seeders or on planters). The system includes one motor return coupler, one flat-face sump coupler, one Power Beyond pressure coupler and one load sense coupler.



SCV'S

In a 6R you get up to six electro-hydraulic selective control valves (SCVs) – with pressure relief lever, logically clustered, and all iTEC capable. You can easily control flow rates and times from the cab with the CommandCenter.





FRONT SCV'S

For your hydraulic power requirements at the front, the front hitch can be ordered with up to two iTEC capable SCVs.

HYDRAULIC PUMPS

Definitely located at the upper end of the performance spectrum, the hydraulic pump of the 6230R and 6250R delivers an impressive flow of 160 l/min at only 1,500 RPM. All other models still produce a strong 114 l/min flow, and an optional 155 l/min pump is also available.

| | 80 L/MIN | 114 L/MIN | 155 L/MIN | 160 L/MIN (@1,500 RPM) |
|-------------|----------|-----------|-----------|------------------------|
| 6110R-6135R | ■ | □ | - | - |
| 6145R-6215R | - | ■ | □ | - |
| 6230R-6250R | - | - | - | ■ |

■ base □ optional - not available

RAISE YOUR GAME

The perfect match. Tractor, loader and implements, all designed for each other – for unrestrained performance and peerless ease of use.

Easy to mount, quick to take off – it's the essence of productivity. John Deere R Series front loaders have our automatic latch designs, making the installation of loader and implements as easy as click & go. Three self-levelling options guarantee perfectly balanced application of the 6R's substantial power to the task at hand. The John Deere levelling link design makes more power available for lifting and never gets in the way of the operator's view.



UNDERSLUNG LEVELLING LINK

The geometry of our front loader linkage has several advantages. The under-slung levelling link does not impair your view, conveys more power and provides easier access for servicing.



CLICK AND GO

Mounting our front loaders could not be quicker, safer or more convenient thanks to the self-correcting floating system of the built-in automatic mast latch. Separation is just as easy.



AUTOMATIC IMPLEMENT LATCH

With this option, the implement is self-guided by centre guides and is automatically latched as soon as it reaches the carrier frame. Unlatching is convenient with a cab mounted switch but can also be done manually. It's a straightforward system that uses a gas accumulator/oil pressure combination to lock and unlock.

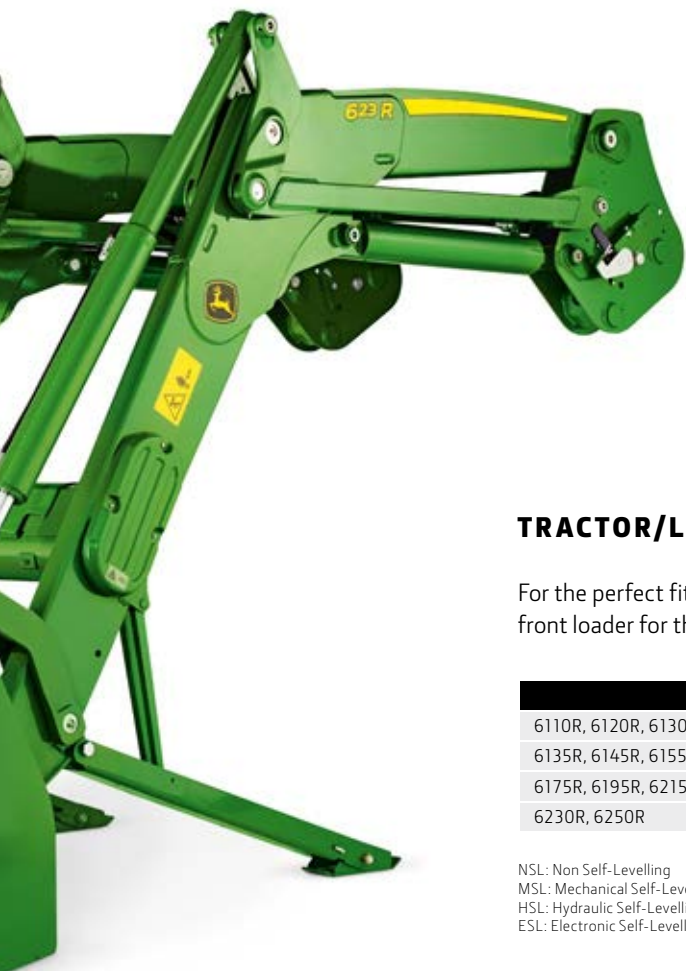

TRACTOR/LOADER COMPATIBILITY

For the perfect fit, you have a choice of two front loader sizes for 6110R-6215R models and one front loader for the 6230R and 6250R models.

| | 623R (NSL, MSL, HSL) | 643R (NSL, MSL, HSL) | 663R (NSL, MSL, ESL) | 683R (MSL, ESL) |
|---------------------|----------------------|----------------------|----------------------|-----------------|
| 6110R, 6120R, 6130R | ■ | ■ | - | - |
| 6135R, 6145R, 6155R | - | ■ | ■ | - |
| 6175R, 6195R, 6215R | - | - | ■ | ■ |
| 6230R, 6250R | - | - | - | ■ |

NSL: Non Self-Levelling
 MSL: Mechanical Self-Levelling
 HSL: Hydraulic Self-Levelling
 ESL: Electronic Self-Levelling

ELECTRONIC RECONFIGURABLE JOYSTICK

Easily the most comfortable way to operate a front loader, the joystick offers up to five reconfigurable functions, including loader suspension, GSS and diverter valves.

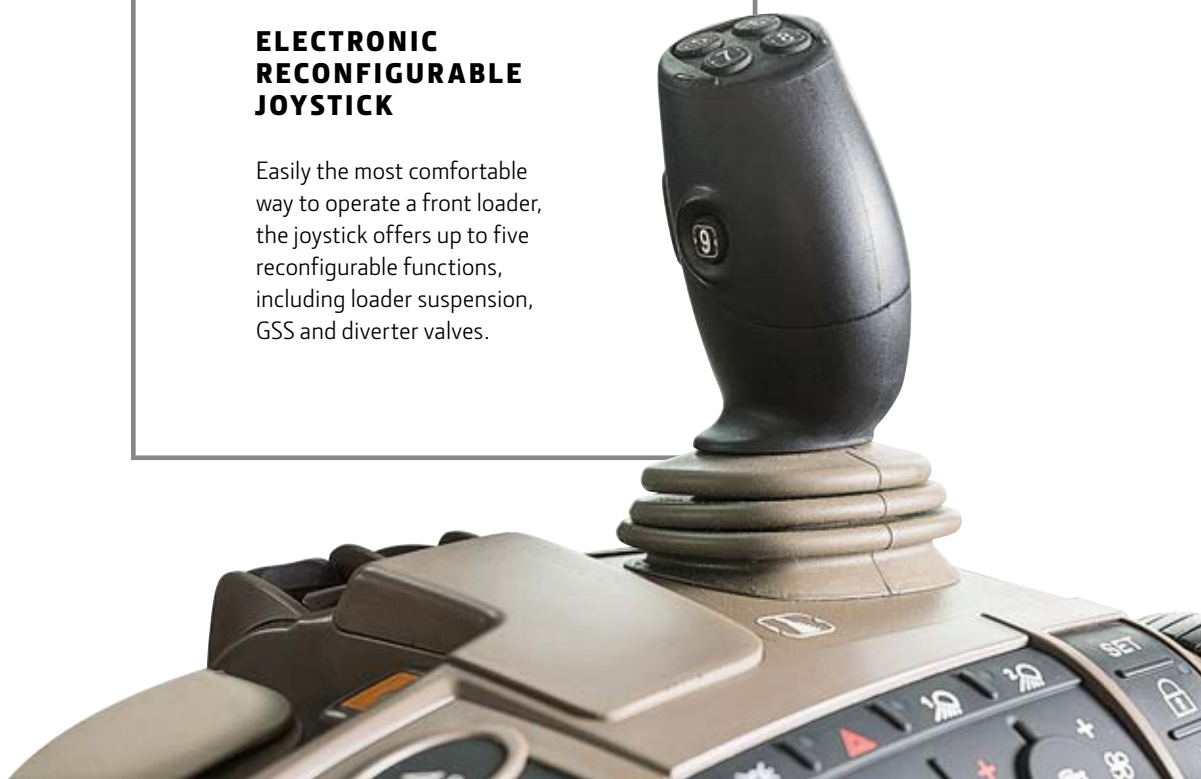

BOOSTING PRODUCTIVITY AND EASE OF OPERATION



There's a range of optional solutions that help you access all the built-in benefits of your John Deere front loader. They save valuable time, boost convenience and reduce operator fatigue.



ELECTRONIC SELF-LEVELLING (ESL)

Implement self-levelling and RTP* functionality regardless of which implement is connected, thanks to 2 sensors in the boom. Easily set it up with the loader joystick and CommandCenter screen.

LEVEL-TO-HORIZON

No need to ever again level implements manually. The convenient Level-to-horizon feature keeps your loader implement in a horizontal position, regardless of the slope your tractor is on.



Combi Euro/
MX Carrier



Combi Euro/SMS Carrier

CARRIER CHOICES

The ex-factory Standard Euro Carrier of your front loader fits all your Euro implements. The Combi Euro/SMS Carrier adds SMS implements. And our Combi Euro/MX Carrier is all that's required to work in the Euro or MX configuration. Reconfiguration can be performed manually, without tools in one minute.



NEW 4-POINT RETURN TO POSITION (RTP)*

Automatically returns your loader and implement to any of 4 pre-set heights and angles. RTP works in conjunction with ESL, for high operational accuracy no matter which implement is connected.



LOADER SUSPENSION

Effective damping provides a smoother ride for load, tractor and operator. It's activated with the joystick suspension button (M-LCV tractors) or the electronic joystick (E-LCV tractors).



LOADER LIGHTS

Purpose-built John Deere loader lights provide the consistent and reliable illumination you need when working with a front loader in darkness or poor visibility. Our lamps fit perfectly and also offer exceptional value.

MAKE THE MOST OF YOUR DAY

AUTOTRAC

AutoTrac hands-free steering adds more comfort: It reliably steers your tractor from day to night, through dust or on hilly terrain. This prevents costly overlaps or gaps and enables every operator to run at peak performance. With the Generation 4 CommandCenter and a StarFire receiver, all you need is a CommandCenter AutoTrac activation and you're ready to start. Using AutoTrac you can expect up to 8* percent input savings and up to 14** percent productivity increase.

THE NEW STARFIRE 6000 RECEIVER

Fascinating with yet a new level of accuracy, signal stability and repeatability:

RTK WITH 2.5 CM

Pass-to-pass accuracy, featuring long-term repeatability including 14 days RTK Extend if you lose line of sight or mobile network.

SF3 ENABLING 3 CM

Pass-to-pass accuracy and 9-month in-season-repeatability.

IMPROVED SF1 WITH 15 CM

Pass-to-pass accuracy, free of charge.

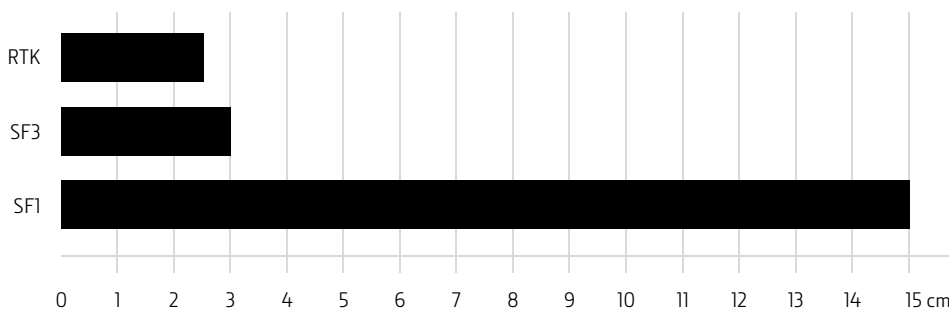

*From 'Lohnunternehmen' 1/2010
 **From 'Landtechnik' 6/2006



NEW PRECISION

The John Deere Mobile RTK Signal can be operated via JDLink. Saving you the extra cost of an RTK Modem and the annual cost of a SIM-card with data plan. (Check country availability).

PERFECT RESULTS

ADVANCED GUIDANCE AND PRECISION FARMING SOLUTIONS

Take the next step in precision farming with AutoTrac Turn Automation and Section Control.



AUTOTRAC TURN AUTOMATION

Sit back and relax, while you enjoy picture perfect headlands and consistent crop growth. AutoTrac Turn Automation automatically controls steering on headlands as well as tractor and implement functions like speed, hitch, hydraulics, PTO, four-wheel drive engagement.

JOHN DEERE SECTION CONTROL

John Deere Section Control minimises skips and overlaps automatically on-the-go. As a result, you can do a better job faster – and save money on fertiliser, chemicals and seed. This ISOBUS standard solution is available for sprayers, seeders/planters and spreaders.





JOHN DEERE MANURE SENSING

NUTRIENTS FOR YOUR BUSINESS

Manure is a high quality but extremely heterogeneous fertiliser. Nutrient levels vary significantly up to factor 25 – even within one tank load. John Deere Manure Sensing enables on-the-go analysis of nutrients in manure and thereby close to the applicator. An NIR (Near Infrared) sensor fitted to the slurry tanker measures N, P, K, NH₄ and dry matter with more than 4,000 measurements per second. With a John Deere tractor, the sensor can directly command speed and flow rate adjustments to increase or lower application rates based on your desired nutrient target level and even leveraging a prescription map. This enables you to maximise yields and meet legal requirements while cutting costs on mineral fertiliser.

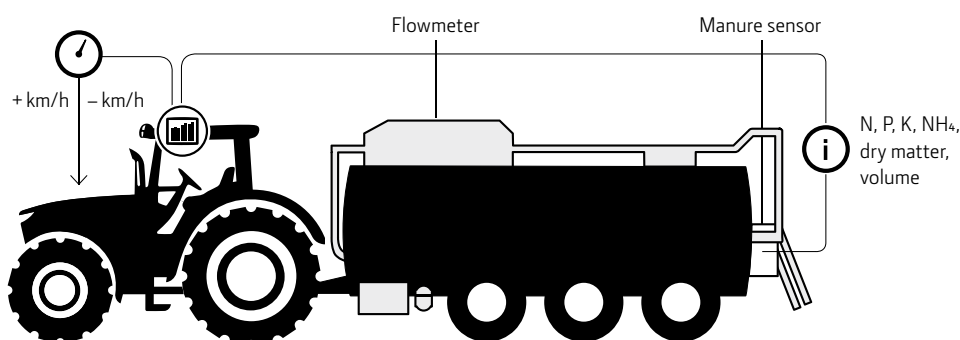

SITE-SPECIFIC APPLICATION

Target rate based on kg/ha N, P, K, NH₄ or volume. Limit rate for second ingredient.

TRACTOR-IMPLEMENT AUTOMATION

Automatic speed adjustment with John Deere tractors. Manual speed adjustment with non-John Deere tractors.

SITE SPECIFIC DOCUMENTATION

Applied volume. Applied amount of nutrients.

EASY ACCESS TO COLLECTED DATA

Nutrient maps accessible in the Operations Center on MyJohnDeere.com

CONNECTED FARM MANAGEMENT

You're managing a complex enterprise. That's why optimising the overall business depends on being well connected to your ongoing operations.

The Operations Center on our ag web portal MyJohnDeere.com makes it simple. It connects you to your machines, your operators and your fields from one central location. It also allows you to exchange information seamlessly with your John Deere dealer, your contractor or other trusted partners.

WORK SMARTER. NOT HARDER.

The combination of AutoTrac and the John Deere Operations Center allows you to prepare all your field boundaries, guidance lines and implement offsets during off-peak season and send them to your machines with a simple click. As field work is completed, documentation data is automatically uploaded from your in-cab display to your personal Operations Center account. This saves valuable time in peak season and improves efficiency.



JDLink is the key to your tractor's connectivity – linking together you, your machine and your office.



AUTOTRAC. NOW CONNECTED.

Together, AutoTrac and the John Deere Operations Center connect your office and your machines to improve overall business efficiency.



CONNECTED SUPPORT

A machine connected with JDLink helps your dealer to connect with your in-cab display and remotely assist you with machine setup and operation leveraging Remote Display Access. Service Advisor Remote enables your dealer to install the latest software updates, read out diagnostic trouble codes on demand or perform various recordings to support initial error diagnosis much quicker and more cost-effectively than with in-field visits. Based on software algorithms, Expert Alerts will help service technicians to predict certain upcoming issues before they arise, so that they can react quickly and increase uptime significantly.

Ideally, you should be connected with a FarmSight Service agreement to train and support you with the use of these technologies.



JOB MANAGEMENT MADE EASY

Eliminate paperwork and phone calls during job planning, execution and reporting. With MyJobConnect you can assign tasks to your operators in real-time utilising the MyJobsManager App – and it's all documented for quick reporting and invoicing when the job is done.

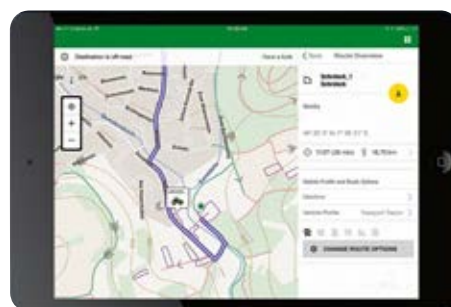

INTELLIGENT AG NAVIGATION & FLEET LOGISTICS

Maximum efficiency for multi-machine operations: MyJobConnect Premium extends MyJobConnect to a true mixed fleet logistics solution featuring fleet overview, turn-by-turn navigation, a comprehensive field road database and estimated arrival times for vehicles.

EXPERIENCE THE POWERGARD FEELING

When it comes to protecting your machines and your business, peace of mind is not something that somehow happens if you're lucky. Peace of mind is a choice that you can make.

PowerGard agreements protect you against unexpected repair costs and keep your maintenance on track with genuine parts. Three fixed rate packages provide increasingly comprehensive levels of cover to keep your machine running at peak performance with steady uptime.



FINANCING

Our goal is simple: Empower you to purchase what you need to take your business to the next level. This includes financing your PowerGard Protection agreements at competitive rates, with flexible payments.*

POWERGARD MAINTENANCE

Preventative maintenance work – it's essential for keeping equipment in good working order based on factory recommended intervals.

POWERGARD PROTECTION

Base level of protection that covers unusual events that can lead to costly repairs, and also covers the main drive train components.

POWERGARD PROTECTION PLUS

The ultimate in protection – the total peace of mind package that covers all components included in PowerGard Protection, plus electrical, cooling, hydraulics and more.

*Financing for PowerGard Maintenance is currently only available with participating dealers. Country regulations apply.



FARMSIGHT SERVICES UPTIME DELIVERED

You rely on your tractor every second during season. You should, and you can – with FarmSight Service packages. We're committed to keep you working without compromise. We continuously invest in technician training and the latest technology to support you in the most efficient manner. Our FarmSight Service packages have been designed with two goals in mind: maximise your uptime and minimise your cost of operation. See for yourself – unlock the full potential of your John Deere tractor.

***“PROFIT FROM
EFFICIENCY GAINS AND
ADDITIONAL UPTIME
HOURS FROM DAY ONE.”***

FARMSIGHT SERVICES EXPERT



YOUR WORKPLACE, YOUR CHOICE

It's where you work, so make it yours by choosing our Select, Premium or Ultimate editions. In addition to that, we offer two connectivity packages for all 6R tractors.



SELECT

All the basics: right-hand console with 4200 CommandCenter for intuitive control of tractor functions and 3 SCVs – plus convenient automatic gear shifting with AutoQuad



PREMIUM

More comfort: The CommandARM with 4200 CommandCenter, 3 electrical SCVs and our iTEC headland management system (HMS). Choose between our two top-of-the-line transmissions: DirectDrive or AutoPowr



ULTIMATE

AutoPowr transmission with CommandPRO, 4600 CommandCenter and a long list of options offering additional comfort and performance

EDITIONS

| DESCRIPTION | SELECT | PREMIUM | ULTIMATE |
|---|--------|---------|----------|
| TLS FRONT AXLE SUSPENSION IS IN BASE OF EVERY 6R | | | |
| TRANSMISSION | | | |
| AutoQuad transmission | ■ | – | – |
| DirectDrive transmission | – | ■ | – |
| AutoPowr transmission (in base for 6230R and 6250R) | – | ■/□ | ■ |
| CAB | | | |
| Standard seat | ■ | – | – |
| Premium seat | □ | ■ | ■ |
| Ultimate seat | – | □ | □ |
| Cab Suspension | □ | □ | ■ |
| CommandARM | – | ■ | ■ |
| CommandPRO | – | □ | ■ |
| 4200 CommandCenter | ■ | ■ | – |
| 4600 CommandCenter | – | □ | ■ |
| Select Light package | ■ | – | – |
| Premium Light Package | □ | ■ | – |
| Ultimate Light Package | – | □ | ■ |
| iTEC headland management system | □ | ■ | ■ |
| Wide angle mirrors manual | ■ | – | – |
| Wide angle mirrors electric | – | ■ | ■ |
| Cooling compartment | □ | □ | ■ |
| Climate control | □ | □ | ■ |
| Standard – radio | ■ | ■ | – |
| Premium – radio | □ | □ | ■ |
| ISOBUS Ready (in base for 6145R-6250R) | □/■ | ■ | ■ |
| HYDRAULICS | | | |
| Hydraulic pump 114 l/min | ■ | ■ | –/■ |
| Hydraulic pump 155 l/min (available for 6145R - 6215R, in base for 6230R and 6250R) | – | □ | ■ |
| 3 mechanical SCVs – Premium | ■ | – | – |
| 3 electrical SCVs – Premium | □ | ■ | ■ |
| 4 to 6 electrical SCVs – Premium | □ | □ | □ |
| Fender controls for 3rd electrical SCV | □ | □ | ■ |
| Power Beyond preparation (rear) | □ | □ | ■ |
| Lift link adjustment LH & RH mid/small | ■ | ■ | ■ |
| Additional oil reservoir | ■ | ■ | ■ |

Legend: ■ base for editions; □ optional for editions; – excluded for editions

Editions can be modified by John Deere without previous notification. Please check with your John Deere dealer for the latest editions.

CONNECTIVITY PACKAGES

| CONNECTIVITY PACKAGE ULTIMATE | PREMIUM | ULTIMATE |
|---|---------|----------|
| Auto Trac Ready (in base for 6230R and 6250R) | ■ | ■ |
| 4600 CommandCenter | ■ | ■ |
| 4600 CommandCenter with Extended Monitor | – | ■ |
| Gen 4 CommandCenter Premium Activation | ■ | – |
| Gen 4 CommandCenter Ultimate Activation | – | ■ |
| Tractor Implement Automation | ■ | ■ |
| JDLINK hardware (subscription not included) | ■ | ■ |
| JDLINK Connect 1 Year/Access 5 Years promotional subscription | ■ | ■ |
| MyJobConnect or MyJobConnect Premium (only available in DE, UK, FR, NL, DK) | □ | ■ |

Legend: ■ base; □ optional; – excluded

Elements of the Connectivity Packages are a limited promotional offer and include time based subscriptions. Be aware that some of the Connectivity Package as well as elements could not be available in all regions. Please contact your local John Deere dealer for availability.

SPECIFICATIONS 6R SMALL AND MID FRAME MODELS

| MODEL | 6110R | 6120R | 6130R | 6135R | 6145R | 6155R |
|---|--|-------------|-------------|---------------|---|-------------|
| ENGINE PERFORMANCE | | | | | | |
| Rated power (ECE-R120), hp (kW) | 110 (81) | 120 (88) | 130 (96) | 135 (99) | 145 (107) | 155 (114) |
| Rated power with IPM (ECE-R120) @ 2,100 1/min, hp (kW) | 130 (96) | 140 (103) | 150 (110) | 165 (122) | 185 (136) | 195 (144) |
| Max. power (ECE-R120), hp (kW) | 121 (89) | 132 (97) | 143 (105) | 146 (109) | 160 (117) | 171 (125) |
| Constant power range, rpm | 2,100-1,550 | 2,100-1,550 | 2,100-1,550 | 2,100-1,550 | 2,100-1,550 | 2,100-1,550 |
| Torque reserve, % percentage | 40 | 40 | 40 | 40 | 40 | 40 |
| Maximum torque, Nm (at 1,600 engine rpm) | 515 | 562 | 609 | 632 | 677 | 724 |
| Rated speed, rpm | 2,100 | | | | | |
| Manufacturer | John Deere Power Systems | | | | | |
| Type | PowerTech PSS | | | PowerTech PVS | | |
| Aftertreatment | Lifetime Diesel Particulate Filter (DPF), Diesel Oxidation Catalyst (DOC) and Selective Catalytic Reduction (SCR) using DEF | | | | | |
| Engine air filter | PowerCore® G2 air filter with pre-cleaning | | | | | |
| Aspiration | Dual turbochargers, variable geometry turbo with fixed geometry turbo in series | | | | Variable geometry turbocharger | |
| Cylinders/Displacement | 4/4.5 l | | | | 6/6.8 l | |
| Cooling system | Distributed cooling system with temperature controlled viscous fan drive and dedicated fan for charge air cooler | | | | | |
| Fuel injection system & control | High pressure common rail system with up to 2,000 bar injection pressure, electronically controlled | | | | High pressure common rail system with up to 2,500 bar injection pressure, electronically controlled | |
| TRANSMISSIONS | | | | | | |
| POWRQUAD PLUS | | | | | | |
| 20/20 2.5 - 40 km/h | - | - | - | - | ■ | ■ |
| 24/24 1.4 - 40 km/h | ■ | ■ | ■ | ■ | | |
| AUTOQUAD PLUS | | | | | | |
| 20/20 2.5 - 40 km/h | - | - | - | - | ■ | ■ |
| 24/24 1.4 - 40 km/h | ■ | ■ | ■ | ■ | | |
| 20/20 2.5 - 50 km/h | - | - | - | - | ■ | ■ |
| 24/24 1.9 - 50 km/h | ■ | ■ | ■ | ■ | - | - |
| AUTOQUAD PLUS ECOSHIFT | | | | | | |
| 20/20 2.5 - 40 km/h | - | - | - | - | ■ | ■ |
| 24/24 1.9 - 40 km/h | ■ | ■ | ■ | ■ | - | - |
| AUTOPOWR | | | | | | |
| 0.05 - 40 km/h | ■ | ■ | ■ | ■ | ■ | ■ |
| 0.05 - 50 km/h | ■ | ■ | ■ | ■ | ■ | ■ |
| DIRECTDRIVE | | | | | | |
| 2.7 - 40 km/h | - | - | - | - | ■ | ■ |
| 2.7 - 50 km/h | - | - | - | - | ■ | ■ |
| Creeper (PowrQuad Plus, AutoQuad Plus and AutoQuad Plus Ecoshift) | ■ | ■ | ■ | ■ | ■ | ■ |
| AXLES | | | | | | |
| Suspended front axle (option) | Triple Link Suspension (TLS Plus) MFWD Axle, hydro-pneumatic, permanently active, triple link, self-levelling, load adjusting suspension | | | | | |
| Suspension range with TLS Plus | 100 mm suspension range | | | | | |
| Engagement front differential lock | Self-locking differential | | | | | |
| Engagement rear differential lock | Electro-hydraulic with oil cooled clutch | | | | | |
| Rear axle | Flange axle | | | | | |
| STEERING | | | | | | |
| Type | Dynamic load sensing, hydrostatic, flow metering; Variable Ratio Steering optional | | | | | |
| HYDRAULIC SYSTEM | | | | | | |
| Type | Pressure & Flow Compensated (PFC) system with load sensing function | | | | | |
| Flow at rated engine speed base/option, l/min | 80/114 | | | | 114/155 | |
| Selective control valves | Up to 5+3 | | | | Up to 6+3 | |
| Power beyond | Optional | | | | | |
| Oil take out capacity with overfill, l | 25 | | | | 39 | |
| Oil take out capacity with additional oil reservoir, l | 32 | | 37 | | 45 | |

| MODEL | 6110R | 6120R | 6130R | 6135R | 6145R | 6155R |
|---|---|-----------------|-----------------|-----------------------|-------------------|-----------------|
| 3-POINT HITCH – REAR | | | | | | |
| Type | Electronic lower link sensing; load & depth control, infinite mix, float | | | | | |
| Category | II/IIIN | IIIN | | | III | |
| Maximum lift capacity at hooks, kg | 5,300 | 5,300 | 6,000 | 6,800 | 8,100 | 8,100 |
| Lift capacity through full lift range (OECD 610 mm), kg | 3,350 | 3,350 | 3,850 | 4,350 | 4,200 | 4,200 |
| Lift capacity through full lift range (OECD 1,800 mm), kg | 2,050 | 2,050 | 2,350 | 2,660 | 3,200 | 3,200 |
| 3-POINT HITCH – FRONT, OPTIONAL | | | | | | |
| Type | Front hitch controlled by rear SCV (Economy option) or dedicated SCV (Premium option) | | | | | |
| Category | IIIN | | | | | |
| Maximum lift capacity at hooks, kg | 4,000 | | | | | |
| Lift capacity through full lift range (OECD at the hooks), kg | 3,300 | | | | | |
| REAR PTO | | | | | | |
| Type | Electro-hydraulically engaged, oil cooled, multi-disc design | | | | | |
| Engine rpm at rated PTO speeds with 540/540E/1000 option | 1,967/1,496/1,962 | | | | 1,987/1,753/2,000 | |
| Engine rpm at rated PTO speeds with 540E/1000/1000E option | – | | | | | |
| FRONT PTO, OPTIONAL | | | | | | |
| Type | Electro-hydraulically engaged, oil cooled | | | | | |
| Engine speed at rated PTO speed (1,000), rpm | 1,969 | | | | | |
| CAB | | | | | | |
| Specifications | ComfortView cab with 2 panorama doors and Generation 4 CommandCenter Display | | | | | |
| Suspension (option) | Adaptive hydraulic cab suspension HCS Plus | | | | | |
| Noise level at operator's ear, dB(A) | 71 | | | | | |
| Cab glass area, m ² | 6.11 | | | | | |
| Cab volume, m ³ | 3.33 | | | | | |
| Display | Generation 4 CommandCenter 4200 8.4" or 4600 10" Display | | | | | |
| MISCELLANEOUS | | | | | | |
| AutoTrac Ready | Optional | | | | | |
| ISOBUS ready | Optional | | | | | |
| CommandCenter video inputs | 1 input for 4200 8.4" Display, 4 inputs for 4600 10" Display | | | | | |
| Immobilizer | Optional | | | | | |
| Drive pedal mode | AutoPowr only | | | | | |
| Trailer brake systems (options) | Hydraulic and/or pneumatic system | | | | | |
| Pneumatic trailer brake system (option) | Electro-magnetic compressor clutch, hydraulic retarding valve, air drier included | | | | | |
| CAPACITIES | | | | | | |
| Fuel tank (base/option), l | 225/195 | | 305/265 | | 312/270 | |
| Engine coolant, l | 22 | | 27 | | | |
| DIMENSIONS AND WEIGHTS | | | | | | |
| Wheelbase, mm | 2,580 | | | 2,765 | | |
| Width x Height x Length, mm | 2,430 x 2,890 x 4,540 | | | 2,490 x 2,950 x 4,930 | | |
| <i>Measured with flanged axle, up to cab roof, from front weight support to horizontal draft link hooks and with max. front tyres/max. rear tyre sizes.</i> | | | | | | |
| Ground clearance, mm | 481 | 481 | 481 | 528 | 553 | 553 |
| <i>Measured at center of front axle, using max. front and max. rear tyre sizes</i> | | | | | | |
| Shipping weight, kg | 6,000 | 6,100 | 6,200 | 6,400 | 6,900 | 7,100 |
| <i>Measured with average specifications</i> | | | | | | |
| Maximum permissible gross weight, kg | 8,950 | 9,950 | 9,950 | 10,450 | 11,250 | 11,750 |
| TYRE SIZES | | | | | | |
| Front tyre sizes, max. available (diameter in cm) | 540/65R24 (134) | 540/65R24 (134) | 540/65R24 (134) | 540/65R28 (144) | 600/65R28 (152) | 600/65R28 (152) |
| Rear tyre sizes, max. available (diameter in cm) | 600/65R38 (178) | 600/65R38 (178) | 600/65R38 (178) | 650/65R38 (185) | 710/70R38 (200) | 710/70R38 (200) |

SPECIFICATIONS 6R LARGE FRAME MODELS

| MODEL | 6175R | 6195R | 6215R | 6230R | 6250R |
|--|--|-----------|-----------|---|-----------|
| ENGINE PERFORMANCE | | | | | |
| Rated power (ECE-R120), hp (kW) | 175 (129) | 195 (143) | 215 (158) | 230 (169) | 250 (184) |
| Rated power with IPM (ECE-R120) @ 2,100 1/min, hp (kW) | 215 (158) | 235 (173) | 255 (188) | 270 (199) | 290 (213) |
| Rated power with IPM (ECE-120R) @ 1,900 1/min | – | – | – | 280 (206) | 300 (221) |
| Max. power (ECE-R120) hp (kW) | 193 (142) | 215 (158) | 237 (174) | 253 (186) | 275 (202) |
| Constant power range, rpm | 2,100-1,600 | | | | |
| Torque reserve, % percentage | 40 | | | | |
| Maximum torque, Nm (at 1,600 engine rpm) – without boost | 817 | 910 | 1,004 | 1,074 | 1,167 |
| Rated speed, rpm | 2,100 | | | | |
| Manufacturer | John Deere Power Systems | | | | |
| Type | PowerTech PVS | | | PowerTech PSS | |
| Aftertreatment | Lifetime Diesel Particulate Filter (DPF), Diesel Oxidation Catalyst (DOC) and Selective Catalytic Reduction (SCR) using DEF | | | | |
| Engine air filter | PowerCore® G2 air filter with pre-cleaning | | | External A-Post Filter with pre-cleaning | |
| Aspiration | Variable geometry turbocharger | | | Dual turbochargers, variable geometry turbo with fixed geometry turbo in series | |
| Cylinders/Displacement | 6/6.8 l | | | | |
| Cooling system | Distributed cooling system with temperature controlled viscous fan drive and dedicated fan for charge air cooler | | | Distributed cooling system with temperature controlled electric fan drive and dedicated fan for charge air cooler | |
| Fuel injection system & control | High pressure common rail system with up to 2,500 bar injection pressure, electronically controlled | | | | |
| TRANSMISSIONS | | | | | |
| POWRQUAD PLUS | | | | | |
| 20/20 2.5 - 40 km/h | ■ | ■ | ■ | – | – |
| AUTOQUAD PLUS | | | | | |
| 20/20 2.5 - 40 km/h | ■ | ■ | ■ | – | – |
| 20/20 2.5 - 50 km/h | ■ | ■ | ■ | – | – |
| AUTOQUAD PLUS ECOSHIFT | | | | | |
| 20/20 2.5 - 40 km/h | ■ | ■ | ■ | – | – |
| AUTOPOWR | | | | | |
| 0.05 - 40 km/h | ■ | ■ | ■ | ■ | ■ |
| 0.05 - 50 km/h | ■ | ■ | ■ | ■ | ■ |
| DIRECTDRIVE | | | | | |
| 2.7 - 40 km/h | ■ | ■ | ■ | – | – |
| 2.7 - 50 km/h | ■ | ■ | ■ | – | – |
| AXLES | | | | | |
| Suspended front axle | Triple Link Suspension (TLS Plus) MFWD Axle in base; hydro-pneumatic, permanently active, triple link, self-levelling, load adjusting suspension | | | Braked Triple Link Suspension (TLS Plus) MFWD Axle in base; hydro-pneumatic, permanently active, triple link, self-levelling, load adjusting suspension | |
| Suspension range with TLS Plus | 100 mm suspension range | | | | |
| Engagement front differential lock | Self-locking differential; 100% differential lock optional | | | 100% differential lock in base | |
| Engagement rear differential lock | Electro-hydraulic with oil cooled clutch | | | | |
| Rear axle | Flange axle or rack & pinion axle | | | | |
| STEERING | | | | | |
| Type | Dynamic load sensing, hydrostatic, flow metering; Variable Ratio Steering optional | | | | |
| HYDRAULIC SYSTEM | | | | | |
| Type | Pressure & Flow Compensated (PFC) system with load sensing function | | | | |
| Flow at rated engine speed base/option, l/min | 114/155 | | | 160 (max. flow available at 1,500 rpm) | |
| Selective control valves | Up to 6+3 | | | | |
| Power beyond | Optional | | | | |
| Oil take out capacity with overfill, l | 42 | | | – | |
| Oil take out capacity with additional oil reservoir, l | 55 | | | 80 | |

| MODEL | 6175R | 6195R | 6215R | 6230R | 6250R |
|---|--|--------|--------|---|-------|
| 3-POINT HITCH – REAR | | | | | |
| Type | Electronic lower link sensing; load & depth control, infinite mix, float | | | | |
| Category | III | | | IIIN | |
| Maximum lift capacity at hooks, kg | 8,500 | 8,500 | 9,550 | 10,400 | |
| Lift capacity through full lift range (OECD 610 mm), kg | 4,850 | 4,850 | 5,450 | 7,000 | |
| Lift capacity through full lift range (OECD 1,800 mm), kg | 3,400 | 3,400 | 3,800 | 4,300 | |
| 3-POINT HITCH – FRONT | | | | | |
| Type | Front hitch controlled by rear SCV (Economy option) or dedicated SCV (Premium option) | | | Front hitch controlled by dedicated SCV in base | |
| Category | IIIN | | | | |
| Maximum lift capacity at hooks, kg | 4,000 | | | 5,000 | |
| Lift capacity through full lift range (OECD at the hooks), kg | 3,300 | | | 4,400 | |
| REAR PTO | | | | | |
| Type | Electro-hydraulically engaged, oil cooled, multi-disc design | | | | |
| Engine rpm at rated PTO speeds with 540/540E/1000 option | 1,950/1,721/1,950 | | | 1,950/1,721/1,950 | |
| Engine rpm at rated PTO speeds with 540E/1000/1000E option | 1,761/1,989/1,756 | | | 1,618/2,012/1,659 | |
| FRONT PTO, OPTIONAL | | | | | |
| Type | Electro-hydraulically engaged, oil cooled, 80 kW power | | | Electro-hydraulically engaged, oil cooled, 115 kW power | |
| Engine speed at rated PTO speed (1,000), rpm | 1,969 | | | | |
| CAB | | | | | |
| Specifications | ComfortView cab with 2 panorama doors or B-Post on left hand side and Generation 4 and CommandCenter Display | | | | |
| Suspension (option) | Adaptive hydraulic cab suspension HCS Plus | | | | |
| Noise level at operator's ear, dB(A) | 71 | | | 71 | |
| Cab glass area, m ² | 6.11 | | | | |
| Cab volume, m ³ | 3.33 | | | | |
| Display | Generation 4 CommandCenter 4200 7" or 4600 10" Display | | | | |
| MISCELLANEOUS | | | | | |
| AutoTrac Ready | Optional | | | Base | |
| ISOBUS ready | Base | | | Base | |
| CommandCenter video inputs | 1 input for 4200 8.4" Display, 4 inputs for 4600 10" Display | | | | |
| Immobiliser | Optional | | | | |
| Drive pedal mode | AutoPowr only | | | Base | |
| Trailer brake systems (options) | Hydraulic and/or pneumatic system | | | | |
| Pneumatic trailer brake system (option) | Electro-magnetic compressor clutch, hydraulic retarding valve, air drier included | | | | |
| CAPACITIES | | | | | |
| Fuel tank (base/option), l | 395/335 | | | 470/410 | |
| Engine coolant, l | 28 | | | 29 | |
| DIMENSIONS AND WEIGHTS | | | | | |
| Wheelbase, mm | 2,800 | | | 2,900 | |
| Width x Height x Length, mm | 2,550 x 3,160 x 5,050 | | | 2,550 x 3,250 x 5,190 | |
| <i>Measured with flanged axle, up to cab roof, from front weight support to horizontal draft link hooks and with max. front tyres/max. rear tyre sizes.</i> | | | | | |
| Height from centre of rear axle to top of cab (no beacon light), mm | 2,183 | | | 2,273 | |
| Turning radius, m | 5.62 | | | 6.32 | |
| <i>According to ISO789-3 measured for 600/65R30 at 2,050 mm tread setting and 1.6 bar inflation pressure on level ground</i> | | | | | |
| Shipping weight, kg | 8,300 | 8,400 | 8,500 | 9,300 | |
| <i>Measured with average specifications</i> | | | | | |
| Maximum permissible gross weight, kg | 12,700 | 13,450 | 13,450 | 15,000 | |
| TYRE SIZES | | | | | |
| Front tyre sizes, max. available (SRI) | 600/70 R30 (SRI 725) | | | 600/70R30 (SRI 750) | |
| Rear tyre sizes, max. available (SRI) | 800/70R38 (SRI 975) | | | | |

LOADER SPECIFICATIONS

| MODEL | | | 6110R/6120R/6130R | | 6110R/6120R/6130R | |
|---|----------------------------------|--------------|--------------------------|-------|--------------------------|-------|
| Front tyre | | | 480/70R24 | | 480/70R24 | |
| Rear tyre | | | 520/70R38 | | 520/70R38 | |
| Wheelbase | | (WB) in/mm | 101.6/2,580 | | 101.6/2,580 | |
| Pump capacity | | | 30/lpm | | 30/lpm | |
| Rated pressure | | | 2,900/200 | | 2,900/200 | |
| LOADER | | | 623R NSL | | 623R MSL | |
| Bucket | | | Standard Bucket 1,850 mm | | Standard Bucket 1,850 mm | |
| Bucket weight | | lb/kg | 520 | 236 | 520 | 236 |
| Lift capacity @ full height | Measured @ Pivot | (U) lb/kg | 5,781 | 2,622 | 5,265 | 2,388 |
| | Measured @ 500 mm ahead of Pivot | (V) lb/kg | – | – | – | – |
| | Measured @ 800 mm ahead of Pivot | (V) lb/kg | 3,874 | 1,757 | 5,009 | 2,272 |
| Lift capacity @ 59 in (1.5 m) lift height | Measured @ Pivot | (W) lb/kg | 6,016 | 2,729 | 6,023 | 2,732 |
| | Measured @ 500 mm ahead of Pivot | (X) lb/kg | – | – | – | – |
| | Measured @ 800 mm ahead of Pivot | (X) lb/kg | 4,632 | 2,101 | 5,692 | 2,582 |
| Boom breakout | Measured @ Pivot | (Y) lb/kg | 6,263 | 2,841 | 6,733 | 3,054 |
| | Measured @ 500 mm ahead of Pivot | (Z) lb/kg | – | – | – | – |
| | Measured @ 800 mm ahead of Pivot | (Z) lb/kg | 4,553 | 2,065 | 5,730 | 2,599 |
| Bucket rollback force | @ Maximum height | (VV) lb/kg | 4,978 | 2,258 | 5,137 | 2,330 |
| | @ 59 in (1.5 m) lift height | (XX) lb/kg | 9,367 | 4,249 | 9,407 | 4,267 |
| | @ Ground level | (ZZ) lb/kg | 9,608 | 4,358 | 9,570 | 4,341 |
| Maximum lift height | | (A) in/mm | 162 | 4,124 | 162 | 4,124 |
| Clearance | @ Full height – Bucket level | (B) in/mm | 152 | 3,854 | 152 | 3,854 |
| | @ Full height – Bucket dumped | (C) in/mm | 122 | 3,088 | 122 | 3,088 |
| Overall length | | (WB+F) in/mm | 202 | 5,128 | 202 | 5,128 |
| Digging depth | | (H) in/mm | -4 | -91 | -4 | -91 |
| Reach | @ Maximum height | (D) in/mm | 30 | 759 | 30 | 759 |
| | @ Ground – Bucket level | (F) in/mm | 100 | 2,548 | 100 | 2,548 |
| Bucket angles | Dump angle @ full height | (E) degrees | -59 | | -59 | |
| | Rollback @ ground | (G) degrees | 48 | | 48 | |
| | Dump angle @ ground | degrees | -151 | | -96 | |
| Cycle times | Loader raise | sec | 3.43 | | 3.37 | |
| | Loader lower | sec | 2.57 | | 2.53 | |
| | Bucket dump | sec | 2.65 | | 1.81 | |
| | Bucket rollback | sec | 1.81 | | 1.81 | |



The American Society of Agricultural and Biological Engineers is an educational and scientific organization dedicated to the advancement of engineering applicable to agricultural, food, and biological systems. Founded in 1907 and headquartered in St. Joseph, Michigan, ASABE comprises 8,000 members in more than 100 countries.

| 6110R/6120R/6130R | | 6110R/6120R/6130R | | 6135R | | 6135R | |
|---------------------|-------|---------------------|-------|---------------------|-------|---------------------|-------|
| 480/70R24 | | 480/70R24 | | 480/70R28 | | 480/70R28 | |
| 520/70R38 | | 520/70R38 | | 580/70R38 | | 580/70R38 | |
| 101.6/2,580 | | 101.6/2,580 | | 108.9/2,765 | | 108.9/2,765 | |
| 30/114 | | 30/114 | | 30/114 | | 30/114 | |
| 2,900/200 | | 2,900/200 | | 2,900/200 | | 2,900/200 | |
| 643R NSL | | 643R MSL | | 643R NSL | | 643R MSL | |
| Heavy duty 2,200 mm | | Heavy duty 2,200 mm | | Heavy duty 2,200 mm | | Heavy duty 2,200 mm | |
| 683 | 310 | 683 | 310 | 683 | 310 | 683 | 310 |
| 5,582 | 2,532 | 5,013 | 2,274 | 5,628 | 2,553 | 4,892 | 2,219 |
| - | - | - | - | - | - | - | - |
| 3,902 | 1,770 | 5,137 | 2,330 | 3,926 | 1,781 | 4,965 | 2,252 |
| 5,891 | 2,672 | 5,789 | 2,626 | 5,959 | 2,703 | 5,730 | 2,599 |
| - | - | - | - | - | - | - | - |
| 4,614 | 2,093 | 5,465 | 2,479 | 4,656 | 2,112 | 5,359 | 2,431 |
| 6,241 | 2,831 | 6,548 | 2,970 | 6,195 | 2,810 | 6,455 | 2,928 |
| - | - | - | - | - | - | - | - |
| 4,698 | 2,131 | 5,728 | 2,598 | 4,590 | 2,082 | 5,516 | 2,502 |
| 5,247 | 2,380 | 5,512 | 2,500 | 5,227 | 2,371 | 5,688 | 2,580 |
| 9,328 | 4,231 | 9,566 | 4,339 | 9,489 | 4,304 | 9,583 | 4,347 |
| 9,740 | 4,418 | 9,656 | 4,380 | 9,623 | 4,365 | 9,502 | 4,310 |
| 163 | 4,151 | 163 | 4,151 | 172 | 4,358 | 172 | 4,358 |
| 153 | 3,881 | 153 | 3,881 | 161 | 4,088 | 161 | 4,088 |
| 123 | 3,136 | 122 | 3,111 | 132 | 3,344 | 131 | 3,322 |
| 214 | 5,424 | 214 | 5,424 | 215 | 5,458 | 215 | 5,458 |
| -3 | -84 | -3 | -86 | -3 | -82 | -3 | -82 |
| 39 | 982 | 39 | 982 | 32 | 806 | 32 | 806 |
| 112 | 2,844 | 112 | 2,844 | 106 | 2,693 | 106 | 2,693 |
| -56 | | -60 | | -55 | | -59 | |
| 48 | | 48 | | 47 | | 47 | |
| -140 | | -119 | | -145 | | -116 | |
| 3.50 | | 3.31 | | 3.70 | | 3.52 | |
| 2.63 | | 2.48 | | 2.78 | | 2.64 | |
| 2.65 | | 1.81 | | 2.65 | | 1.81 | |
| 1.81 | | 1.81 | | 1.81 | | 1.81 | |

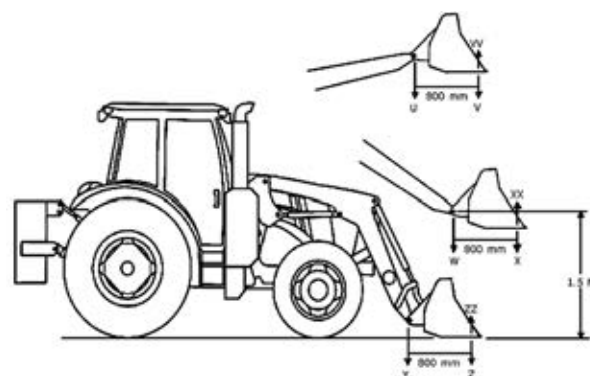
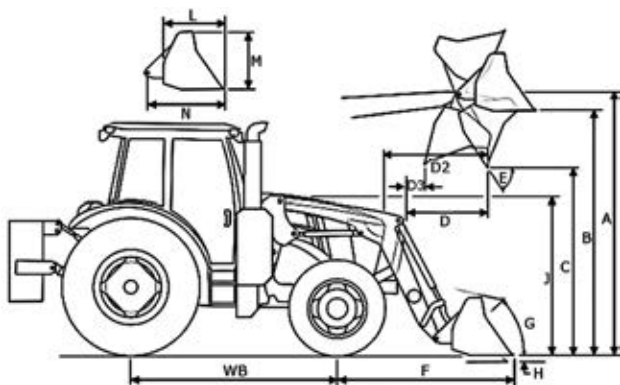

LOADER SPECIFICATIONS

| MODEL | | | | 6145R/6155R | | 6145R/6155R | | |
|---|----------------------------------|------|---------|---------------------|-------|---------------------|-------|-------|
| Front tyre | | | | 480/70R28 | | 480/70R28 | | |
| Rear tyre | | | | 580/70R38 | | 580/70R38 | | |
| Wheelbase | | (WB) | in/mm | 108.9/2,765 | | 108.9/2,765 | | |
| Pump capacity | | | gpm/lpm | 30/114 | | 30/114 | | |
| Rated pressure | | | psi/BAR | 2,900/200 | | 2,900/200 | | |
| LOADER | | | | 643R NSL | | 643R MSL | | |
| Bucket | | | | Heavy duty 2,200 mm | | Heavy duty 2,200 mm | | |
| Bucket weight | | | lb/kg | 683 | 310 | 683 | 310 | |
| Lift capacity @ full height | Measured @ Pivot | | (U) | lb/kg | 5,712 | 2,591 | 4,941 | 2,241 |
| | Measured @ 500 mm ahead of Pivot | | (V) | lb/kg | – | – | – | – |
| | Measured @ 800 mm ahead of Pivot | | (V) | lb/kg | 4,006 | 1,817 | 5,024 | 2,279 |
| Lift capacity @ 59 in (1.5 m) lift height | Measured @ Pivot | | (W) | lb/kg | 6,146 | 2,788 | 5,878 | 2,666 |
| | Measured @ 500 mm ahead of Pivot | | (X) | lb/kg | – | – | – | – |
| | Measured @ 800 mm ahead of Pivot | | (X) | lb/kg | 4,806 | 2,180 | 5,516 | 2,502 |
| Boom breakout | Measured @ Pivot | | (Y) | lb/kg | 6,493 | 2,945 | 6,684 | 3,032 |
| | Measured @ 500 mm ahead of Pivot | | (Z) | lb/kg | – | – | – | – |
| | Measured @ 800 mm ahead of Pivot | | (Z) | lb/kg | 4,824 | 2,188 | 5,754 | 2,610 |
| Bucket rollback force | @ Maximum height | | (VV) | lb/kg | 5,399 | 2,449 | 5,622 | 2,550 |
| | @ 59 in (1.5 m) lift height | | (XX) | lb/kg | 9,577 | 4,344 | 9,636 | 4,371 |
| | @ Ground level | | (ZZ) | lb/kg | 9,758 | 4,426 | 9,632 | 4,369 |
| Maximum lift height | | | (A) | in/mm | 169 | 4,300 | 169 | 4,300 |
| Clearance | @ Full height – Bucket level | | (B) | in/mm | 159 | 4,030 | 159 | 4,030 |
| | @ Full height – Bucket dumped | | (C) | in/mm | 129 | 3,281 | 128 | 3,260 |
| Overall length | | | (WB+F) | in/mm | 217 | 5,503 | 217 | 5,503 |
| Digging depth | | | (H) | in/mm | -6 | -145 | -6 | -145 |
| Reach | @ Maximum height | | (D) | in/mm | 33 | 841 | 33 | 841 |
| | @ Ground – Bucket level | | (F) | in/mm | 108 | 2,738 | 108 | 2,738 |
| Bucket angles | Dump angle @ full height | | (E) | degrees | -56 | | -60 | |
| | Rollback @ ground | | (G) | degrees | 48 | | 48 | |
| | Dump angle @ ground | | | degrees | -144 | | -117 | |
| Cycle times | Loader raise | | | sec | 3.70 | | 3.52 | |
| | Loader lower | | | sec | 2.78 | | 2.64 | |
| | Bucket dump | | | sec | 2.65 | | 1.81 | |
| | Bucket rollback | | | sec | 1.81 | | 1.81 | |

| 6135R | | 6135R | | 6145R/6155R | | 6145R/6155R | |
|---------------------|-------|---------------------|-------|---------------------|-------|---------------------|-------|
| 540/65R30 | | 540/65R30 | | 540/65R30 | | 540/65R30 | |
| 650/65R42 | | 650/65R42 | | 650/65R42 | | 650/65R42 | |
| 108.9/2,765 | | 108.9/2,765 | | 108.9/2,765 | | 108.9/2,765 | |
| 30/114 | | 30/114 | | 30/114 | | 30/114 | |
| 2,900/200 | | 2,900/200 | | 2,900/200 | | 2,900/200 | |
| 663R NSL | | 663R MSL | | 663R NSL | | 663R MSL | |
| Heavy duty 2,450 mm | | Heavy duty 2,450 mm | | Heavy duty 2,450 mm | | Heavy duty 2,450 mm | |
| 783 | 355 | 783 | 355 | 783 | 355 | 783 | 355 |
| 5,721 | 2,595 | 5,165 | 2,343 | 5,602 | 2,541 | 5,051 | 2,291 |
| - | - | - | - | - | - | - | - |
| 4,134 | 1,875 | 5,269 | 2,390 | 4,065 | 1,844 | 5,130 | 2,327 |
| 6,146 | 2,788 | 6,204 | 2,814 | 6,142 | 2,786 | 6,180 | 2,803 |
| - | - | - | - | - | - | - | - |
| 4,874 | 2,211 | 5,829 | 2,644 | 4,872 | 2,210 | 5,820 | 2,640 |
| 6,398 | 2,902 | 7,033 | 3,190 | 6,493 | 2,945 | 7,083 | 3,213 |
| - | - | - | - | - | - | - | - |
| 4,837 | 2,194 | 6,113 | 2,773 | 4,921 | 2,232 | 6,191 | 2,808 |
| 6,012 | 2,727 | 6,014 | 2,728 | 6,074 | 2,755 | 6,074 | 2,755 |
| 9,989 | 4,531 | 9,976 | 4,525 | 9,972 | 4,523 | 9,960 | 4,518 |
| 10,018 | 4,544 | 9,998 | 4,535 | 10,040 | 4,554 | 10,009 | 4,540 |
| 179 | 4,555 | 179 | 4,555 | 177 | 4,495 | 177 | 4,495 |
| 169 | 4,285 | 169 | 4,285 | 166 | 4,225 | 166 | 4,225 |
| 139 | 3,531 | 139 | 3,518 | 136 | 3,466 | 136 | 3,453 |
| 221 | 5,606 | 221 | 5,606 | 222 | 5,651 | 222 | 5,651 |
| -2 | -46 | -2 | -46 | -4 | -112 | -4 | -112 |
| 39 | 989 | 39 | 989 | 40 | 1,026 | 40 | 1,026 |
| 112 | 2,841 | 112 | 2,841 | 114 | 2,886 | 114 | 2,886 |
| -57 | | -59 | | -58 | | -60 | |
| 47 | | 47 | | 47 | | 48 | |
| -143 | | -113 | | -143 | | -114 | |
| 3.98 | | 3.91 | | 3.98 | | 3.91 | |
| 2.75 | | 2.70 | | 2.75 | | 2.70 | |
| 2.65 | | 1.81 | | 2.65 | | 1.81 | |
| 1.81 | | 1.81 | | 1.81 | | 1.81 | |

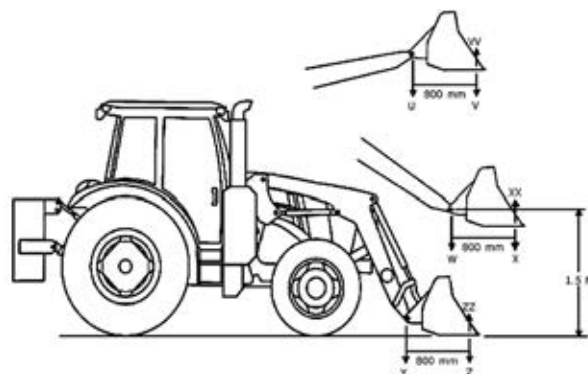
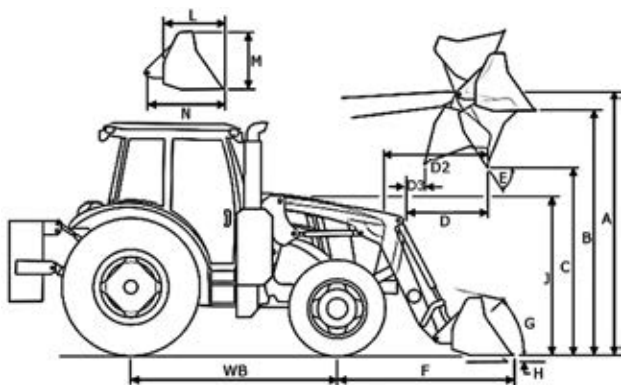

LOADER SPECIFICATIONS

| MODEL | | | | 6175R, 6195R, 6215R | |
|--|----------------------------------|--------|---------|---------------------|-------|
| Front tyre | | | | 600/65R28 | |
| Rear tyre | | | | 710/70R38 | |
| Wheelbase | | (WB) | in/mm | 110/2,800 | |
| Pump capacity | | | gpm/lpm | 30/114 | |
| Rated pressure | | | psi/BAR | 2,900/200 | |
| LOADER | | | | 663R NSL | |
| Bucket | | | | Heavy duty 2,450 mm | |
| Bucket weight | | | lb/kg | 783 | 355 |
| Lift capacity* @ full height | Measured @ Pivot | (U) | lb/kg | 5,650 | 2,563 |
| | Measured @ 800 mm ahead of Pivot | (V) | lb/kg | 4,094 | 1,857 |
| Lift capacity* @ 59 in (1.5 m) lift height | Measured @ Pivot | (W) | lb/kg | 6,144 | 2,787 |
| | Measured @ 800 mm ahead of Pivot | (X) | lb/kg | 4,874 | 2,211 |
| Boom breakout | Measured @ Pivot | (Y) | lb/kg | 6,455 | 2,928 |
| | Measured @ 800 mm ahead of Pivot | (Z) | lb/kg | 4,888 | 2,217 |
| Bucket rollback force | @ Maximum height | (VV) | lb/kg | 6,049 | 2,744 |
| | @ 59 in (1.5 m) LIFT HEIGHT | (XX) | lb/kg | 9,978 | 4,526 |
| | @ Ground level | (ZZ) | lb/kg | 10,031 | 4,550 |
| Maximum lift height* | | (A) | in/mm | 178 | 4,520 |
| Clearance* | @ Full height – Bucket level | (B) | in/mm | 167 | 4,249 |
| | @ Full height – Bucket dumped | (C) | in/mm | 137 | 3,492 |
| Overall length* | | (WB+F) | in/mm | 223 | 5,668 |
| Digging depth* | | (H) | in/mm | -3 | -85 |
| Reach* | @ Maximum height | (D) | in/mm | 40 | 1,004 |
| | @ Ground – Bucket level | (F) | in/mm | 113 | 2,868 |
| Bucket angles | Dump angle @ full height | (E) | degrees | -56 | |
| | Rollback @ ground | (G) | degrees | 48 | |
| | Dump angle @ ground | | degrees | -143 | |
| Cycle times | Loader raise | | sec | 3.98 | |
| | Loader lower | | sec | 2.75 | |
| | Bucket dump | | sec | 2.65 | |
| | Bucket rollback | | sec | 1.81 | |

*The values may vary according to the tractor and loader settings/configuration.

| 6175R, 6195R, 6215R | | 6175R, 6195R, 6215R | | 6230R, 6250R | |
|---------------------|-------|---------------------|-------|---------------------|-------|
| 600/65R28 | | 600/65R28 | | 600/70R30 | |
| 710/70R38 | | 710/70R38 | | 650/85R38 | |
| 110/2,800 | | 110/2,800 | | 110/2,800 | |
| 30/114 | | 30/114 | | 30/114 | |
| 2,900/200 | | 2,900/200 | | 2,900 | |
| 663R MSL | | 683R MSL | | 683R MSL | |
| Heavy duty 2,450 mm | | Heavy duty 2,450 mm | | Heavy duty 2,450 mm | |
| 783 | 355 | 783 | 355 | 783 | 355 |
| 5,097 | 2,312 | 5,501 | 2,495 | 5,560 | 2,522 |
| 5,185 | 2,352 | 5,525 | 2,506 | 5,595 | 2,538 |
| 6,191 | 2,808 | 6,691 | 3,035 | 6,704 | 3,041 |
| 5,825 | 2,642 | 6,323 | 2,868 | 6,327 | 2,870 |
| 7,064 | 3,204 | 7,606 | 3,450 | 7,573 | 3,435 |
| 6,160 | 2,794 | 6,702 | 3,040 | 6,649 | 3,016 |
| 6,049 | 2,744 | 6,590 | 2,989 | 6,552 | 2,972 |
| 9,967 | 4,521 | 9,835 | 4,461 | 9,841 | 4,464 |
| 10,005 | 4,538 | 9,753 | 4,424 | 9,747 | 4,421 |
| 178 | 4,520 | 176 | 4,480 | 178 | 4,520 |
| 167 | 4,249 | 166 | 4,209 | 167 | 4,250 |
| 137 | 3,480 | 135 | 3,437 | 137 | 3,480 |
| 223 | 5,668 | 227 | 5,769 | 228 | 5,791 |
| -3 | -85 | -5 | -126 | -3 | -85 |
| 40 | 1,004 | 53 | 1,335 | 48 | 1,215 |
| 113 | 2,868 | 117 | 2,969 | 114 | 2,891 |
| -56 | | -56 | | -56 | |
| 48 | | 48 | | 53 | |
| -114 | | -116 | | -117 | |
| 3.91 | | 4.19 | | 4.19 | |
| 2.70 | | 2.89 | | 2.89 | |
| 1.81 | | 1.81 | | 1.81 | |
| 1.81 | | 1.81 | | 1.81 | |

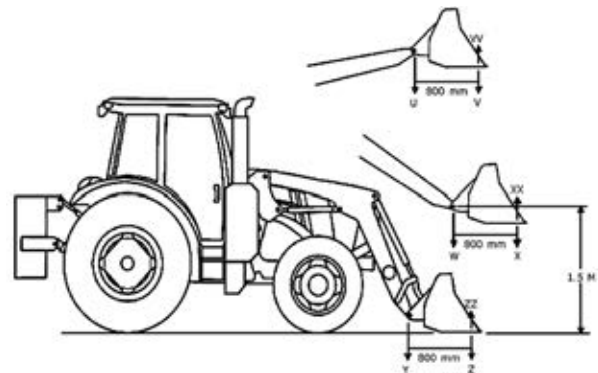
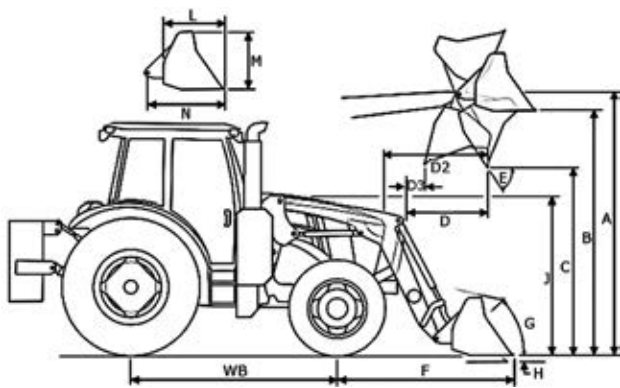

NOTHING RUNS LIKE A DEERE

Chances are that when you need us, you need us right then and there. For advice, to solve a problem, or for a part. Reach out, we'll be there with technicians who are factory trained, ready to go to work for you, using only genuine John Deere parts and products. Our commitment to quality doesn't stop at your machine – we also have financing options available that are guaranteed to fit your budget and your plans.



This literature has been compiled for worldwide circulation. While general information, pictures and descriptions are provided, some illustrations and text may include finance, credit, insurance, product options and accessories not available in all regions. Please contact your local dealer for details. John Deere reserves the right to change specification and design of products described in this literature without notice. The green and yellow colour scheme, the leaping deer logo and the JOHN DEERE word mark are trademarks of Deere & Company.