

# Hiab XS 700

## Capacity 66 tm



# Hiab XS 700 Basic data

<b>Technical data</b>	<b>EP-5 HiPro</b>	<b>E-6 HiPro</b>	<b>E-7 HiPro</b>	<b>E-9 HiPro</b>
Max. lifting capacity (kNm)	620	606	600	590
Outreach - hydraulic extensions (m)	14.8	16.1	18.4	22.8
Outreach - manual extensions (m)	-	-	-	-
Outreach - jib (m)	-	-	27.2	-
Outreach / Lifting capacity, standard (m / kg)	3.3 / 17800	3.3 / 17900	3.3 / 17600	3.2 / 17500
	4.7 / 13400	4.3 / 14300	4.4 / 13900	4.5 / 13000
	6.3 / 9800	5.9 / 10200	6.0 / 9800	6.1 / 9400
	8.2 / 7400	7.7 / 7500	7.8 / 7300	7.9 / 6900
	10.2 / 5800	9.6 / 5900	9.7 / 5600	9.8 / 5200
	12.4 / 4700	11.6 / 4700	11.7 / 4500	11.8 / 4100
	14.7 / 4000	13.7 / 3900	13.8 / 3700	13.9 / 3400
	-	15.9 / 3400	16.0 / 3100	16.1 / 2800
	-	-	18.2 / 2700	18.3 / 2400
	-	-	-	20.5 / 2100
	-	-	-	22.6 / 1920
Outreach / Lifting capacity, with jib (m / kg)	-	-	21.0 / 1440	-
	-	-	22.4 / 1320	-
	-	-	23.9 / 1220	-
	-	-	25.5 / 1130	-
	-	-	27.1 / 1050	-
Slewing angle	∞	∞	∞	∞
Height in folded position (mm)	2555	2470	2470	2517
Width in folded position (mm)	2500	2500	2500	2500
Installation space needed (mm)	1436	1569	1569	1569
Weight - "standard" crane without stabilizers (kg)	5960	6410	6655	7020
Weight - stabilizer equipment (kg)	1180 - 1305	1180 - 1305	1180 - 1305	1180 - 1305
Weight - jib (kg)	-	-	1000	-

**Hiab XS 700 E-9 HiPro**

Min. 4625 Max. 22817

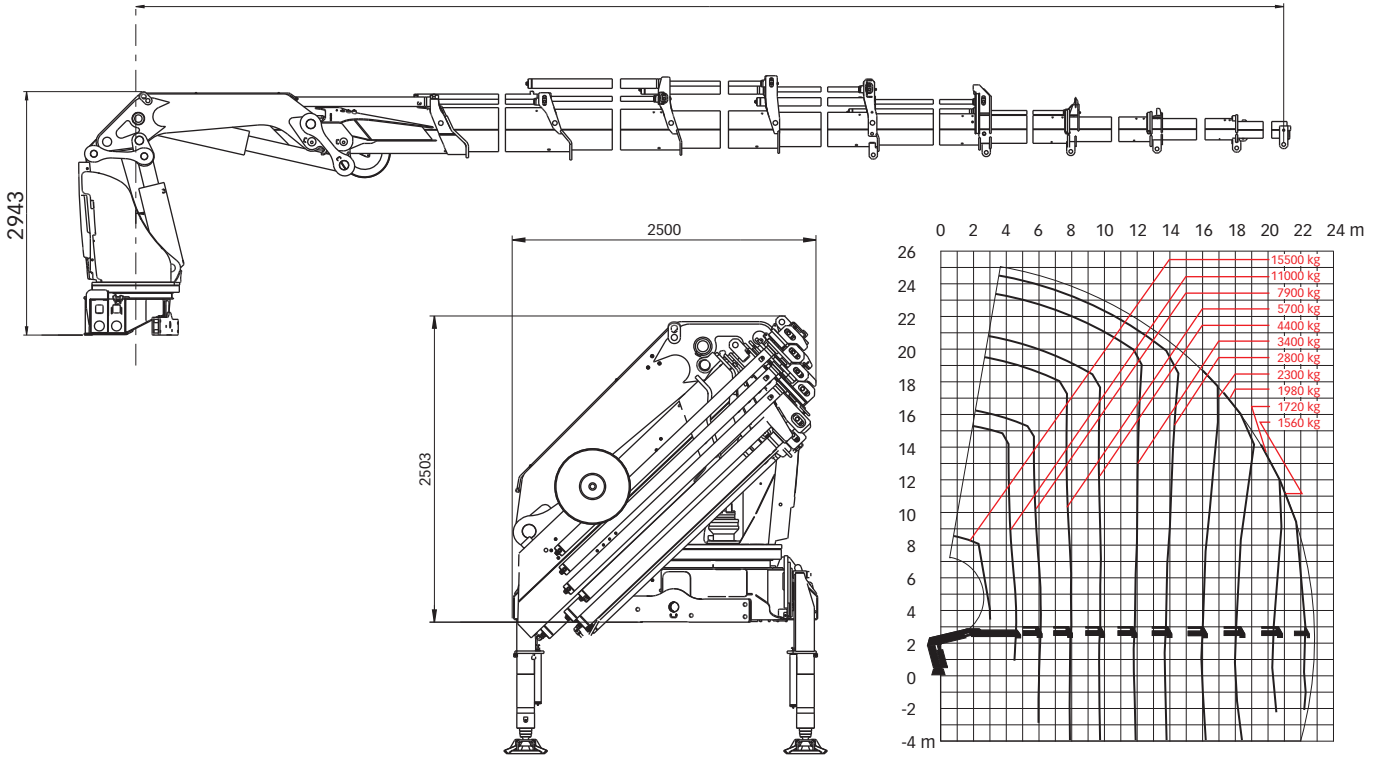

**Hiab XS 700 E-7 jib 135X-4**

Min. 7516 Max. 27286

Min. 2740 Max. 8940

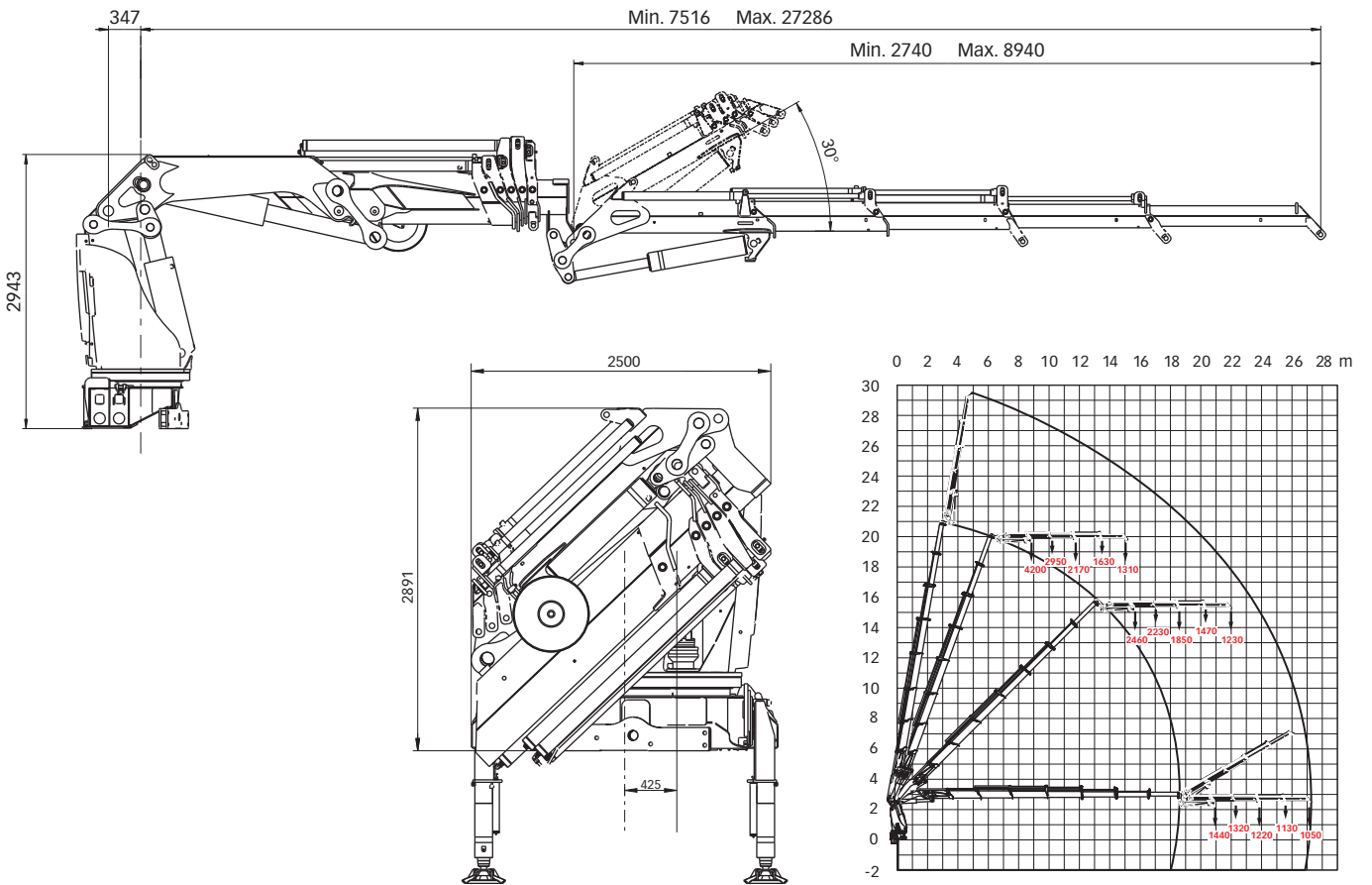

**Disclaimer.** Hiab cranes have been built to meet the highest standards of safety and service life and have been thoroughly tested. Strength calculations for this model have been carried out in accordance with EN13001 in fatigue class S0. Cargotec's certified Quality Assurance System complies with ISO 9001. Some of the items in our literature may be extra equipment. Certain applications may require an official permit. We reserve the right to change technical specifications without prior notice. Hiab cranes produced for EU-countries are CE-marked and comply with the European Standard EN 12999.

**Cargotec** improves the efficiency of cargo flows by offering solutions for the loading and unloading of goods on land and at sea – wherever cargo is on the move. Cargotec's main daughter brands for cargo handling Hiab, Kalmar and MacGregor are global market leaders in their fields. [www.cargotec.com](http://www.cargotec.com)

