

Great all-round strength



DanTruck

Unique industrial design, solid rugged power, innovation and thorough understanding of the individual customer's requirements. Those are some of the characteristics which make DanTruck A/S one of Europe's leading manufacturers of medium-heavy forklifts.

As a customer, you will gain a partner who prioritises power, safety, comfort and the environment. As a result of our purposeful development work, we are able to offer forklifts characterised by great all-round strength. Together we can provide smooth, highly productive machines yet at the same time being ever-conscious of the environment and low operating costs.

DanTruck A/S takes pride in increasing the quality of its products and being at the leading edge of the technological development. We look to the future, while at the same time building on our broad and long experience of constructing extremely versatile, customised forklifts.

DanTruck A/S has an international sales and service network. You can read more about this at our website dantruck.com, where you can also find our nearest dealer.

DanTruck 9000 Power+

DIESEL . FOUR CYLINDER . 6-9 TONNES



Dealer:

DT 000017

DanTruck 9000 Power+

VDI 2198

DIESEL . FOUR CYLINDER . 6-9 TONNES

GENERAL INFORMATION			DanTruck Power+	DanTruck Power+	DanTruck Power+	DanTruck Power+	DanTruck Power+
Brand			DanTruck Power+	DanTruck Power+	DanTruck Power+	DanTruck Power+	DanTruck Power+
Model			9466	9476	9486	9496	9489
Power source			Diesel	Diesel	Diesel	Diesel	Diesel
Operation			Seated operator	Seated operator	Seated operator	Seated operator	Seated operator
Load capacity	Q	t	6	7	8	9	8
Load centre	c	mm	600	600	600	600	900
Load distance	x	mm	670	680	690	695	700
Wheelbase	y	mm	2295	2295	2395	2545	2545
Unladen weight		kg	10500	10800	11700	12500	14400
Axle load, with load, front/rear		kg	14900/1600	16000/1800	17700/2000	19000/2500	20400/2000
Axle load, without load, front/rear		kg	5500/5000	5500/5300	6000/5700	6000/6500	7400/7000
Tyre type, front/rear (S=Super-elastic, L=Pneumatic)			S-L	S-L	S-L	S-L	S-L
Size, front			355/65-15	355/65-15	8,25-15	8,25-15	300-15
Size, rear			8,25-15	8,25-15	8,25-15	300-15	300-15
Number, front/rear			2/2	2/2	4/2	4/2	4/2
Track width, tyre centre, front	b10	mm	1590	1590	1520	1520	1580
Track width, tyre centre, rear	b11	mm	1535	1535	1535	1495	1495
Mast tilt, forward/backward		grad	6/9	6/9	6/9	6/9	6/9
Mast height, lowered (Duplex)	h1	mm	2710	2710	3010	3160	3160
Free lift	h2	mm	-	-	-	-	-
Lift height	h3	mm	3600	3600	3600	3600	3600
Mast height, extended	h4	mm	4510	4510	4810	4960	4960
Overhead guard height	h6	mm	2705	2705	2705	2705	2705
Seat height	h7	mm	1600	1600	1600	1600	1600
Tow bar height	h10	mm	500	500	500	500	500
Length to fork tips	l1	mm	4760	4770	4880	5035	5640
Length to face of forks	l2	mm	3560	3570	3680	3835	3840
Overall width	b1/b2	mm	1820	1820	2002	2002	2150
Forks	s/e/l	mm	50x150x1200	60x150x1200	60x150x1200	65x150x1200	70x180x1800
Fork carriage DIN 15173, Class, Type A,B			4A	4A	4A	4A	4A
Carriage width	b3	mm	1800	1800	2000	2000	2100
Ground clearance, below mast	m1	mm	250	250	250	250	250
Ground clearance, centre of wheelbase	m2	mm	250	250	250	250	250
Aisle width, pallet 1000 x 1200 sideways	Ast	mm	5120	5130	5240	5545	-
Aisle width, pallet 800 x 1200 lengthways	Ast	mm	5320	5330	5440	5745	-
Turning radius	Wa	mm	3250	3250	3350	3650	3650
Min. turning distance	b13	mm	1270	1270	1320	1390	1390
Travelling speed, with/without load		km/h	22,4/22,6	22,4/22,6	22,4/22,6	22,4/22,6	22,4/22,6
Lifting speed, with/without load		m/s	0,39/0,60	0,39/0,60	0,39/0,60	0,39/0,60	0,39/0,60
Lowering speed, with/without load		m/s	0,50/0,36	0,50/0,36	0,50/0,36	0,50/0,36	0,50/0,36
Drawbar pull, with/without load @ 10% rated speed		N	49570/49570	49570/49570	49570/49570	49570/49570	49570/ 9570
Gradeability, with/without load @ 10% rated speed		%	30,3/ -	28,7/ -	27,1/ -	24,6/ -	21,5/ -
Acceleration time, with/without load		s	6/5	6/5	6/5	7/6	7/6
Service brake			hydraulisk	hydraulisk	hydraulisk	hydraulisk	hydraulisk
Make			Perkins	Perkins	Perkins	Perkins	Perkins
Type			1104D E44TA	1104D E44TA	1104D E44TA	1104D E44TA	1104D E44TA
Rated output in accordance with ISO 1585		kW	91	91	91	91	91
Torque		Nm	490 @ 1400 rpm	490 @ 1400 rpm	490 @ 1400 rpm	490 @ 1400 rpm	490 @ 1400 rpm
Engine speed		1/min	2200	2200	2200	2200	2200
No. of cylinders/displacement			4/4,4 l	4/4,4 l	4/4,4 l	4/4,4 l	4/4,4 l
Fuel consumption in accordance with VDI cycle		kg/h					
Fuel injection system			electronic	electronic	electronic	electronic	electronic
Transmission			Hydrodyn. 2-2	Hydrodyn. 2-2	Hydrodyn. 2-2	Hydrodyn. 2-2	Hydrodyn. 2-2
Make/type			DANA TE08	DANA TE08	DANA TE08	DANA TE08	DANA TE08
Hydraulic pumps, A = variable/C = gear			A/C	A/C	A/C	A/C	A/C
Operating pressure for attachments		bar	160	160	160	160	160
Oil flow for attachments		l/min	80	80	80	80	80
Noise level at operator's ear, EN 12053		LpA dB	70	70	70	70	70

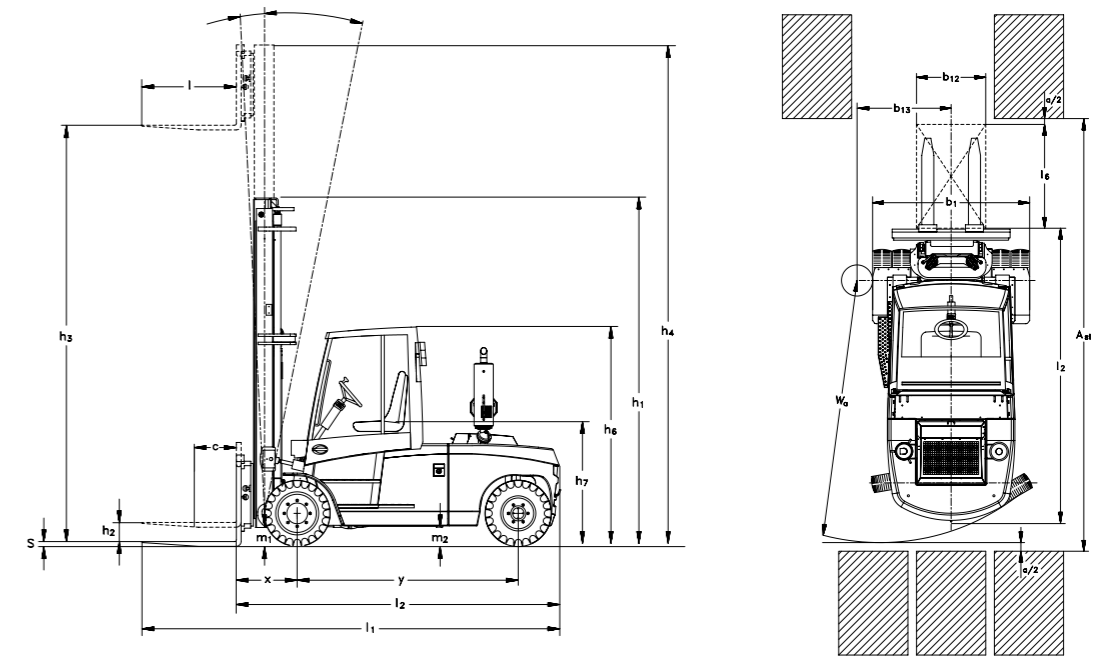

MAST PROGRAM FOR 6/7 T WITH 600 MM LOAD CENTRE

	mm	3600	4000	4500	5000	5500	6000	6500			
Lift height	mm	3600	4000	4500	5000	5500	6000	6500			
Mast height	h1	2750	2910	3160	3410	3660	3910	4160			
Free lift	h4	0	0	0	0	0	0	0			
Lift height	mm	3600	4000	4500	5000	5500	6000	6500			
Mast height	h1	2875	3075	3325	3575	3825	4075	4325			
Free lift	h4	1800	2000	2250	2500	2750	3000	3300			
Lift height	mm				5000	5500	6000	6500	7000	7500	8000
Mast height	h1				2752	2918	3085	3252	3418	3585	3752
Free lift	h4				1667	1833	2000	2167	2333	2500	2667

MAST PROGRAM FOR 8 T WITH 600 MM LOAD CENTRE

	mm	3600	4000	4500	5000	5500	6000	6500			
Lift height	mm	3600	4000	4500	5000	5500	6000	6500			
Mast height	h1	3010	3210	3460	3710	3960	4210	4460			
Free lift	h4	0	0	0	0	0	0	0			
Lift height	mm	3600	4000	4500	5000	5500	6000	6500			
Mast height	h1	3025	3225	3475	3725	3975	4225	4475			
Free lift	h4	1800	2000	2250	2500	2750	3000	3300			
Lift height	mm			4500	5000	5500	6000	6500	7000	7500	8000
Mast height	h1			2735	2902	3068	3235	3402	3568	3735	3902
Free lift	h4			1500	1667	1833	2000	2167	2333	2500	2667

MAST PROGRAM FOR 8 T WITH 900 MM/9 T WITH 600 MM LOAD CENTRE

	mm	3600	4000	4500	5000	5500	6000	6500			
Lift height	mm	3600	4000	4500	5000	5500	6000	6500			
Mast height	h1	3160	3360	3610	3860	4110	4360	4610			
Free lift	h4	0	0	0	0	0	0	0			
Lift height	mm	3300	3600	4000	4500	5000	5500	6000	6500		
Mast height	h1	3025	3175	3375	3625	3875	4125	4375	4625		
Free lift	h4	1650	1800	2000	2250	2500	2750	3000	3300		
Lift height	mm			4500	5000	5500	6000	6500	7000	7500	8000
Mast height	h1			2885	3052	3218	3385	3552	3718	3885	4052
Free lift	h4			1500	1667	1833	2000	2167	2333	2500	2667

MAST PROGRAM FOR 9 T WITH 900 MM LOAD CENTRE

	mm	3600	4000	4500	5000	5500	6000	6500				
Lift height	mm	3600	4000	4500	5000	5500	6000	6500				
Mast height	h1	3310	3510	3760	4010	4260	4510	4760				
Free lift	h4	0	0	0	0	0	0	0				
Lift height	mm	3300	3600	4000	4500	5000	5500	6000	6500			
Mast height	h1	3175	3325	3525	3775	4025	4275	4525	4775			
Free lift	h4	1650	1800	2000	2250	2500	2750	3000	3300			
Lift height	mm			4000	4500	5000	5500	6000	6500	7000	7500	8000
Mast height	h1			2868	3035	3202	3368	3535	3702	3868	4035	4202
Free lift	h4			1333	1500	1667	1833	2000	2167	2333	2500	2667