



**Specifications**

**FC 4500 Series**

Four Wheel  
Counterbalance Truck

# FC 4500

# Series



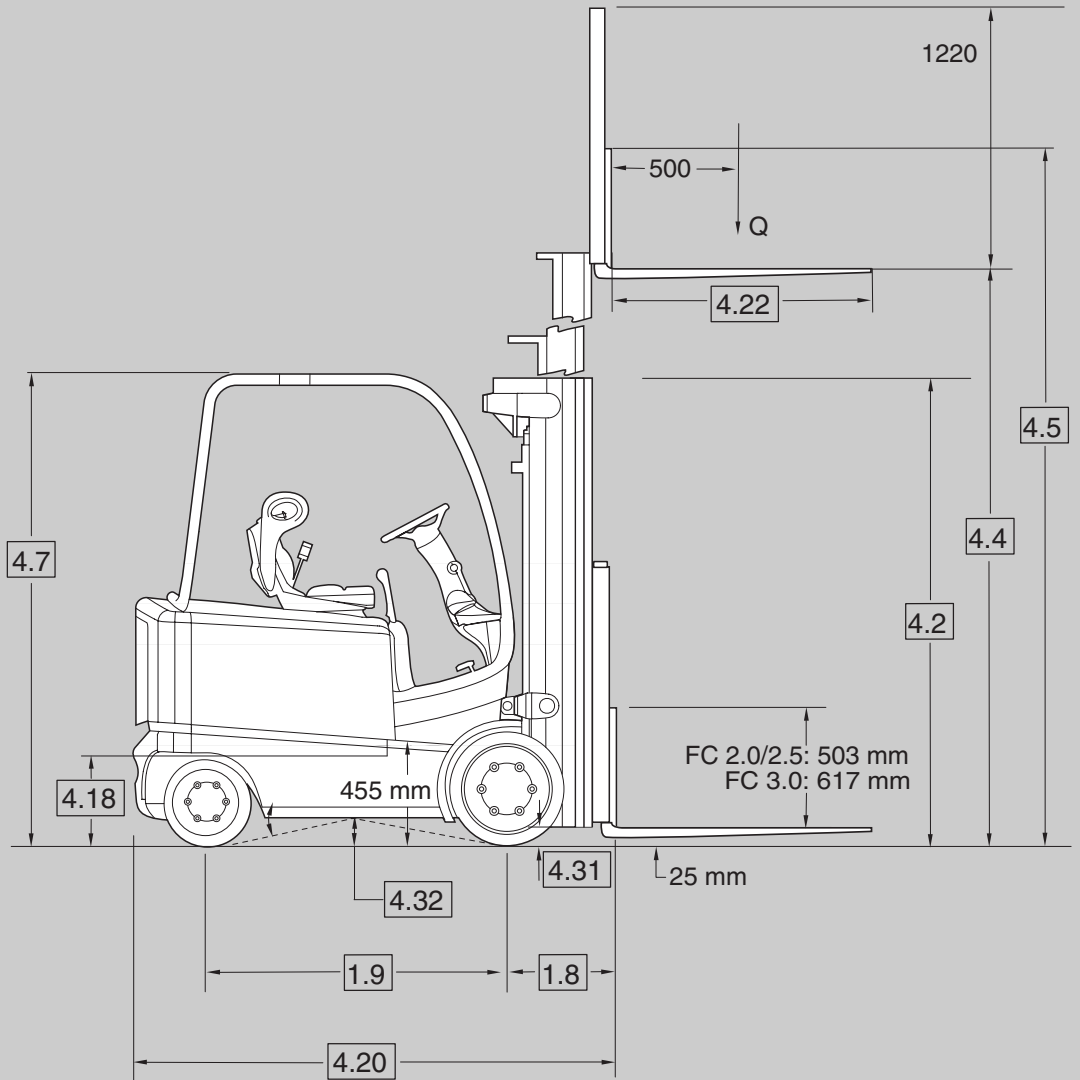
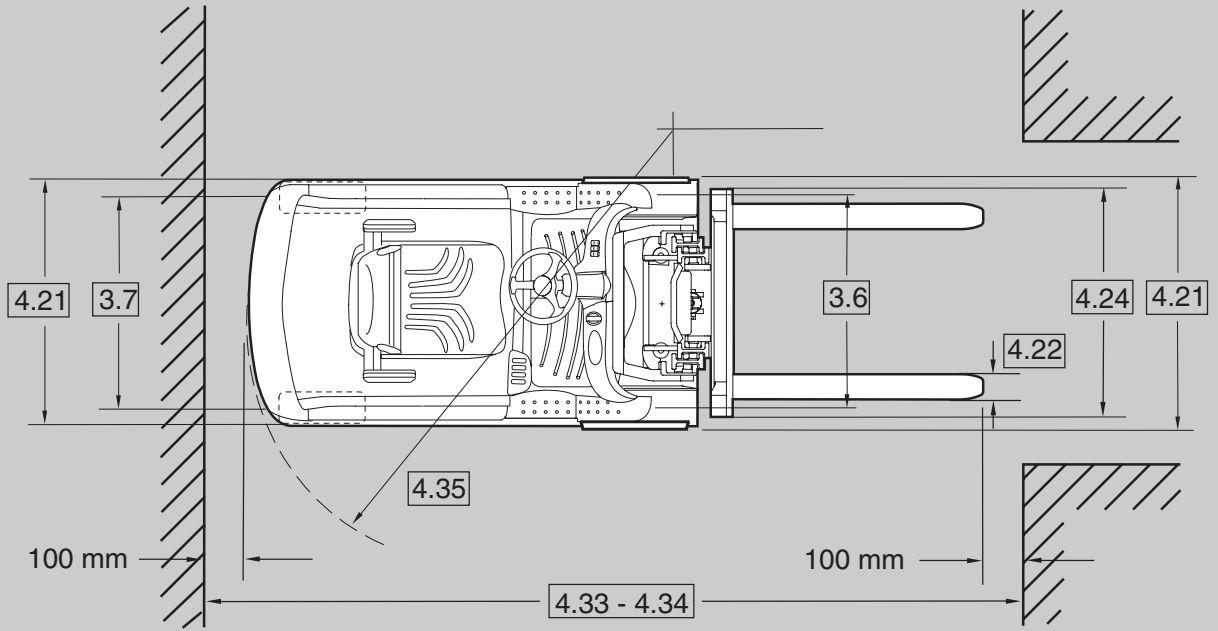

General Information	1.1	<b>Manufacturer</b>				
	1.2	<b>Model</b>				FC 4510 - 2.0
						FC 4515 - 2.0
	1.3	<b>Power</b>				
	1.4	<b>Operator Type</b>				
	1.5	<b>Load Capacity</b>		Q	t	2.0
	1.6	<b>Load Centre</b>		c	mm	
	1.8	<b>Load Distance</b>		x	mm	
1.9	<b>Wheel Base</b>		y	mm	1262	
Weights	2.1	<b>Weight</b>	less battery		kg	3225
	2.2	<b>Axle Load</b>	w. load front / rear		kg	5337 / 840
	2.3	<b>Axle Load</b>	w.o. load front / rear		kg	2131 / 2264
Tyres	3.1	<b>Tyre Type</b>				
	3.2	<b>Wheel Size</b>	front		inch / mm	21 x 7 - 15"
			rear		inch / mm	16 x 6 x 10,5"
	3.5	<b>Wheels</b>	number (x=driven) front / rear			
	3.6	<b>Track Width</b>	front, standard / option	b10	mm	925
			rear	b11	mm	
3.7						
Dimensions	4.1	<b>Mast Tilt</b>	forward / backward	degree	°	
	4.2	<b>Mast</b>	collapsed height	h1	mm	
	4.3	<b>Free Lift</b>	w.o. load backrest	h2	mm	
	4.4	<b>Lift Height</b>		h3	mm	
	4.5	<b>Mast</b>	extended height, w.o. load backrest	h4	mm	
	4.7	<b>Overhead Guard Height</b>		h6	mm	
	4.8	<b>Seat Height</b>	static / suspension seat	h7	mm	
	4.12	<b>Tow Hitch Height</b>		h10	mm	
	4.15	<b>Lowered Fork Height</b>		h13	mm	
	4.18	<b>Battery Floor Height</b>	w. / w.o. rollers		mm	
	4.20	<b>Headlength</b>		l2	mm	1976
	4.21	<b>Overall Width</b>	standard front / rear		mm	
			option track enlargement front / rear		mm	
	4.22	<b>Fork Dimension</b>		thxwxl	mm	
	4.23	<b>Fork Carriage</b>	ISO class			
	4.24	<b>Fork Carriage Width</b>	incl. load backrest, standard / option	b3	mm	
	4.31	<b>Ground Clearance</b>	with load below mast	m1	mm	
	4.32	<b>Ground Clearance</b>	centre wheelbase	m2	mm	
	4.33	<b>Working Aisle Width</b>	pallets 1000 x 1200 traverse	Ast	mm	3355
	4.34	<b>Working Aisle Width</b>	pallets 800 x 1200 length	Ast	mm	3555
4.35	<b>Turning Radius</b>		Wa	mm	1755	
4.36	<b>Small. Ins. Turning Radius</b>		b13	mm	483	
Performance	5.1	<b>Travel Speed</b>	w. / w.o. load		km/h	16.4
	5.2	<b>Lift Speed DC</b>	w. / w.o. load		m/s	0.38
	5.2	<b>Lift Speed AC</b>	w. / w.o. load		m/s	0.47
	5.3	<b>Lowering Speed</b>			m/s	
	5.9	<b>Acceleration Time</b>	w. / w.o. load			5.7
	5.10	<b>Brake</b>	service / parking			
Motors	6.1	<b>Traction Motor</b>	60 min. rating		kW	
	6.2	<b>Lift Motor</b>	15% on time		kW	
	6.3	<b>Max. Battery Box Size</b>		lxwxh	mm	692 x 982 x 593
	6.4	<b>Battery Voltage</b>	nominal capacity 5h		V / Ah	48 / 675
	6.5	<b>Battery Weight</b>	min. / max.		kg	1195 / 1450
Misc.	8.1	<b>Type of Control</b>	drive / lift standard / lift option			
	8.2	<b>Available Working Pressure for Attachments</b>			bar	

**FC 4500 Series**

**Specifications**

Crown Equipment Corporation					
FC 4520 - 2.0	FC 4510 - 2.5	FC 4520 - 2.5	FC 4540 - 2.5	FC 4520 - 3.0	FC 4540 - 3.0
FC 4525 - 2.0	FC 4515 - 2.5	FC 4525 - 2.5	FC 4545 - 2.5	FC 4525 - 3.0	FC 4545 - 3.0
electric					
Sitdown Counterbalanced					
2.0	2.5			3.0	
500					
401				409	
1389	1262	1389	1389	1389	
3203	3602	3444	3319	3868	3663
5235 / 998	6062 / 936	6073 / 844	5991 / 934	6841 / 946	6713 / 1001
2160 / 2290	2055 / 2718	2232 / 2459	2150 / 2549	2219 / 2895	2092 / 2951
rubber					
/ 533 x 178 x 381	21 x 8 - 15" / 533 x 203 x 381			21 x 9 - 15" / 533 x 229 x 381	
/ 406 x 152 x 267	16 x 6 x 10,5" / 406 x 152 x 267			16 x 6 x 10,5" / 406 x 152 x 267	
2x / 2					
/ 1030	900 / 1005			920 / 990	
915					
see table 1			see table 2		
see table 1			see table 2		
see table 1			see table 2		
see table 1			see table 2		
see table 1			see table 2		
2185					
1216 / 1243					
240					
70					
442 / 434					
2134	2062	2134	2212	2228	2306
1105 / 1100			1145 / 1100		
1207 / 1100			1220 / 1100		
45 x 100 x 800 / 915 / 1065 / 1100 / 1145 / 1220 / 1370 / 1525				45 x 125 x 915 / 1065 / 1220 / 1370 / 1525	
2 A			3 A		
965 / 1120					
76					
122					
3515	3430	3515	3582	3595	3665
3715	3630	3716	3782	3795	3865
1913	1826	1915	1981	1986	2055
534	483	534	534	534	534
/ 17.7	15.9 / 17.5			15.3 / 17.4	
/ 0.56	0.36 / 0.56			0.34 / 0.56	
/ 0.56	0.44 / 0.56			0.39 / 0.56	
0.43					
/ 5.4	5.9 / 5.4			6.1 / 5.5	
hydraulic					
11.6					
11.5					
836 x 982 x 593	692 x 982 x 593	836 x 982 x 593	924 x 982 x 593	836 x 982 x 593	924 x 982 x 593
48 / 900	48 / 675	48 / 900	48 / 900	48 / 900	48 / 900
1270 / 1815	1260 / 1450	1310 / 1815	1405 / 1930	1445 / 1815	1405 / 1930
AC control / contactor / AC control					
210					

Table 1 Mast Chart FC 4500 2.0 & 2.5				TL			TT							
4.4	Lift Height	h3	mm	3200	3505	3810	4775	5230	5485	5865	6245	6555	7010	7390
4.5	Mast, Extended Height w.o. LBR	h4	mm	3790	4095	4400	5390	5850	6100	6485	6865	7120	7630	8010
	Mast, Extended Height with LBR	h4	mm	4420	4725	5030	5995	6450	6705	7085	7465	7775	8230	8610
4.2	Mast, Collapsed Height	h1	mm	2110	2260	2415	2110	2260	2415	2565	2720	2870	3025	3175
4.3	Free Lift w.o. Load Backrest	h2	mm	140	140	140	1490	1640	1795	1950	2100	2255	2405	2255
	Free Lift with Load Backrest	h2	mm	140	140	140	815	970	1120	1275	1425	1580	1730	1885
4.1	Mast Tilt forward/backward		°	5 / 5			5 / 5							
	Tilt forward ltd. to 2° at LH above		mm	1980	1980	1980	1675	1830	1980	2135	2285	2440	2590	2745

Table 1 Mast Chart FC 4500 2.0 & 2.5				Quad				
4.4	Lift Height	h3	mm	6095	6550	7010	7465	7925
4.5	Mast, Extended Height w.o. LBR	h4	mm	6755	7215	7670	8125	8585
	Mast, Extended Height with LBR	h4	mm	7315	7770	8230	8685	9145
4.2	Mast, Collapsed Height	h1	mm	2110	2260	2415	2566	2720
4.3	Free Lift w.o. Load Backrest	h2	mm	1490	1695	1795	1950	2100
	Free Lift with Load Backrest	h2	mm	805	1010	1110	1265	1415
4.1	Mast Tilt forward/backward		°	5 / 3				
	Tilt forward ltd. to 2° at LH above		mm	1930	2085	2235	2390	2540

Table 2 Mast Chart FC 4500 3.0				TL			TT					
4.4	Lift Height	h3	mm	2995	3300	3605	4570	5030	5280	5665	6045	6350
4.5	Mast, Extended Height w.o. LBR	h4	mm	3615	3920	4225	5190	5650	5900	6285	6665	6970
	Mast, Extended Height with LBR	h4	mm	4215	4520	4825	5790	6250	6500	6885	7265	7570
4.2	Mast, Collapsed Height	h1	mm	2110	2260	2415	2110	2260	2415	2565	2720	2870
4.3	Free Lift w.o. Load Backrest	h2	mm	150	150	150	1490	1640	1795	1950	2100	2255
	Free Lift with Load Backrest	h2	mm	150	150	150	815	970	1120	1275	1425	1580
4.1	Mast Tilt forward/backward		°	5 / 5			5 / 5					
	Tilt forward ltd. to 2° at LH above		mm	1980	1980	1980	1675	1830	1980	2135	2285	2440

**Standard Equipment**

- Crown's Access 1 2 3™ Comprehensive System Control
- Intrinsic stability system™
  - Travel speed reduction when above mast staging
  - Forward tilt interlock above staging
  - Counterweight exceeds required standards
  - Ramp speed control
- Operator entry/exit
  - 455 mm step height
  - Large entry/exit "window"
  - Tubular overhead guard upright for easy hand hold
  - Formed battery seat deck
  - Rounded floorboard edges
  - Tilt steering wheel and sculpted column
  - Large, uncluttered floorboard
- Operator compartment design features
  - Low dashboard for fork and floor visibility
  - Wide visibility window between overhead guard and front column
  - Suspension seat with adjustable armrest, shoulder restraint and anti cinch seat belt

- Infinite adjustment steering wheel column and steering wheel spinner knob
  - Fingertip applied/released parking brake with audible alarm
  - Urethane covered control handles with tactile feedback
  - Natural position for forward/reverse direction selector
  - Rubber floor mat/rubber covered pedals
- AC traction system
  - Exclusive Crown power disc brake with regenerative motor plugging
  - Crown-manufactured lift motor
  - 48-volt system
  - Crown display
    - Battery discharge indicator with lift interrupt and re-key feature
    - Hour meters / travel distance / stop watch
    - Pin code access capable
    - Event code display with five (5) key navigation
    - Access 1 2 3 diagnostics
    - P1, P2, P3 Performance tuning
  - High visibility mast with in-line hose routing

- Waterfall design overhead guard
- Lift out or side removal battery access
- Battery side retainer with interlock and fault identification
- No tool lift out floorboards
- 1220 mm high load backrest
- SBE 320 blue battery connector
- Colour-coded wiring
- InfoPoint™ System
- Three-spool hydraulic valve
- Leak free O-ring face seal hydraulic fittings
- Battery disconnect handle
- Lift interrupt

**Optional Equipment**

- AC Hydraulics
- TL and quad mast styles
- Tilt Position Assist
- Special forward tilt angle
- Fork lengths
- Polished and tapered forks
- Load backrest heights
- Hydraulic valves for attachments
- Sideshifter
- Quick disconnect hydraulic connectors
- Attachment pressure regulator and gauge

- Brake activated traction cutout
- Foot operated directional control
- Automatic parking brake, (seat activated)
- Wide tread widths
- Non-marking smooth or lug rubber tyres
- Dock Performance Package
- Brush wear and motor over-temperature indicators for DC motors
- Back-up, brake and tail light
- Work lights
- Flashing lights
- Audible travel alarm
- Tow pin
- Drive-in rack overhead guard
- Storage tray with clipboard support
- Suspension seat with hip restraint
- Work Assist™ Accessories
  - Clip pad and hook
  - Accessory clamp
  - Terminal mounting
  - Work lights
  - Mirrors
- Pos/Neg accessory cable
- Full battery side doors
- Battery compartment rollers
- Freezer and corrosion conditioning

**Operator Compartment**

The FC 4500 benefits from Crown’s design and engineering excellence. Numerous features improve operator comfort and productivity.

A low 455mm step height greatly improves entry and exit on both sides of the truck. A low, streamlined battery cover helps the operator glide into the truck’s seat. The overhead guard is shaped to open up the entry/exit window and its tubular design provides a comfortable hand grip location for a variety of operator heights. The compact tilt steer column and steer wheel further facilitate entry/exit. Tilt column is spring loaded to easily move up and away. Floorboard (0,4 m²) is unobstructed and rubber covered to insulate the operator from vibration.

Better visibility can be seen everywhere you look. A low dashboard for fork and carriage visibility, a high visibility mast, a slim steer column, a formed floorboard and patented “waterfall” overhead guard all contribute to superior visibility.

Control handles are crafted into the compartment and “fanned” for easy selection. They are urethane covered with tactile feedback for comfort and easy selection. Control actuation forces are minimal and responsive.

Finger applied/released parking brake with audible signal enhances operator entry/exit and naturally encourages its use. Battery disconnect is easy to reach and operate. Easy to actuate rocker-type switches are conveniently located to select optional work lights or fan. A large horn button is integrated in the centre of the steer wheel.

**Drive System**

Crown has applied the latest generation AC drive system, enhanced with Access 1 2 3 control technology, to provide high torque and energy efficiency. The drive motor is transverse-mounted high above the floor and away from dirt and moisture. Heavy-duty triple reduction, all gear design operates in oil bath and is engineered for durability with reduced vibration and noise.

Crown’s Access 1 2 3 technology provides optimum performance and control through intelligent coordination of all truck systems and simplified service with advanced diagnostics. Three modes of performance can be selected to accommodate operator experience or application requirements.

The Crown display is used for easy troubleshooting and access to event history. A distribution panel is conveniently located with all test points, control fuses and central wiring for easy troubleshooting

**Brake System**

Service brakes are located in the wheel ends with a unique full-circle hydraulic disc design. This design reduces operator pedal effort and improves brake response. Brake service life is increased due to a large full circle friction pad. Access for inspection or replacement is direct and easy, reducing downtime for brake maintenance.

Parking brake is activated by a push button. An acoustic reminder signal is standard. Parking brake is located on the end of the motor shaft to take advantage of gear reduction. Optional seat activated automatic parking brake is available.

**Steering**

Fully hydrostatic system with equal area, double-acting cylinder provides equally responsive steering rate both ways (4.8 turns lock to lock). Rugged axle frame; forged spindle and connecting links eliminate the need for adjustment. One-piece forged spindle and kingpin in tapered roller bearings for improved life and serviceability. Spherical bearings with tapered pins in connecting links eliminate any play in linkage. All bearing locations are sealed to exclude contaminants and are equipped with lubrication fittings for ease of service. Axle articulates in rubber isolation bushing to minimize vibration and to improve truck handling and ride.

**Mast Assembly**

Large, rugged trunnion mount on drive axle and extra heavy tilt cylinders with self-aligning bushings secure the mast. The high visibility mast features a nested-rail design with lift cylinders positioned behind the rails. Heavy-duty mast is engineered to provide smooth reliable operation.

Large hydraulic hose reeves and hose placement are engineered to reduce hose wear and increase life. Routing places hoses in-line versus side-by-side to reduce visual interference. Large lift chains are used for long reliable service life. Large diameter lift cylinders provide smooth operation. ISO / FEM / Class II and III fork carriages are available.

A range of mast types are available: TL offers maximum visibility through the mast by eliminating the inner free lift cylinder. TT offers maximum flexibility with full free lift capability. The Quad mast offers lowest collapsed heights.

**Hydraulics**

Premium control valve provides precise speed control of lift, tilt and accessory functions. Pressure compensation provides repeatable function speed regardless of load condition and improves overall efficiency.

Hydraulic lever actuation is minimal, reducing stress and fatigue. Tilt compensator for stepless operation prevents tilt from jerky movements or speed change when performing simultaneous functions. Crown lift/tilt interlock system provides extended forward tilt at low fork heights and reduced forward tilt at elevated heights to improve truck stability.

The control valves’ modular design allows easy addition of accessory functions. Maximum lowering speed is limited by pressure compensating flow control valve and velocity fuses. Integrated hydraulic cylinder cushions soften mast staging.

All lift cylinder rams are plated and retract into the hydraulic oil for additional corrosion protection when forks are lowered. The steel oil reservoir is integral to the frame to reduce hydraulic oil temperature. This clean, leak-free design includes suction strainer with separate, easily accessible fill port and dipstick with filtered breathers. Oil is returned through a replaceable spin-on type oil filter.

**Batteries**

Battery deck lid releases easily to expose battery for lift out or side battery removal. Optional battery rollers for use with mechanised extraction equipment. A low battery side retainer is standard. Full battery side doors are optional.

**Safety Regulations**

Conforms to European safety standards. Dimensions and performance data given may vary due to manufacturing tolerances. Performance is based on an average size vehicle and is affected by weight, condition of truck, how it is equipped and the conditions of the operating area. Crown products and specifications are subject to change without notice.

