



www.dieci.com

Dieci S.r.l. - Via E. Majorana, 2-4 - Montecchio Emilia (RE) ITALY
Tel. +39 0522 869611 - Fax +39 0522 869798 - E-mail: info@dieci.com

DIECI



407 **DS**



389 **DS**



407 **VS**



389 **VS**

AGRI PLUS

PERFORMANCE	40.7 VS	40.7 PS	38.9 VS	38.9 PS
Maximum capacity (kg)	4.000	4.000	3.800	3.800
Maximum lifting height (m)	7,00	7,00	9,00	9,00
Maximum horizontal outreach (m)	3,90	3,90	5,85	5,85
Outreach at maximum height (m)	0,15	0,15	0,65	0,65
fork swivel angle	146°	146°	146°	146°
Pull-out force (daN)	6.000	6.000	6.000	6.000
Towing force (daN)	8.200	8.200	8.200	8.200
Maximum climb angle	60%	60%	60%	60%
Total weight when empty (kg)	7.700	7.700	7.900	7.900
Max speed (km/h) (referring to wheels with the maximum allowable diameter)	40	40	40	40

BOOM	40.7 VS	40.7 PS	38.9 VS	38.9 PS
Times: when empty (in seconds)				
Lifting	6,6	7,5	6,6	7,5
Descending	3,9	4,4	3,9	4,4
Extension	5,5	6,2	5,5	6,2
Retraction	3,3	3,8	3,3	3,8
Forward swivel	2,1	2,4	2,1	2,4
Backward swivel	1,2	1,4	1,3	1,5
Additional standard speed				

ENGINE	VS Alternative 1	VS Alternative 2	PS
Model:	FPT	FPT	FPT
Rated power kW (hp) @ 2200 rpm	96 (130)	103 (140)	81 (110)
Peak power kW (hp) @ 1900 rpm	105 (141)	113 (152)	89 (120)
Revolutions per minute (rpm):	2200	2200	2200
Operation:	4-stroke diesel		
Injection:	Electronic direct, Common Rail		
Number and arrangement of cylinders:	4, vertical in line		
Engine size (cm³):	4500	4500	4500
Specific consumption - (g/kWh) @ 1900 rpm	208	208	210
Anti-pollution regulation:	Stage 3B / Tier 4i		
	Aftercooler turbo compressor		
	Liquid cooling system		

HYDRAULIC SYSTEM	
Gear pump with max speed capacity (l/min):	VS 210 PS 180
Max operating pressure (bar):	240
Distributor control with joystick:	4 in 1 Electro-proportional

DIFFERENTIAL AXLES
Steering axles: 2, with planetary reduction gears
Steering types: 4-wheel / transversal / 2-wheel
Front axle: fixed
Rear axle: oscillating
Oil bath service braking on the 4 wheels and servo brake
Negative action parking brake

REFUELLING (Litres)	
Hydraulic system (total)	160
Diesel tank	180
AdBlue tank	35

TYRES	
Tyres	405/70x24"
Alternative	445/70R24"
Alternative	17.5LR24"
Alternative	18-22.5"
Alternative	18R22.5"

TRANSMISSION (for VS models)
Vario System EVO 2 hydrostatic transmission.
Electric-hydraulic gear inversion.
Drive Mode: Automotive / Loader / Creeper / Eco.
Electronic inching pedal.

TRANSMISSION (for PS models)
Torque converter transmission.
Electrical-hydraulic reversing gear.
6 forward gears / 3 reverse gears.

STANDARD DEVICES
Anti-tipping device with hazardous movement block.
Hydraulic socket for any accessories on the boom head.
Approved ROPS-FOPS closed, soundproof cab with heating.
Self-blocking front axle differential (limited slip 45%).
Electric steering control.
High efficiency filter with cyclones.
Electric window winder.
Colour LCD display, Grid Heater

TOWING CAPACITY (on request)	
Trailer without brakes (t):	6
Inertia braking (t):	9
Mechanical braking (t):	6
Hydraulic/pneumatic braking (t):	20

DIMENSIONS	40.7 VS	40.7 PS	38.9 VS	38.9 PS
A	360	360	360	360
B	1475	1475	1475	1475
C	2750	2750	2750	2750
D	850	850	850	850
E	4175	4175	4175	4175
F	5075	5075	5075	5075
G	940	940	940	940
H	2445	2445	2445	2445
I	1820	1820	1820	1820
L	2260	2260	2260	2260
M	4910	4910	5045	5045
N	1320	1320	1320	1320
O	3920	3920	3920	3920

Measurements expressed in millimetres The measurements refer to vehicles equipped with 405-70-24" tyres

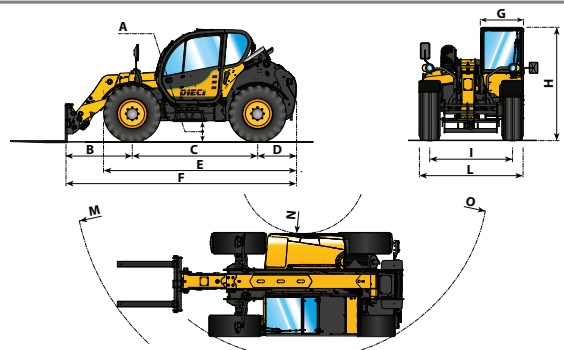

The measurements refer to the vehicle equipped with 405-70-24" tyres

