

# ATLAS

## RAIL-ROAD EXCAVATORS

FROM 17 TO 23 TONS



**SAFE. POWERFUL. RELIABLE.**

[WWW.ATLASGMBH.COM](http://WWW.ATLASGMBH.COM)

**ATLAS**

# **ATLAS – CONSTRUCTION MACHINERY MANUFACTURER WITH TRADITION**

## **From person to person**

When Hinrich Weyhausen started selling construction and agricultural machinery in 1919 he discovered that the machines that his customers actually needed were not available. So he listened to them carefully and went about building the machines himself – exactly according to the requirements of the people who used his machines every day. He carried out pioneering work with a passion under the brand name of Atlas. His focus was always on the benefit of the machines. And nothing has changed for us in terms of this ideal today.



**Atlas will make you strong  
with excellent products and  
a comprehensive service.**

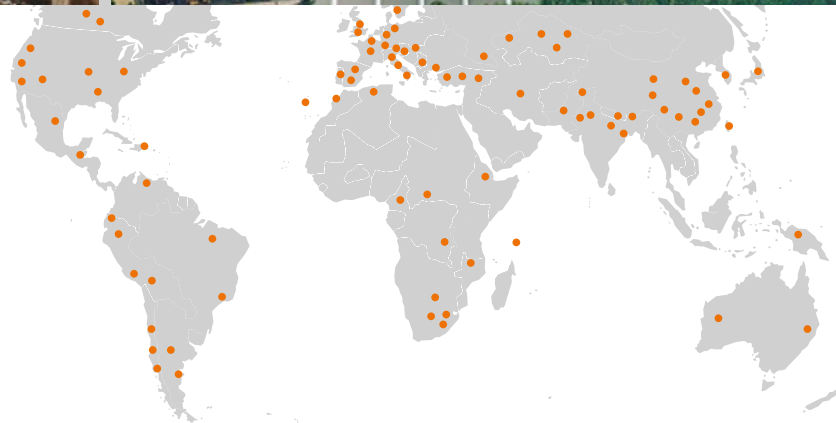

With highly motivated employees, a great deal of commitment and expertise ATLAS Maschinen GmbH develop successful crane & excavator technologies. Numerous customers, engineers and experts all around the globe have made their contribution. The result is robust equipment to enable you to work more effectively and safer than ever before.

As our know-how grew, so too did our dealer and service network worldwide.

We can hence guarantee – in those days and today too – that we will always be on the spot when you need us.





Atlas manufactures a wide range of equipment for the construction, railroad, material handling and infrastructure industries. You will find more information on Atlas under [www.atlasgmbh.com](http://www.atlasgmbh.com).

## CONSTRUCTION



## TRANSPORT



## INFRASTRUCTURE



## RECYCLING



# CUSTOMER SATISFACTION IS OUR PRIORITY!

## WE ARE COMMITTED

to providing our customers with highest quality products and services.

## QUALITY STANDARDS AND CUSTOMER SATISFACTION

are measured in terms of service performance, reliability, relevance and timeliness.

## OUR COMPANY'S MISSION, GOALS AND OBJECTIVES

are directed towards ongoing process improvement as a basis for strengthening our competitive position and for improving product quality and service standards.

## QUALITY STANDARDS AND CUSTOMER SATISFACTION

will be measured in terms of product performance and reliability.

# SAFE. POWERFUL. RELIABLE.

**Building on technology –  
High-tech excavator for use on rails.**

ATLAS rail-road excavators were especially developed for use on rails and combine optimum mobile excavator technology with the most up-to-date know-how for rail use. This is your guarantee for top performance, even with difficult track conditions. We were the first to put an excavator on rails in 1965.

We were market and technology leaders in this field back then and still are today. As the sole world-wide supplier, we offer the computer assisted rail contact pressure system (CARSY).

We are the sole manufacturer in Europe of rail-road, short tailswing excavators with a swing radius of less than 2000 mm in combination with the approval of German Federal Railways. We can offer any chassis configuration to fit any rail network for our world-wide customers.





**THE RIGHT  
CHOICE  
EVERY TIME**



As option available:  
Hydrostatic Drive at 1604 ZW  
with track width 1000 / 1435 mm  
track width. Perfect setting for  
permanent - brake controlled -  
high ride drive on tracks  
to prevent damage and  
excessive wear of the tyres.



As option available:  
Friction Drive System available  
for 1404 ZW with track width  
1000, 1435 and 1524 mm.



CARSY System available for  
1404 / 1604 ZW with track  
width 1435 / 1524 and  
1600 mm.

We offer rail-road excavators of three types. In particular, the excavators comply with the latest construction requirements of the German Federal Railways.

1404 ZW with the CARSY-System	1404 Friction wheel	1604 ZW with the CARSY-System
17 - 20 t	17 - 19 t	21 - 23 t
95 kW (130 HP)	95 kW (130 HP)	115 kW (157 HP)
Tailswing: 1575, 1700 mm	Tailswing: 1575, 1700 mm	Tailswing: 1750, 1950 mm

**ATLAS - CONSTRUCTION  
MACHINERY MANUFACTURER  
WITH TRADITION**

Take advantage of our many years of know-how and experience for your application: on rail, alongside the track and mounted on the railway wagon.



## ATLAS SERIES

# UNCOMPROMISINGLY BUILT FOR HIGH PERFORMANCE

Atlas builds its wheeled excavators especially for the hardest construction sites. The result is the robust machines to withstand the worst possible working conditions.

High-strength materials, high productivity and cost-effectiveness - save time and money for future.

**New quieter exhaust** system covering new Euro 4 STAGE / US EPA TIER 4 emission standards with a sealed diesel particle filter.

New Tier 4 engines - lower exhaust emissions.



New attractive counterweight design and better weight distribution.



Always secured - new camera system with 5/6' interior monitor.



New "LED" rear lights for better visibility and safety.





Intelligent hydraulics for more productivity and perfect controls. Load-independent overlapping of working motions.



Standard air-climate control system.



Improved air intake to optimize engine's work.



Particularly effective boom design - extremely light and enormously robust booms.

Ideal weight distribution, fatigue-free work and fast turnover.

Functional and spacious cab design adapted to your needs.

# THE RAIL-ROAD EXCAVATOR

# A PLEASURE IN OPERATION

**Safety, power and fast and comfortable operation set our rail-road excavator apart, making it amongst the most pleasurable machines to operate on rail or on site.**

## **SPEED – WORKING FASTER THAN EVER**

- The required pressures on the rail guidance wheels are automatically set when the 1404 ZW and 1604 ZW are re-railed. No awkward external adjusting screw to set the contact pressure on the tyres.
- Innovative AWE 4 technology for sensitive, proportional control of all movements irrespective of load. Travel and work simultaneously. This is the big advantage to you.
- Front and rear wheels can be controlled independently (not with the friction wheel version).
- Simple de- and re-railing ensure high operating comfort for fast, safe and efficient operation.

## **TRACTIVE FORCE**

- Faster on the construction site: the enormous power allows you to use our rail-road excavator as a “shunting locomotive”. Both models are approved for 40 T un-braked trailer weight and 120 T braked trailer weight. We can also supply with a wagon brake on request.

## **PRECISE OPERATION – OPTIMISED FOR THE TRACK**

- 4 outrigger stabilizers (with the 1604 chassis) adapt optimally to the rail embankment.
- Customized specification: tailor your excavator precisely to your requirements from the various superstructures and chassis, for example the superstructure of the 1404 ZW can be mounted on the chassis of the 1604 ZW for maximum stability with ultra short tailswing.
- Counterweights suitable for the application can be rapidly changed.
- The loading gauge for wagons is met.







## A SPACE-SAVER – GREAT WHEN IT GETS TIGHT

- Rail-road excavator with ultra short tailswing. Choose between the different counterweight options.
- The 1404 ZW features the shortest tailswing on the market at 1575 mm making it suitable without restriction for any spacings between rail tracks.
- For narrow gauge tracks, use the 1404 ZW rail-road excavator friction wheel with its up to 1000mm narrow axles.



## RELIABLE – BECAUSE EVERY MINUTE COUNTS

Our market leadership is based on our well-proven technology tried and tested a thousand times over in the most arduous applications. High-tensile steels, robust electric and electronic components as well as excellent workmanship in all hydraulic components ensure that the excavator is the reliable heart on any construction site.



# YOU WORK, WE PROTECT

# THOROUGHLY DESIGNED

## STABILITY

- Low centre of gravity ensures optimum stability in operation. Assisted by a transverse mounted engine.

## SAFE ON RAILS

- The outriggers are automatically lifted when the “drive” function is selected. This avoids damage during rail operation.
- Continuous monitoring of contact pressure. (not friction wheel version)
- The air reservoirs of the wagon brake are located in the superstructure and chassis and are very well protected.
- De-railing of the bogie by the outriggers is automatically eliminated.







## ELECTRONIC SWING AND HEIGHT LIMITATION

- Computer assisted swing limitation, which proportionally reduces the superstructure speed electronically when the limit is reached.
- Electronic height limitation eliminates the risk of the excavator boom from coming into contact with obstacles above such as power cables. The maximum articulating boom height, relative to the point of reference, is taken into account. The system recognizes whether the clamshell or bucket are fitted and adjusts the programmed operating height accordingly. The motion stops when the programmed limit is reached.
- Swing and height limitation can be comfortably programmed from the operator's seat. It is not necessary to get out of the machine.

## EMERGENCY DERAILING

- Emergency de-railing is permanently available and doubly protected. Firstly by connecting the hydraulics to the cigarette lighter via an electric cable. Secondly by a fixed emergency hydraulic hand-pump.
- An electric emergency pump is available as an option.
- Emergency lowering of the rail bogie is permanently available.



## SUPERSTRUCTURE - HIGHLIGHTS. ENGINE.

# POWER



Deutz turbo-charged engines provide fast and powerful motions, a powerful drive train, fast cycle times and dynamic development in performance.

### 1. GOOD FOR THE ENVIRONMENT

- DEUTZ TCD 4.1 L4 - The new engines meet the EU Stage IV/ US EPA Tier 4 emissions standards.
- Engines benefits from an exhaust-gas after treatment system with a sealed diesel particulate filter and regeneration achieved either by combustion or controlled air throttling

### 2. GOOD FOR YOUR WORK:

- Fuel savings of up to and even above 5 percent compared with Tier 3
- Lower emissions – better performance
- Compact design and enormous power density at very low engine speeds
- Long service life
- Turbo charged with intercooler

### 3. GOOD FOR YOUR COMFORT AND FOR YOUR NERVES

- Particularly quiet engine
- Low maintenance costs, easily accessible maintenance points and little need for servicing
- A large selection of replacements parts allows fast and inexpensive service
- Engine controller that supplies the display with operating and service data

### OPTIONS:

- Automatic idle running. When the excavator is not working or moving the engine speed automatically reduces and fuel consumption is lowered.

## HYDRAULIC SYSTEM by *Linde*

# PRECISION CONTROL

- The rail-road excavators are fitted with well-proven load-sensing hydraulics. Our intelligent AWE 4 hydraulic management system allows simultaneous movements to be carried out irrespective of load. For more productivity and safe operations.
- The power you need, at the right time. For fast cycles or high lifting capacity: our load-sensing system attunes the method of operation of the excavator exactly to your application. For greater economy – you save fuel and maintenance costs.

### WHAT YOU SHOULD ALSO KNOW

- Primary and secondary overload protection.
- Suction valves for all operating functions.
- Overload lock valves, precision lowering valves and travel brake valve.
- **Pipe break protection valves for lifting and articulated cylinders**  
**Optionally also on adjusting and articulating cylinders.**
- Emergency steering and pressure reservoir for emergency lowering of the boom system.
- Proportional control of attachments by slider in joystick in the 1604ZW as standard.





## CAB

# FAR-SIGHTEDNESS

Our roomy two-man cab is the largest on the market and provides everything you need to work comfortably and efficiently.

### THE CAB WITH MORE VIEW

- Two-man cab with excellent all-round vision.
- Optimum lay-out of the controls provides clear view of the attachment.
- Optional: rear view monitoring with camera and display.

### WELCOME TO THE “FEEL-GOOD” WORKPLACE

- The cab is very well isolated from vibrations.
- The sound pressure level is very low thanks to the high quality sound insulation.
- Air conditioning is standard including a defrosting function for fast demisting and de-icing of the windscreen.
- The air-cushioned operator's seat is individually adjustable in all movements. Backrest, lumbar support, cushion length and angle can all be easily adjusted.
- The narrow steering column gives excellent vision to the attachment and the rail bogie.

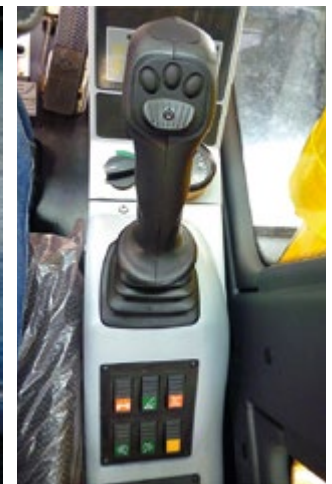



## CHASSIS – HIGHLIGHTS

# GUIDANCE FORCE

Numerous components ensure safe and strong contact between chassis and rail.

## GO INTO (RAIL) GUIDANCE MODE

Our **CARSY system (Computer assisted rail contact pressure system)** electronically ensures the optimum pressure on the rail is maintained continuously and automatically.

- The required pressures are automatically set, continuously monitored and adjusted if necessary.
- The front and rear bogie wheels can be independently switched to permit simple re-railing and de-railing and positive by-passing of rail points.
- Automatic self-diagnostics of the electronics.
- Available for 1404 ZW and 1604 ZW models.

## OPERATION AT THE OPTIMUM LEVEL

- Continuous self-leveling of the rail running gear ensures smooth movement of the rail-road excavator when travelling on rail.

## OPTIMUM GRIP

- Bogie axle box with optimum oscillation in the axle mountings. The successful result: safe operation especially on uneven construction site tracks and in cornering.
- With the friction wheel model, traction is provided via a non-slip friction roller.







## STABLE

The low centre of gravity and our compact design guarantee high stability with excellent off-road mobility. 1604ZW also has a bilateral barrier on the track wheel cylinder at a swing of 5° from the longitudinal axis and at a standstill.

## FIRST CHOICE

The right chassis for any application: with or without outriggers with different track gauges and different wheelbases.

## DRIVING POWER

Whether in crawling speed or top speed – the high torque drives the excavator quickly and safely through any terrain, assisted by the well-proven traction characteristics of our tires. The sensitive power assisted steering on the oscillating axle transforms any rough terrain into a “straight road”. Even at high-speed road travel, the TIER 4 series impresses through its road holding and thereby provides excellent handling characteristics. Further, 1604ZW has a traction increase at the push of a button that if needed increases the contact pressure of the drive wheels on the track by about 20%. The so-optimized driving leads to improved load starting.

The chassis incorporates robust, specially designed excavator axles with planetary drives in all 4 wheel hubs. All-wheel drive, a variable displacement motor (1604ZW with power shift transmission) and a double-action brake-valve are standard.

## RELIABILITY – HERE WE ARE PLAYING IT SAFE

- Tie-down lugs for fast and safe securing of the excavator for transport on rail or road.
- Steering axle with automatic oscillation lockout to allow travel with heavy loads in any terrain. Activation of the lockout either automatically when braking or manually.

## OTHER SAFETY ASPECTS

- Brakes: wet, maintenance-free multi-disc brake
- Excellent emergency steering characteristics



# TECHNICAL SPECIFICATION SHEET

## RAIL-ROAD EXCAVATOR 1404ZW

### Main dimensions

Base machine A41.5 – with 4 outriggers

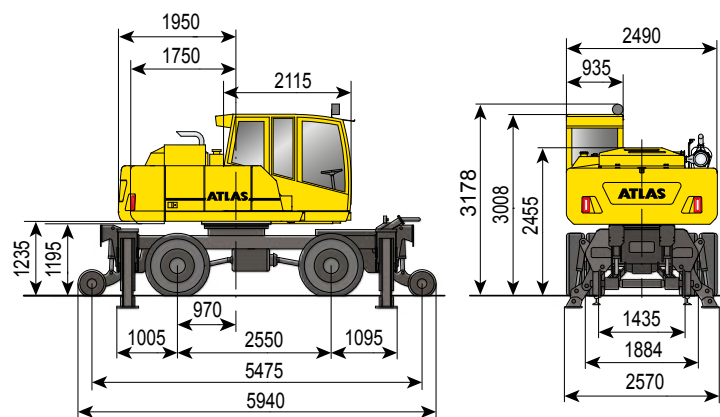

### Travel configuration with grab

Base machine A41.4 – without outriggers

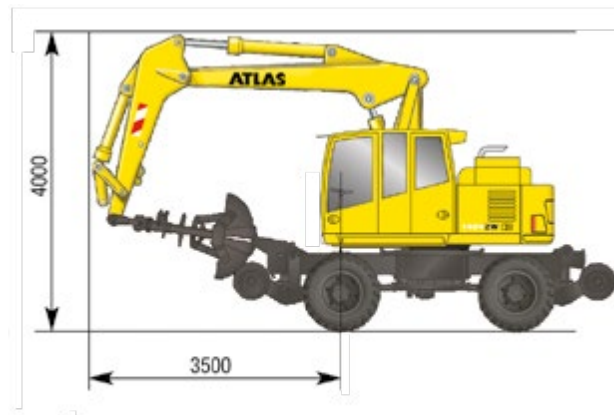

### Working equipment:

#### Base machine

Code	Description	Weight/kg
A41.4	Rail-Road hydraulic excavator 1404 ZW, without outriggers, tailswing 1575 mm	13600
A41.5	Rail-Road hydraulic excavator 1404 ZW, with 4 outriggers, tailswing 1575 mm	16000

#### Weight/kg

#### Standard equipment

- Maintenance point for filtration system
- Hydraulic system for grab and grab rotation function
- Tank indicator
- Battery main switch in negative lead.
- "Travel" function via foot control
- Accumulator for emergency lowering of boom system
- Sliding window in cab door
- Windshield washer system
- Central lubrication
- Tilt and height adjustable steering column
- Radio pre-installation
- Storage box in the cab

#### Additional and special equipment

Code	Description	Weight/kg
B41.20	Heavy counterweight (4.9 t), tailswing 1700 mm	400
B41.20	Heavy counterweight (5.3 t), tailswing 1700 mm	800
B41.39	Additional hydraulic unit for variable boom cylinder	20
B41.23	Two man fully glazed cab	300

#### Base section of arm and boom

Code	Description	Weight/kg
C53.41P	Base arm with two lift cylinders and an internally mounted operating cylinder	1090
C53.46	Boom with articulating cylinder only for base arm C53.41P	930

#### Sticks

Code	Description	Weight/kg
D41.22	Rail-road excavator stick, working length 2200 mm	490

#### Bucket tipping cylinder

Code	Description	Weight/kg
F53.1	Bucket tipping cylinder with reversing linkage	165

#### Rail guidance

CARSY (Computer assisted rail contact pressure system). Automatic system for regulating and monitoring the force of the rail guide wheels. The required pressures are automatically set, continuously monitored and adjusted if necessary. Depending on the pre-selected operating condition, each separate guidance bogie wheel is set to a different pressure in accordance with a prescribed schedule, locked or hydraulically trailed.

- Comfort seat with armrests and lumbar support
- Toolbox on chassis
- Sealed pivot points in the base section of the boom
- Boom and stick with 50 hour maintenance intervals
- Securing lug for securing the grab during road travel
- Air-conditioning
- Air dryer for compressed air system
- Narrow axles for underground and suburban railways

The front and rear bogie wheels can be independently switched to permit simple de-railing and positive crossing of rail points.

Automatic self-diagnosis of the electronic system. Emergency function: de-railing is assured even in the event of a fault or complete breakdown.

Track gauge 1435 mm, other widths on request.



# TECHNICAL SPECIFICATION SHEET

## RAIL-ROAD EXCAVATOR 1404ZW

### Engine

Power rating acc. to ISO 1585	95 kW (130 HP)
Manufacturer	Deutz
Type	TCD 4.1 (Stage Tier 3B)
Displacement	4000 cm <sup>3</sup>
Rotational speed	1800 rpm
Design	Turbocharger/charge-air cooling

### Hydraulic system

Computer controlled AWE4 system with a load limiting high performance piston pump and fuel efficient on-demand power control for sensitive, proportional and load independent ramp-up of all operational movements • Primary and secondary protection of the hydraulic system against overload • Suction valve for all operational functions as well as restrictors in the lift and articulating circuits • Fine lowering and load-retaining valve in the lifting circuit.

Hydraulic system	1 x AKP
Main pump	HPR 135
Max. flow variable capacity pump	300 l/min
Max. operating pressure for operating movements	340 bar

### Noise level

Noise level\* is significantly below EC limits

Ambience level (L <sub>WA</sub> )	98 dB (A)
Cab level (L <sub>PA</sub> )	73 dB (A)

\*Dynamic sound level measurement according to 2000/14 EC

### Electrical system

Operating voltage	24 Volt
Cold-start heavy duty battery	2 x 100 Ah
Electrical system in compliance with StVZO (Regulations Authorizing the Use of Vehicles for Road Traffic in Germany) and European standard	

### Brakes

Service brake	pneumatic-hydraulically actuated drum brake
Parking brake	pneumatically-operated spring-loaded parking brake

Emergency brake for use on rail	
Max. un-braked trailer load	40 t
Max. trailer load with wagon brake	120 t

### Fluid capacities

Fuel tank	190 l
Hydraulic tank	200 l
Engine oil	10 l

### Cab

Flexibly mounted • Heat absorbing extra wide windscreen for all-round vision • Glare-free interior • Ergonomic pilot control levers • Adjustable steering column • Lengthways adjustment of the seat independent of the control console • Front windscreen slidable under the cab roof • Second seat for mate

Type	Atlas 935 two-man comfort cab	
Overall length	2130 mm	
Width	935 mm	

### Swing assembly

Swing motor	axial piston motor with priority valve
Swing gear	planetary reduction
Swing brake*	multi-disc brake

Drive via an internally toothed swing bearing	
Swing speed	8.5 rpm
Swing torque	37.5 kNm

\* simple swinging on slopes against the incline is assured, with locking foot pedal when slewing pressure of 120 bar is exceeded.

### Power Transmission

40 t special excavator axles with planetary drives to all four wheel hubs

- All-wheel drive • Variable drive engine • Double acting travel brake valve
- Travel direction selector with steering column mounted lever or switch on pilot control lever • Steering axle with automatic oscillation lock
- Travel controls via foot pedal valve

### Travel speed

Road and rail operation	
Creep speed	max. 1.0 km/hour
Off-road speed	max. 5.0 km/hour
Highway speed	max. 20 km/hour
Rail guidance, track gauge 1435 mm, other widths on request	

### Tires

8 x	10.00 - 20
(inner tire - highway, outer tire - off highway tread pattern)	

### Weight

Operating weight	17.0 - 20.0 t
------------------	---------------



# TECHNICAL SPECIFICATION SHEET

## RAIL-ROAD EXCAVATOR 1404ZW

### Working range grab

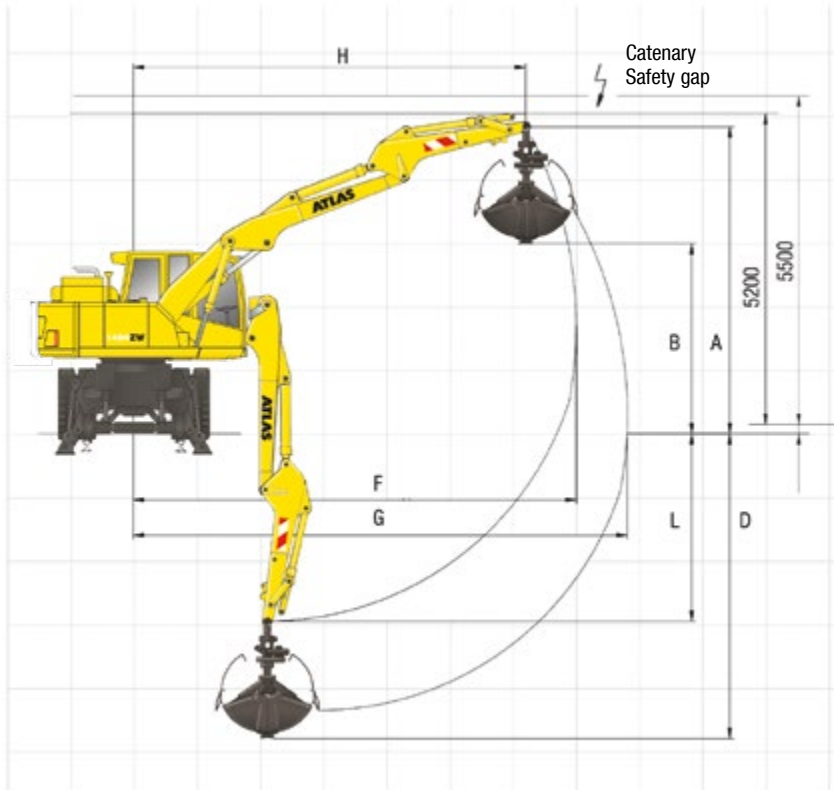

#### Stick D41.22, working length 2200 mm

Equipment: A41.5, C53.41P, C53.46, D41.22, F31, E332, E344

			Grab
A	Height of stick	mm	4980
B	Discharge height	mm	3020
D	Max digging depth	mm	5170
F	Max. radius	mm	7400
G	Max. reach	mm	8250
H	Max. arm position	mm	6605
J	Max. reach height	mm	–
L	Bucket pivot point	mm	3205
	Grab	l	350
	Grab clamping force	kN	73.0
	Operating weight	t	19.3

### Working range bucket

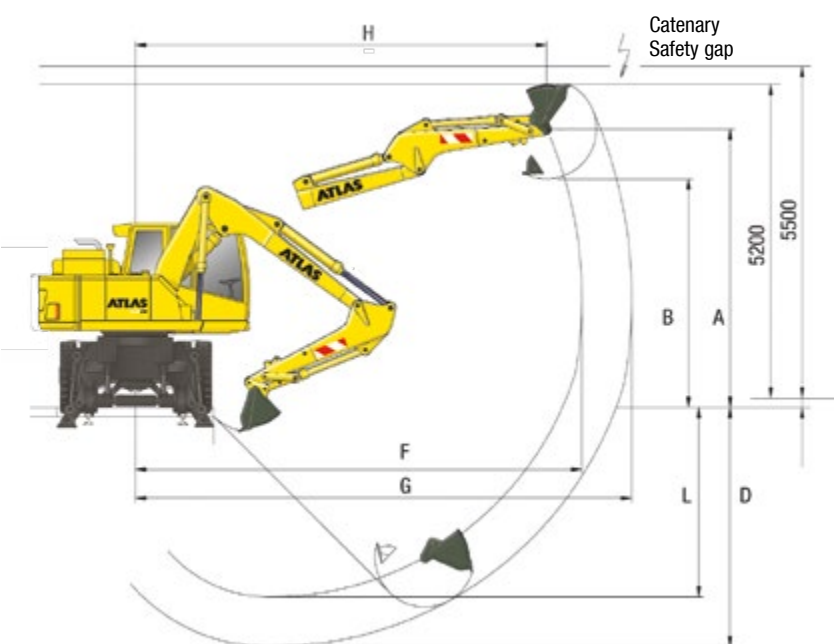

#### Stick D41.22, working length 2200 mm

Equipment: A41.5, C53.41P, C53.46, D41.22, F53.1, G649

			Bucket
A	Height of stick	mm	4465
B	Discharge height	mm	3715
D	Max digging depth	mm	4300
F	Max. radius	mm	7400
G	Max. reach	mm	8495
H	Max. arm position	mm	6850
J	Max. reach height	mm	5200
L	Bucket pivot point	mm	3205
	Bucket	l	700
	Stick digging force	kN	82
	Bucket digging force	kN	130
	Operating weight	t	19.0



# TECHNICAL SPECIFICATION SHEET

## RAIL-ROAD EXCAVATOR 1404ZW

Base machine A41.5, C53.41P, C53.46, D41.22

### Tailswing 1700 mm (4.9 t) 4 outriggers

Hook height m	3.0 m		4.0 m		5.0 m		6.0 m		7.0 m		
	F	L	F	L	F	L	F	L	F	L	
	5	a	–	–	5.3	5.3	5.4	4.6	4.9	3.4	–
	b	–	–	5.3	4.0	5.4	2.9	4.9	2.2	–	–
4	a	–	–	6.6	6.3	5.6	4.6	4.9	3.5	3.8	2.6
	b	–	–	6.6	3.9	5.6	2.9	4.9	2.2	3.8	1.6
3	a	–	–	7.5	6.1	6.0	4.5	5.1	3.5	4.6	2.6
	b	–	–	7.5	3.8	6.0	2.8	5.1	2.2	4.6	1.6
1	a	10.5	8.6	8.5	6.1	6.6	4.4	5.4	3.3	4.6	2.6
	b	10.5	4.9	8.5	3.7	6.6	2.8	5.4	2.1	4.6	1.5
0	a	11.6	8.4	8.5	5.9	6.6	4.3	5.4	3.2	4.2	2.5
	b	11.6	4.6	8.5	3.6	6.6	2.8	5.4	2.0	4.2	1.5
-1	a	12.1	8.2	8.6	5.8	6.7	4.2	5.4	3.2	–	–
	b	12.1	4.5	8.6	3.4	6.7	2.6	5.4	1.9	–	–
-2	a	12.4	8.1	8.9	5.7	6.6	4.1	–	–	–	–
	b	12.4	4.4	8.9	3.4	6.6	2.4	–	–	–	–

### Tailswing 1700 mm (4.9 t) no outriggers

Hook height m	3.0 m		4.0 m		5.0 m		6.0 m		7.0 m		
	F	L	F	L	F	L	F	L	F	L	
	5	a	–	–	5.3	4.7	5.4	3.4	4.2	2.5	–
	b	–	–	5.3	3.6	5.4	2.6	4.9	1.9	–	–
4	a	–	–	6.6	4.6	5.6	3.4	4.3	2.6	3.2	1.9
	b	–	–	6.6	3.5	5.6	2.6	4.9	1.9	3.8	1.4
3	a	–	–	7.5	4.5	5.5	3.3	4.3	2.5	3.2	1.9
	b	–	–	7.5	3.4	6.0	2.5	5.1	1.9	4.6	1.4
1	a	10.5	6.7	7.6	4.4	5.5	3.3	4.1	2.4	3.1	1.8
	b	10.5	4.8	8.5	3.3	6.6	2.4	5.4	1.8	4.6	1.3
0	a	11.6	6.4	7.7	4.3	5.4	3.1	4.0	2.3	3.1	1.8
	b	11.6	4.6	8.5	3.1	6.6	2.3	5.4	1.7	4.2	1.3
-1	a	12.1	6.2	7.7	4.1	5.3	3.0	3.9	2.3	–	–
	b	12.1	4.4	8.6	3.0	6.7	2.2	5.4	1.6	–	–
-2	a	12.4	6.1	7.6	4.1	5.2	2.9	–	–	–	–
	b	12.4	4.3	8.9	3.0	6.6	2.1	–	–	–	–

### Tailswing 1575 mm (4.5 t) no outriggers

Hook height m	3.0 m		4.0 m		5.0 m		6.0 m		7.0 m		
	F	L	F	L	F	L	F	L	F	L	
	5	a	–	–	5.3	5.3	5.4	5.0	4.9	3.8	–
	b	–	–	5.3	4.4	5.4	3.2	4.9	2.4	–	–
4	a	–	–	6.6	6.6	5.6	4.9	4.9	3.8	3.8	2.9
	b	–	–	6.6	4.3	5.6	3.2	4.9	2.5	3.8	1.8
3	a	–	–	7.5	6.6	6.0	4.9	5.1	3.8	4.6	2.9
	b	–	–	7.5	4.2	6.0	3.2	5.1	2.4	4.6	1.8
1	a	10.5	9.9	8.5	6.5	6.6	4.8	5.4	3.7	4.6	2.8
	b	10.5	6.0	8.5	4.1	6.6	3.1	5.4	2.3	4.6	1.8
0	a	11.6	9.9	8.5	6.5	6.6	4.7	5.4	3.6	4.2	2.8
	b	11.6	5.8	8.5	4.0	6.6	3.0	5.4	2.2	4.2	1.7
-1	a	12.1	9.7	8.6	6.3	6.7	4.6	5.4	3.5	–	–
	b	12.1	5.6	8.6	3.9	6.7	2.9	5.4	2.2	–	–
-2	a	12.4	9.7	8.9	6.3	6.6	4.5	–	–	–	–
	b	12.4	5.6	8.9	3.8	6.6	2.8	–	–	–	–

### Tailswing 1700 mm (5.3 t) no outriggers

Hook height m	3.0 m		4.0 m		5.0 m		6.0 m		7.0 m		
	F	L	F	L	F	L	F	L	F	L	
	5	a	–	–	5.3	5.2	5.4	3.8	4.6	2.8	–
	b	–	–	5.3	4.0	5.4	2.9	4.9	2.2	–	–
4	a	–	–	6.6	5.1	5.6	3.7	4.6	2.9	3.5	2.1
	b	–	–	6.6	3.9	5.6	2.9	4.9	2.2	3.8	1.6
3	a	–	–	7.5	5.0	5.9	3.7	4.6	2.8	3.5	2.1
	b	–	–	7.5	3.8	6.0	2.8	5.1	2.2	4.6	1.6
1	a	10.5	7.4	8.2	4.9	5.9	3.6	4.5	2.7	3.5	2.1
	b	10.5	5.4	8.5	3.7	6.6	2.8	5.4	2.1	4.6	1.5
0	a	11.6	7.1	8.2	4.8	6.0	3.5	4.4	2.6	3.4	2.0
	b	11.6	5.2	8.5	3.6	6.6	2.7	5.4	2.0	4.2	1.5
-1	a	12.1	6.9	8.3	4.6	5.9	3.4	4.3	2.0	–	–
	b	12.1	5.0	8.6	3.4	6.7	2.6	5.4	1.9	–	–
-2	a	12.4	6.9	8.3	4.6	5.7	3.3	–	–	–	–
	b	12.4	5.0	8.9	3.4	6.6	2.5	–	–	–	–

a = travel on road permitted, b = travel on rail permitted, L = Lateral, F = Front

All values in tonnes (t) were determined acc. to ISO 10567 and include a stability factor of 1.33 or 87% of the hydraulic lifting capacity. These values are applicable at the top of the arm with optimum positioning of the corresponding boom system.

### Operating weights, tailswing

Type	Configuration	Operating weight with boom adjusting mechanism	Tailswing mm
1404 ZW	A41.4	17100 kg	1575
1404 ZW	A41.4	17500 kg	1700 (4.9 t)
1404 ZW	A41.4	17900 kg	1700 (5.3 t)
1404 ZW, 4 outriggers	A41.5	19500 kg	1575
1404 ZW, 4 outriggers	A41.5	19900 kg	1700 (4.9 t)
1404 ZW, 4 outriggers	A41.5		

#### Approvals

The equipment marked \* is an essential requirement of the German Federal Railways for operation on their network.

The safety testing is conducted by the health and safety executive (Berufsgenossenschaft), compliance with the appropriate regulations is verified by the German Federal Railways and the TÜV.

### Additional and special equipment

- Short tailswing version (1575, 1700 (4.9 t), 1700 (5.3 t) tailswing (mm))\*
- Two-man cab\*
- Auxiliary heating
- Narrow axles for underground and suburban railways
- Combined check point for ease of filter maintenance
- Hose-rupture safety device for lifting operation, overload warning device\*
- Trailer hitch on chassis\*
- Emergency manual hydraulic pump\*
- Special tow bar\*
- German Federal Railways approved lights\*
- Lift limitation electronically adjustable from the cab\*
- Swing limitation adjustable from the cab\*
- Wagon brake unit with footplate brake valve, permitted trailer load is 120 t
- Factory Federal German Railways approval with appropriate certification and all necessary accessories: fire extinguisher, first aid kit, earth cable, red/white flag, torch with red dimmable light, loud hailer, digital speed measurement instrument, oil spill tarpaulin and oil binder\*
- Rotating beacons
- Working floodlight(s)
- Radio/CD/MP3, front AUX in, USB
- Refueling pump
- Rail bogie with track gauges of up to approx. 1600 mm
- TÜV-approval

Items marked with \* are a requirement for Federal German Railway approval

# TECHNICAL SPECIFICATION SHEET RAIL-ROAD EXCAVATOR / FRICTION WHEEL 1404ZW

## Main dimensions

Base machine A41.4S

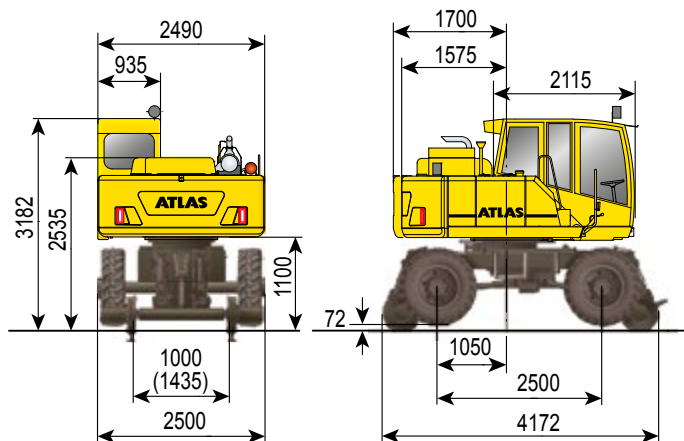

## Travel setup with grab

Base machine A41.4S

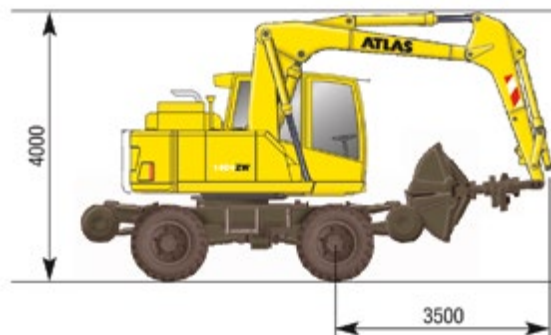

## Working equipment:

Base machine		Weight/kg	Standard equipment
A41.4S	Rail-road hydraulic excavator 1404 ZW, with 1000 mm track gauge, tailswing 1575 mm	13600	<ul style="list-style-type: none"> <li>Maintenance point for filtration system</li> </ul>
<b>Additional and special equipment</b>			<ul style="list-style-type: none"> <li>Hydraulic system for grab and grab rotation function</li> </ul>
B41.20	Heavy counterweight (4.9 t), tailswing 1700 mm	400	<ul style="list-style-type: none"> <li>Tank indicator</li> </ul>
	Heavy counterweight (5.3 t), tailswing 1700 mm	800	<ul style="list-style-type: none"> <li>Battery main switch in negative lead.</li> </ul>
B41.39	Additional hydraulic unit for variable boom cylinder	20	<ul style="list-style-type: none"> <li>"Travel" function via foot control</li> </ul>
B41.23	Two-man fully glazed cab 6032281 Conversion kit 1435 mm track gauge	300	<ul style="list-style-type: none"> <li>Accumulator for emergency lowering of boom system</li> </ul>
<b>Base section of arm and boom</b>			<ul style="list-style-type: none"> <li>Sliding window in cab door.</li> <li>Windshield washer system</li> </ul>
C53.41P	Base arm with two lift cylinders and an internally mounted operating cylinder	1090	
C53.46	Boom with articulating cylinder only for base arm C53.41P	930	<ul style="list-style-type: none"> <li>Central lubrication</li> </ul>
<b>Sticks</b>			<ul style="list-style-type: none"> <li>Tilt and height adjustable steering column</li> </ul>
D41.22	Rail-road excavator stick, working length 2200 mm	490	<ul style="list-style-type: none"> <li>Preparation for radio installation</li> </ul>
<b>Bucket tipping cylinder</b>			<ul style="list-style-type: none"> <li>Storage box in the cab</li> </ul>
F53.1	Bucket tipping cylinder with reversing linkage	165	<ul style="list-style-type: none"> <li>Air-cushioned comfort seat with armrests and lumbar support</li> <li>Toolbox on chassis</li> <li>Sealed pivot points in the base section of the boom</li> <li>Boom and stick with 50 hour maintenance intervals</li> <li>Securing lug for securing the grab during road travel</li> <li>Air-conditioning</li> <li>Air dryer for compressed air system</li> </ul>
<b>Rail guidance</b>			
<p>Four separate rail guidance wheels drive by a friction wheel activated by 4 hydraulic cylinders with appropriate safety equipment. During rail travel the chassis is lifted so rail points (Indusi) are not damaged when crossing. Greater loads can be picked up laterally to the direction of travel by lowering the chassis onto the sleeper heads. All movements can be controlled from the cab. An adapter allows the excavator to work on other track gauges.</p>			



# TECHNICAL SPECIFICATION SHEET RAIL-ROAD EXCAVATOR / FRICTION WHEEL 1404ZW

## Engine

Power rating acc. to ISO 1585	95 kW (130 HP)
Manufacturer	Deutz
Type	TCD 4.1 (Stage Tier 3B)
Displacement	4000 cm <sup>3</sup>
Rotational speed	1800 rpm
Design	Turbocharger/charge-air cooling

## Hydraulic system

Computer controlled AWE4 system with a load limiting high performance piston-pump and fuel efficient on-demand power control for sensitive, proportional and load independent ramp-up of all operational movements • Primary and secondary protection of the hydraulic system against overload • Suction valve for all operational functions as well as restrictors in the lift and articulating circuits • Fine lowering and load-retaining valve in the lifting circuit.

Hydraulic system	1 x AKP
Main pump	HPR 135
Max. flow variable capacity pump	300 l/min
Max. operating pressure for operating movements	340 bar

## Noise level

Noise level\* is significantly below EC limits

Ambience level (L <sub>WA</sub> )	98 dB (A)
Cab level (L <sub>PA</sub> )	73 dB (A)

\*Dynamic sound level measurement according to 2000/14 EC

## Electrical system

Operating voltage	24 Volt
Cold-start heavy duty battery	2 x 100 Ah
Electrical system in compliance with StVZO (Regulations Authorizing the Use of Vehicles for Road Traffic in Germany) and European standard	

## Brakes

Service brake	pneumatic-hydraulically actuated drum brake
Parking brake	pneumatically-operated spring-loaded parking brake

Emergency brake for use on rail

Max. un-braked trailer load	40 t
Max. trailer load with wagon brake	120 t

## Fluid capacities

Fuel tank	190 l
Hydraulic tank	200 l
Engine oil	10 l

## Cab

Flexibly mounted • Heat absorbing extra wide windscreen for all-round vision • Glare-free interior • Ergonomic pilot control levers • Adjustable steering column • Lengthways adjustment of the seat independent of the control console • Front windscreen stowable under the cab roof • Second seat for mate

Type	935 two-man comfort cab
Overall length	2130 mm
Width	935 mm

## Swing assembly

Swing motor	axial piston motor with priority valve
Swing gear	planetary reduction
Swing brake*	multi-disc brake

Drive via an internally toothed swing bearing

Swing speed	8.5 rpm
Swing torque	37.5 kNm

\* simple swinging on slopes against the incline is assured, with locking foot pedal when slewing pressure of 120 bar is exceeded.

## Power Transmission

40 t special excavator axles with planetary drives to all four wheel hubs

- All-wheel drive • Variable drive engine • Double acting travel brake valve
- Travel direction selector with steering column mounted lever or switch on pilot control lever • Steering axle with automatic oscillation lock
- Travel controls via foot pedal valve

## Travel speed

Road and rail operation	Road	Rail
Crawling speed	0 - 1.3 km/hour	0 - 3.5 km/hour
Off-road speed	0 - 5.6 km/hour	0 - 10.9 km/hour
Highway speed	0 - 20 km/hour	0 - 40 km/hour

## Tires

4 x (Tread: Titan)	12.00 - 20
-----------------------	------------

## Weight

Opera	17 - 19t
-------	----------

# TECHNICAL SPECIFICATION SHEET RAIL-ROAD EXCAVATOR / FRICTION WHEEL 1404ZW

## Working range grab

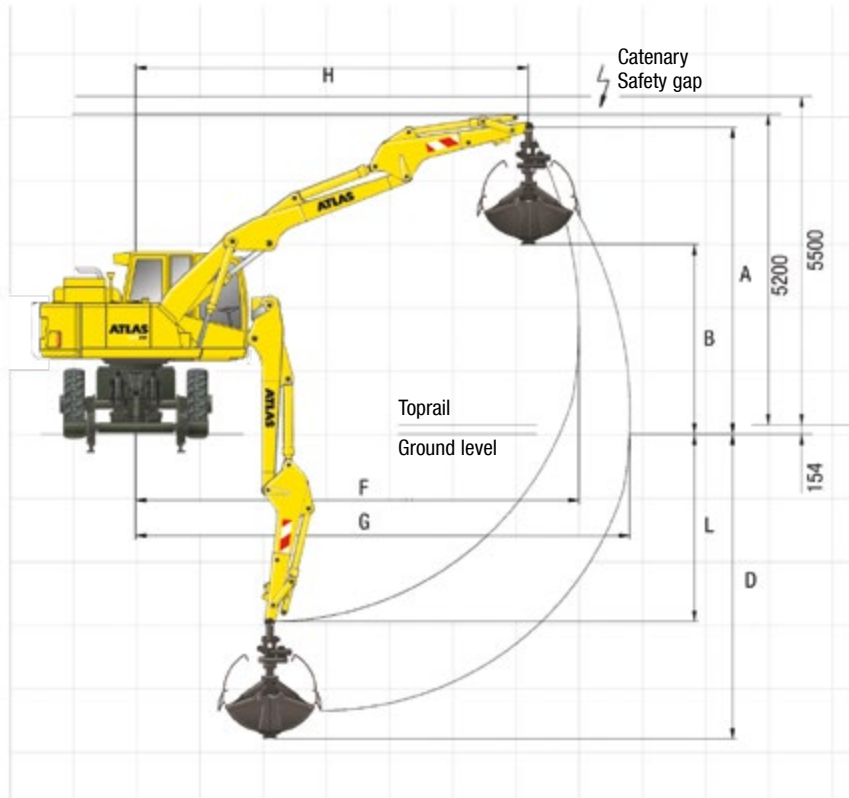

### Stick D41.22 - working length 2200 mm

Equipment: A41.4S, C53.41P, C53.46, D41.22, F31, E332, E344		Grab
A	Height of stick	mm 5140
B	Discharge height	mm 3180
D	Max. digging depth	mm 5100
F	Max. radius	mm 7400
G	Max. reach	mm 8250
H	Max. arm position	mm 6560
J	Max. reach height	mm -
L	Bucket pivot point	mm -
Grab		l 350
Grab clamping force		kN 73.0
Operating weight		t 18.0

## Working range bucket

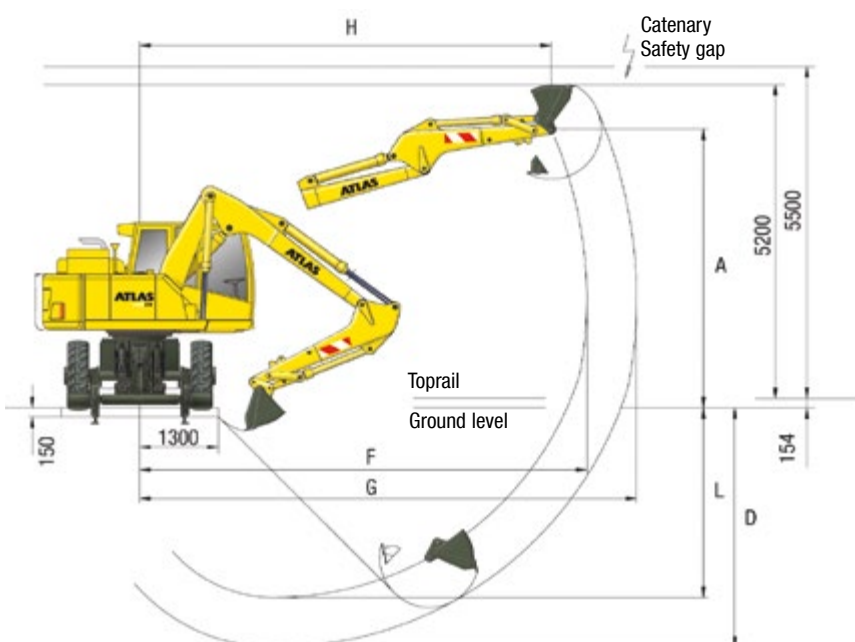

### Stick D41.22 - working length 2200 mm

Equipment: A41.5, C53.41P, C53.46, D41.22, F53.1, G649		Bucket
A	Height of stick	mm 4615
B	Discharge height	mm -
D	Max. digging depth	mm 3965
F	Max. radius	mm 7400
G	Max. reach	mm 8225
H	Max. arm position	mm 6815
J	Max. reach height	mm -
L	Bucket pivot point	mm 3140
Bucket		l 700
Stick digging force		kN 82
Bucket digging force		kN 130
Operating weight		t 17.8



# TECHNICAL SPECIFICATION SHEET RAIL-ROAD EXCAVATOR / FRICTION WHEEL 1404ZW

## Tailswing 1575 mm (4.5 t) 1000 mm track gauge

Hook height m	3.0 m		3.5 m		4.0 m		5.0 m		6.0 m		7.0 m		
	F	L	F	L	F	L	F	L	F	L	F	L	
5	a	–	–	–	–	5.3	4.7	5.4	3.4	4.2	2.5	–	–
	b	–	–	–	–	5.3	2.6	5.4	1.9	4.7	1.3	–	–
4	a	–	–	7.6	5.4	7.5	4.5	5.5	3.3	4.3	2.5	3.2	1.9
	b	–	–	7.6	2.8	7.5	2.4	6.0	1.8	4.7	1.3	3.6	0.9
3	a	8.7	6.7	8.4	5.3	7.6	4.4	5.5	3.3	4.2	2.5	3.2	1.9
	b	8.7	3.3	8.4	2.7	8.0	2.3	6.0	1.8	4.7	1.3	3.6	0.9
1	a	10.5	6.7	9.4	5.3	7.6	4.4	5.5	3.3	4.1	2.4	3.1	1.8
	b	10.5	3.3	9.6	2.7	8.2	2.3	6.0	1.7	4.6	1.2	3.6	0.8
0	a	11.6	6.4	9.5	5.1	7.7	4.3	5.4	3.1	4.0	2.3	3.1	1.8
	b	11.6	3.1	10.0	2.5	8.3	2.2	6.0	1.6	4.5	1.1	3.5	0.8
-1	a	12.1	6.2	9.7	5.0	7.7	4.1	5.3	3.0	3.9	2.3	–	–
	b	12.1	2.9	10.1	2.4	8.4	2.0	6.0	1.5	4.4	1.1	–	–
-2	a	12.4	6.1	9.6	4.9	7.6	4.1	5.2	2.9	–	–	–	–
	b	12.4	2.8	10.3	2.3	8.4	2.0	5.8	1.4	–	–	–	–

## Tailswing 1700 mm (5.3 t) 1000 mm track gauge

Hook height m	3.0 m		3.5 m		4.0 m		5.0 m		6.0 m		7.0 m		
	F	L	F	L	F	L	F	L	F	L	F	L	
5	a	–	–	–	–	5.3	5.2	5.4	3.8	4.6	2.8	–	–
	b	–	–	–	–	5.3	2.9	5.4	2.2	4.9	1.6	–	–
4	a	–	–	7.6	6.0	7.5	5.0	5.9	3.7	4.6	2.8	3.5	2.1
	b	–	–	7.6	3.2	7.5	2.7	6.0	2.1	5.0	1.6	3.9	1.1
3	a	8.7	7.4	8.4	5.9	8.0	4.9	5.9	3.7	4.6	2.8	3.5	2.1
	b	8.7	3.8	8.4	3.1	8.0	2.7	6.4	2.0	5.0	1.5	3.9	1.1
1	a	10.5	7.4	9.6	5.9	8.2	4.9	5.9	3.6	4.5	2.7	3.5	2.1
	b	10.5	3.8	9.6	3.1	8.5	2.7	6.3	2.0	5.0	1.5	3.9	1.1
0	a	11.6	7.1	10.0	5.7	8.2	4.8	6.0	3.5	4.4	2.6	3.4	2.0
	b	11.6	3.6	10.0	3.0	8.5	2.5	6.4	1.9	4.9	1.4	3.8	1.0
-1	a	12.1	6.9	10.1	5.6	8.3	4.6	5.9	3.4	4.3	2.6	–	–
	b	12.1	3.4	10.1	2.8	8.6	2.4	6.5	1.8	4.8	1.3	–	–
-2	a	12.4	6.9	10.3	5.5	8.3	4.6	5.7	3.3	–	–	–	–
	b	12.4	3.4	10.3	2.8	8.9	2.4	6.3	1.7	–	–	–	–

## Tailswing 1575 mm (4.5 t) 1435 mm track gauge

Hook height m	3.0 m		3.5 m		4.0 m		5.0 m		6.0 m		7.0 m		
	F	L	F	L	F	L	F	L	F	L	F	L	
5	a	–	–	–	–	5.3	4.7	5.4	3.4	4.2	2.5	–	–
	b	–	–	–	–	5.3	3.6	5.4	2.6	4.7	1.9	–	–
4	a	–	–	7.6	5.4	7.5	4.5	5.5	3.3	4.3	2.5	3.2	1.9
	b	–	–	7.6	4.0	7.5	3.4	6.0	2.5	4.7	1.9	3.6	1.4
3	a	8.7	6.7	8.4	5.3	7.6	4.4	5.5	3.3	4.2	2.5	3.2	1.9
	b	8.7	4.8	8.4	3.9	8.0	3.3	6.0	2.5	4.7	1.9	3.6	1.4
1	a	10.5	6.7	9.4	5.3	7.6	4.4	5.5	3.3	4.1	2.4	3.1	1.8
	b	10.5	4.8	9.6	3.9	8.2	3.3	6.0	2.4	4.6	1.8	3.6	1.3
0	a	11.6	6.4	9.5	5.1	7.7	4.3	5.4	3.1	4.0	2.3	3.1	1.8
	b	11.6	4.6	10.0	3.7	8.3	3.1	6.0	2.3	4.5	1.7	3.5	1.3
-1	a	12.1	6.2	9.7	5.0	7.7	4.1	5.3	3.0	3.9	2.3	–	–
	b	12.1	4.4	10.1	3.6	8.4	3.0	6.0	2.2	4.4	1.6	–	–
-2	a	12.4	6.1	9.6	4.9	7.6	4.1	5.2	2.9	–	–	–	–
	b	12.4	4.3	10.3	3.5	8.4	3.0	5.8	2.1	–	–	–	–

## Tailswing 1700 mm (5.3 t) 1435 mm track gauge

Hook height m	3.0 m		3.5 m		4.0 m		5.0 m		6.0 m		7.0 m		
	F	L	F	L	F	L	F	L	F	L	F	L	
5	a	–	–	–	–	5.3	5.2	5.4	3.8	4.6	2.8	–	–
	b	–	–	–	–	5.3	4.0	5.4	2.9	4.9	2.2	–	–
4	a	–	–	7.6	6.0	7.5	5.0	5.9	3.7	4.6	2.8	3.5	2.1
	b	–	–	7.6	4.5	7.5	3.8	6.0	2.8	5.0	2.2	3.9	1.6
3	a	8.7	7.4	8.4	5.9	8.0	4.9	5.9	3.7	4.6	2.8	3.5	2.1
	b	8.7	5.4	8.4	4.4	8.0	3.7	6.4	2.8	5.0	2.1	3.9	1.6
1	a	10.5	7.4	9.6	5.9	8.2	4.9	5.9	3.6	4.5	2.7	3.5	2.1
	b	10.5	5.4	9.6	4.4	8.5	3.8	6.3	2.8	5.0	2.1	3.9	1.5
0	a	11.6	7.1	10.0	5.7	8.2	4.8	6.0	3.5	4.4	2.6	3.4	2.0
	b	11.6	5.2	10.0	4.2	8.5	3.6	6.4	2.7	4.9	2.0	3.8	1.5
-1	a	12.1	6.9	10.1	5.6	8.3	4.6	5.9	3.4	4.3	2.6	–	–
	b	12.1	5.0	10.1	4.1	8.6	3.4	6.5	2.6	4.8	1.9	–	–
-2	a	12.4	6.9	10.3	5.5	8.3	4.6	5.7	3.3	–	–	–	–
	b	12.4	5.0	10.3	4.0	8.9	3.4	2.5	2.5	–	–	–	–

a = travel on road permitted, b = travel on rail permitted, L = Lateral, F = Front

All values in tonnes (t) were determined acc. to ISO 10567 and include a stability factor of 1.33 or 87% of the hydraulic lifting capacity. These values are applicable at the top of the arm with optimum positioning of the corresponding boom system.

## Operating weights, tailswing

Type	Configuration	Operating weight with boom adjusting mechanism	Tailswing mm
1404 ZW	A41.4S	17 t	1575
1404 ZW	A41.4S	17.6 t	1700 (4.9 t)
1404 ZW	A41.4S	18 t	1700 (5.3 t)

### Approvals

The equipment marked \* is an essential requirement of the German Federal Railways for operation on their network.

The safety testing is conducted by the health and safety executive (Berufsgenossenschaft), compliance with the appropriate regulations is verified by the German Federal Railways and the TÜV.

## Additional and special equipment

- Short tailswing version (1575, 1700 (4.9 t), 1700 (5.3 t) tailswing (mm))\*
- Two-man cab\*
- Auxiliary heating
- Hose-rupture safety device for lifting operation, overload warning device\*
- Trailer hitch on chassis\*
- Emergency manual hydraulic pump\*
- Special tow bar\*
- German Federal Railways approved lights\*
- Lift limitation electronically adjustable from the cab\*
- Swing limitation adjustable from the cab\*
- Wagon brake unit with footplate brake valve, permitted trailer load is 120 t
- Factory Federal German Railways approval with appropriate certification and all necessary accessories: fire extinguisher, first aid kit, earth cable, red/white flag, torch with red dimmable light, loud hailer, digital speed measurement instrument, oil spill tarpaulin and oil binder\*
- Rotating beacons
- Working floodlight(s)
- Radio
- Refueling pump
- Rail bogie for track gauge 1000 / 1435 mm
- TÜV-approval
- Track gauge 1435 mm\*

Items marked with \* are a requirement for Federal German Railway approval

# TECHNICAL SPECIFICATION SHEET

## RAIL-ROAD EXCAVATOR 1604ZW

### Main dimensions

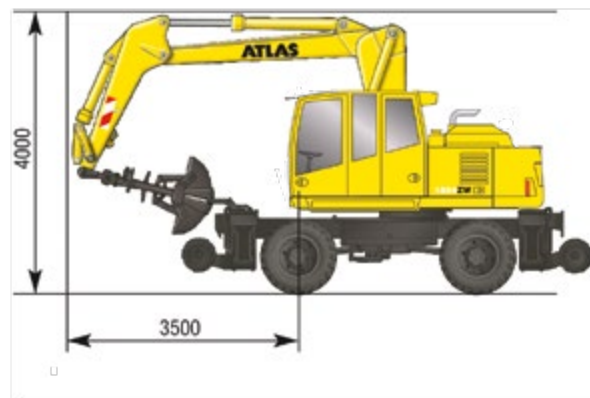
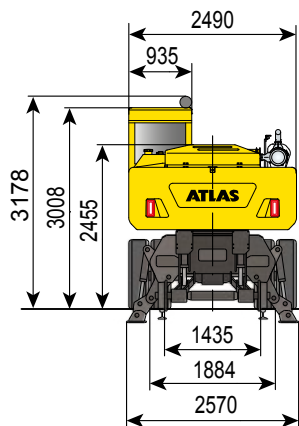
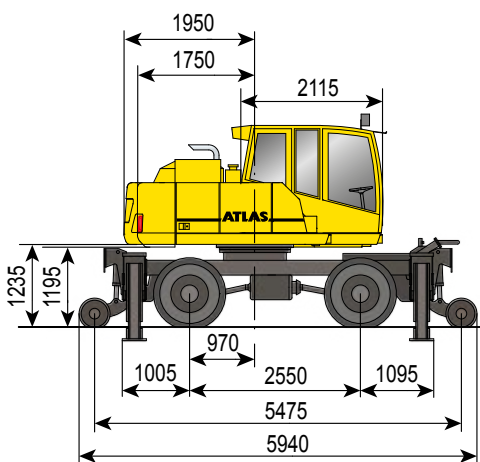

### Working equipment:

#### Base machine

A67.5 Rail-Road hydraulic excavator 1604 ZW, with 4 outriggers, tailswing 1750 mm

Weight/kg

18100

#### Additional and special equipment

B66.41 Hose-rupture safety device for lifting cylinder, overload warning device

10

B67.20 Counterweight, tailswing 1950 mm

0

B66.39 Additional hydraulic unit for variable boom cylinder

B41.23 Two man fully glazed cab

300

#### Base section of arm and boom

C67.41P Base arm with two lift cylinders and an internally mounted operating cylinder

1350

C66.46 Boom with articulating cylinder only for base arm C67.41P, working length 3300 mm

930

#### Sticks

D67.22 Rail-road excavator stick, working length 2240 mm

600

#### Bucket tipping cylinder

F66.1 Bucket tipping cylinder with reversing linkage

180

#### Standard equipment

- Narrow axles for underground and suburban railways
- Central lubrication
- Maintenance point for filtration system
- Proportional Grab-rotation
- Hydraulic system for grab and grab rotation function
- Tank indicator
- Battery main switch in negative lead
- "Travel" function via foot control
- Accumulator for emergency lowering of boom system
- Traction increase
- Sliding window in cab door
- Power shift transmission
- Windshield washer system
- Tilt and height adjustable steering column
- Radio pre-installation
- Storage box in the cab
- Comfort seat with armrests and lumbar support
- Toolbox on chassis
- Sealed pivot points in the base section of the boom
- Boom and stick with 50 hour maintenance intervals
- Securing lug for securing the grab during road travel
- Air-conditioning
- Air dryer for compressed air system



# TECHNICAL SPECIFICATION SHEET

## RAIL-ROAD EXCAVATOR 1604ZW

### Engine

Power rating acc. to ISO 1585	115 kW (157 HP)
Manufacturer	Deutz
Type	TCD 4.1 (Stage Tier 3B)
Displacement	4000 cm <sup>3</sup>
Rotational speed	1800 rpm
Design	Turbocharger/charge-air cooling

### Hydraulic system

Computer controlled AWE4 system with a load limiting high performance piston-pump and fuel efficient on-demand power control for sensitive, proportional and load independent ramp-up of all operational movements

- Primary and secondary protection of the hydraulic system against overload
- Suction valve for all operational functions as well as restrictors in the lift and articulating circuits
- Pipe break protection valves for lifting and articulated cylinders

Hydraulic system	1 x AKP
Main pump	HPR 210
Max. flow variable capacity pump	380 l/min
Max. operating pressure for operating movements	340 bar

### Noise level

Noise level\* is significantly below EC limits

Ambience level (L <sub>WA</sub> )	97 dB (A)
Cab level (L <sub>WA</sub> )	71 dB (A)

\*Dynamic sound level measurement according to 2000/14 EC

### Electrical system

Operating voltage	24 Volt
Cold-start heavy duty battery	2 x 100 Ah
Electrical system in compliance with STVZO (Regulations Authorizing the Use of Vehicles for Road Traffic in Germany) and European standard	

### Brakes

Service brake	pneumatic-hydraulically actuated drum brake
Parking brake	pneumatically-operated spring-loaded parking brake

Emergency brake for use on rail	
Max. un-braked trailer load	40 t
Max. trailer load with wagon brake	120 t

### Fluid capacities

Fuel tank	260 l
Hydraulic tank	300 l
Engine oil	10 l

### Cab

Flexibly mounted • Heat absorbing extra wide windscreen for all-round vision  
 • Glare-free interior • Ergonomic pilot control levers • Adjustable steering column  
 • Lengthways adjustment of the seat independent of the control console • Front windscreen stowable under the cab roof • Second seat for mate

Type	935 two-man comfort cab	
Overall length	2130 mm	
Width	935 mm	

### Swing mechanism

Swing motor	axial piston motor with priority valve
Swing gear	planetary reduction
Swing brake	multi-disc brake

Drive via an internally toothed swing bearing	
Swing speed	9 rpm
Swing torque	59 kNm

### Power Transmission

40 t special excavator axles with planetary drives to all four wheel hubs

- All-wheel drive • Variable drive engine • Double acting travel brake valve
- Travel direction selector with steering column mounted lever or switch on pilot control lever • Steering axle with automatic oscillation lock • Travel controls via foot pedal valve • Power shift transmission • Traction increase

### Travel speed

Road and rail operation	
Crawling speed	max. 1.3 km/hour
Off-road speed	max. 5.6 km/hour
Highway speed	max. 20 km/hour
Rail guidance, track gauge 1435 mm, other widths on request	

### Tires

8 x	10.00 - 20
(inner tyre - highway, outer tyre - off highway tread pattern)	

### Weight

Operating weight	21.0 - 23.0 t
------------------	---------------



# TECHNICAL SPECIFICATION SHEET

## RAIL-ROAD EXCAVATOR 1604ZW

### Working range grab

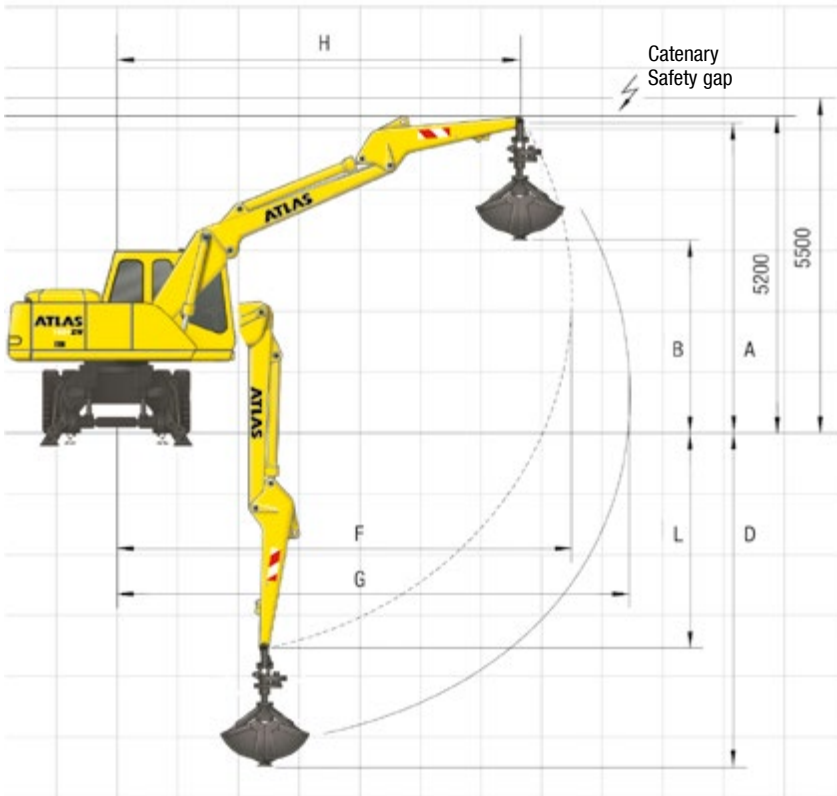

#### Stick D67.22 - working length 2240 mm

Equipment: A67.5, C67.41P, C66.46, D67.22, T31, E332, E346

			Grab
S	Height of stick	mm	5100
B	Discharge height	mm	3150
D	Max. Digging depth	mm	5500
F	Max. Reach	mm	7450
G	Max. Reach	mm	8300
H	Max. arm position	mm	6600
J	Max. reach height	mm	–
L	Bucket pivot point	mm	3550
	Grab	l	450
	Grab clamping force	kN	72.8
	Operating weight	t	21.3

### Working range bucket

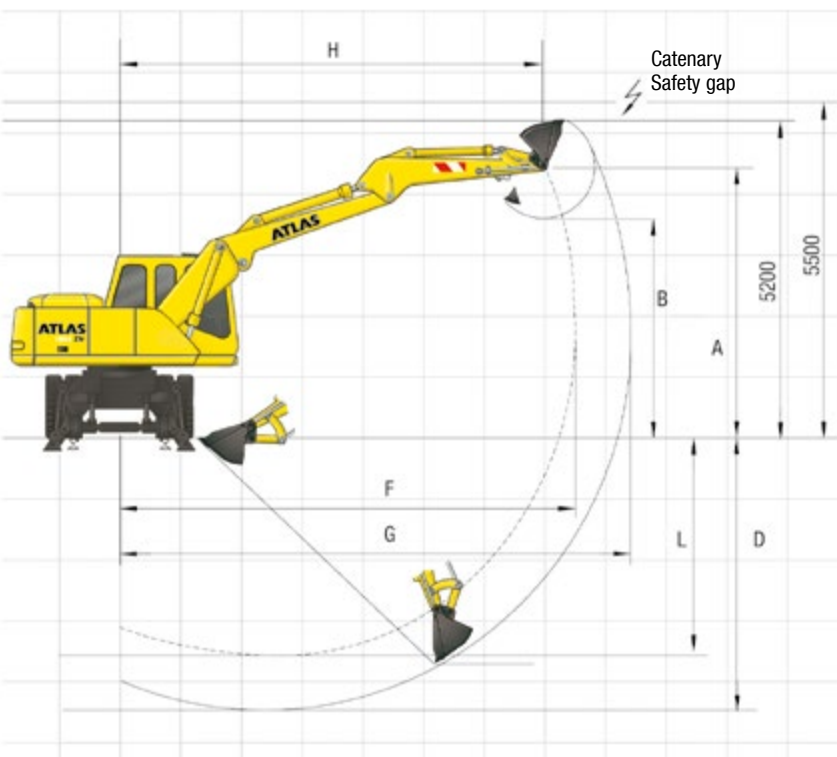

#### Stick D67.22 - working length 2240 mm

Equipment: A67.5, C67.41P, C66.46, D67.22, G649

			Bucket
S	Height of stick	mm	4400
B	Discharge height	mm	3650
D	Max. Digging depth	mm	4450
F	Max. Reach	mm	7450
G	Max. Reach	mm	8350
H	Max. arm position	mm	6950
J	Max. reach height	mm	–
L	Bucket pivot point	mm	3550
	Buckets	l	800
	Stick digging force	kN	112
	Bucket digging force	kN	141
	Operating weight	t	21.0



# TECHNICAL SPECIFICATION SHEET

## RAIL-ROAD EXCAVATOR 1604ZW

Base machine A67.5, C67.41P, C66.46

### Stick D67.22 - working length 2240 mm Tailswing 1750 mm

Hook height m		3.0 m		4.0 m		4.5 m		5.0 m		6.0 m		7.0 m	
		F	L	F	L	F	L	F	L	F	L	F	L
5	a	-	-	-	-	6.9	5.7	6.5	4.9	6.0	3.7	-	-
	b	-	-	-	-	6.9	3.6	6.5	3.1	6.0	2.3	-	-
4	a	-	-	7.7	6.7	7.2	5.7	6.7	4.9	6.0	3.7	-	-
	b	-	-	7.7	4.1	7.2	3.5	6.7	3.1	6.0	2.3	-	-
3	a	11.0	10.1	9.4	6.5	8.3	5.5	7.5	4.8	6.4	3.7	5.7	2.8
	b	11.0	5.8	9.4	4.0	8.3	3.4	7.5	3.0	6.4	2.3	5.7	1.7
1	a	12.7	9.9	10.6	6.4	9.2	5.5	8.2	4.8	6.8	3.6	5.8	2.7
	b	12.7	5.7	10.6	3.9	9.2	3.4	8.2	3.0	6.8	2.2	5.8	1.6
0	a	14.6	9.7	10.7	6.3	9.4	5.3	8.4	4.6	6.9	3.4	5.7	2.7
	b	14.6	5.5	10.7	3.8	9.4	3.2	8.4	2.8	6.9	2.1	5.7	1.6
-1	a	15.1	9.3	10.9	6.1	9.5	5.1	8.6	4.4	6.7	3.3	-	-
	b	15.1	5.2	10.9	3.5	9.5	3.0	8.6	2.6	6.7	1.9	-	-
-2	a	15.0	9.4	10.1	5.9	8.3	5.0	-	-	-	-	-	-
	b	15.0	5.2	10.1	3.4	8.3	2.9	-	-	-	-	-	-

a = travel on road permitted, b = travel on rail permitted, q = lateral, l = longitudinal

All values in tonnes (t) were determined acc. to ISO 10567 and include a stability factor of 1.33 or 87% of the hydraulic lifting capacity. These values are applicable at the top of the arm with optimum positioning of the corresponding boom system.

### Rail guidance

Track gauge 1435 mm, other widths on request.

#### CARSY (Computer assisted rail contact pressure system)

Automatic system for regulating and monitoring the force of the rail guide wheels. The required pressures are automatically set, continuously monitored and adjusted if necessary. Depending on the pre-selected operating condition, each separate guidance bogie wheel is set to a different pressure in accordance with a prescribed schedule, locked or hydraulically trailed.

The front and rear bogie wheels can be independently switched to permit simple de-railing and positive crossing of rail points.

Automatic self-diagnosis of the electronic system. Emergency function: de-railing is assured even in the event of a fault or complete breakdown.

### Operating weights, tailswing

Type	Configuration	Operating weight with boom adjusting mechanism	Tailswing mm	Can be operated on the network of the German Federal Railways.
1604 ZW, with 4 outriggers	A67.5	approx. 22.0 t	1750	Track spacing $\geq 3700$ mm
1604 ZW, with 4 outriggers	A67.5	approx. 22.2 t	1950	Track spacing $\geq 4,000$ mm

#### Approvals

The equipment marked \* is an essential requirement of the German Federal Railways for operation on their network. The safety testing is conducted by the health and safety executive (Berufsgenossenschaft), compliance with the appropriate regulations is verified by the German Federal Railways and the TÜV.

### Stick D67.22 - working length 2240 mm Tailswing 1950 mm

Hook height m		3.0 m		4.0 m		4.5 m		5.0 m		6.0 m		7.0 m	
		F	L	F	L	F	L	F	L	F	L	F	L
5	a	-	-	-	-	6.9	6.0	6.5	5.1	6.0	3.9	-	-
	b	-	-	-	-	6.9	3.8	6.5	3.3	6.0	2.5	-	-
4	a	-	-	7.7	7.1	7.2	6.0	6.7	5.1	6.0	3.9	-	-
	b	-	-	7.7	4.4	7.2	3.8	6.7	3.3	6.0	2.5	-	-
3	a	11.0	10.5	9.4	6.9	8.3	5.8	7.5	5.0	6.4	3.9	5.7	2.9
	b	11.0	6.2	9.4	4.2	8.3	3.6	7.5	3.2	6.4	2.5	5.7	1.8
1	a	12.7	10.4	10.6	6.8	9.2	5.8	8.2	5.0	6.8	3.8	5.8	2.9
	b	12.7	6.1	10.6	4.2	9.2	3.6	8.2	3.2	6.8	2.4	5.8	1.8
0	a	14.6	10.2	10.7	6.6	9.4	5.6	8.4	4.8	6.9	3.6	5.7	2.8
	b	14.6	5.9	10.7	4.0	9.4	3.5	8.4	3.0	6.9	2.2	5.7	1.7
-1	a	15.1	9.9	10.9	6.4	9.5	5.4	8.6	4.6	6.7	3.5	-	-
	b	15.1	5.6	10.9	3.8	9.5	3.3	8.6	2.8	6.7	2.1	-	-
-2	a	15.0	9.9	10.1	6.3	8.3	5.2	-	-	-	-	-	-
	b	15.0	5.6	10.1	3.7	8.3	3.1	-	-	-	-	-	-

### Additional and special equipment

- Short tailswing version (1750 or 1950 mm tailswing)\*
- Two-man cab\*
- Auxiliary heating
- Hose-rupture safety device for lifting operation, overload warning device\*
- Trailer hitch on chassis\*
- Emergency manual hydraulic pump\*
- Special tow bar\*
- German Federal Railways approved lights\*
- Lift limitation electronically adjustable from the cab\*
- Swing limitation adjustable from the cab\*
- Wagon brake unit with footplate brake valve, permitted trailer load is 120 t
- Factory Federal German Railways approval with appropriate certification and all necessary accessories: fire extinguisher, first aid kit, earth cable, red/white flag, torch with red dimmable light, loud hailer, digital speed measurement instrument, oil spill tarpaulin and oil binder\*
- Rotating beacons
- Working floodlight(s)
- Radio
- Refueling pump
- Rail bogie with track gauges of up to approx. 1700 mm
- TÜV-approval

Items marked with \* are a requirement for Federal German Railway approval

# ATLAS

## RAIL-ROAD EXCAVATORS

### **GANDERKESEE FACTORY**

Atlas Maschinen GmbH  
Atlasstrasse 6  
27777 Ganderkesee,  
Deutschland

Tel.: +49 (0) 4222 954 0  
Fax: +49 (0) 4222 954 220  
E-mail: [info@atlasgmbh.com](mailto:info@atlasgmbh.com)  
[www.atlasgmbh.com](http://www.atlasgmbh.com)



### **VECHTA FACTORY**

Atlas Maschinen GmbH  
Theodor-Heuss-Str. 3  
49377 Vechta  
Deutschland

Tel.: +49 (0) 4441 954-0  
E-mail: [info@atlasgmbh.com](mailto:info@atlasgmbh.com)  
[www.atlasgmbh.com](http://www.atlasgmbh.com)



### **DELMENHORST FACTORY**

Atlas Maschinen GmbH  
Stedinger Strasse 324  
27751 Delmenhorst  
Deutschland

Tel.: +49 (0) 4221-491-0  
Fax: +49 (0) 4221-491-443  
E-mail: [info@atlasgmbh.com](mailto:info@atlasgmbh.com)  
[www.atlasgmbh.com](http://www.atlasgmbh.com)

### **ATLAS CRANES UK LTD NATIONAL SALES & SERVICE FACILITY**

Wharfedale Road,  
Euroway Trading Estate  
Bradford, West Yorkshire BD4 6SL

Tel.: 08444 99 66 88 Option 3  
E-mail: [atlasuk@atlasgmbh.com](mailto:atlasuk@atlasgmbh.com)  
[www.atlas-cranes.co.uk](http://www.atlas-cranes.co.uk)  
[www.atlasgmbh.com](http://www.atlasgmbh.com)

