

## New Holland Construction range for agriculture



## Proven solutions designed around your needs.

New Holland has now broadened its product offering to cater for the more specialised applications found within the wide scope of modern agriculture.

Building on a long tradition of listening to and understanding our customer's needs, New Holland brings to you a selection of its construction equipment range, chosen for their ability to perform specialized operations in agricultural environments. Whether the application is bulk material handling on large scale commercial farms and contracting businesses, drainage or row maintenance on speciality fruit farms, or the diverse range of daily tasks performed on livestock units, having the right tool is the key to efficiency, productivity and profitability. Available through the New Holland Agriculture dealer network, this range of Skid Steer Loaders & Compact Track Loaders, Mini Crawler Excavators, Backhoe Loaders and Wheel Loaders will deliver proven, rock solid performance all year round.

**New Holland. Your farming partner.**





## Contents

<b>2 / 3</b>	Introduction
<b>4 / 5</b>	Applications
<b>6 / 7</b>	Skid Steer Loaders & Compact Track Loaders
<b>8 / 9</b>	Mini Crawler Excavators
<b>10 / 11</b>	Backhoe Loaders
<b>12 / 13</b>	Wheel Loaders
<b>14 / 17</b>	Specifications
<b>18 / 19</b>	Attachments - Support and Services

# The right tool for the job.

The New Holland Construction range can utilize a variety of specialist, purpose-made attachments to use in a wide range of agricultural applications. New Holland dealers can also offer further accessories to match more specific demands and have the knowledge and expertise to help ensure you make the right choices. What always stays the same is New Holland's commitment to operator comfort and safety, strict adherence to best environmental practice, optimized performance and reduced whole life operating costs.



## ORCHARDS, VINEYARDS AND SPECIALIZED FARMING



Key applications	Skid Steer Loaders & Compact Track Loaders	Mini Crawler Excavators
Row maintenance		●
Mowing	●	●
Tree shaking	●	
Post hole boring	●	●
Small scale forestry establishment	●	●
Box filling	●	
Market gardening	●	●
Loading	●	●
Materials handling	●	
Land drainage / drain cleaning		●
Yard & road sweeping	●	
Shallow trenching	●	●
<b>Winter duties:</b> snowplough, snow blower, gritter	●	



## CASH CROP FARMING



Key applications	Skid Steer Loaders & Compact Track Loaders	Backhoe Loaders	Wheel Loaders
Grain handling			●
Bale handling	●		●
Bulk truck loading		●	●
Land drainage / drain cleaning		●	
Yard & road sweeping	●		
Box filling	●		
General materials handling	●	●	●
<b>Winter duties:</b> snowplough, snow blower, gritter	●		●

# Manage your machine from the comfort of your office.

PLM® Connect enables you to connect to your machines from the comfort of your office through the utilization of the mobile network. You can stay in touch with your machines at all times, and even send and receive real-time information that saves time and enhances productivity. PLM® Connect is available for the range of 200 Series Skid Steer Loaders & Compact Track Loaders, Backhoe Loaders and Wheel Loaders.



## LIVESTOCK AND MIXED FARMING



Key applications	Skid Steer Loaders & Compact Track Loaders	Mini Crawler Excavators	Backhoe Loaders	Wheel Loaders
Grain handling				•
Bale handling	•			•
Yard & road sweeping	•			
Land drainage / drain cleaning		•	•	
General material handling	•		•	•
Track maintenance	•	•	•	
Winter feeding	•			•
Forage ensiling				•
Manure handling	•		•	•
Post hole boring	•	•	•	
Yard scraping	•			
Fence construction / maintenance	•	•	•	
<b>Winter duties:</b> snowplough, snow blower, gritter	•			•



## ENERGY GROWING & BIOMASS BUSINESS



Key applications	Skid Steer Loaders & Compact Track Loaders	Backhoe Loaders	Wheel Loaders
Grain & biomass loading			•
Bale handling	•		•
Biomass ensiling			•
Land drainage / drain cleaning		•	
Yard & road sweeping	•		
Digester filling			•
Bulk materials re-handling			•
<b>Winter duties:</b> snowplough, snow blower, gritter	•	•	•

# The 200 Series range of Skid Steer Loaders & Compact Track Loaders. Powerfully compact.

The New Holland 200 Series range of skid steer loaders & compact track loaders deliver superior performance in a compact package. The range consists of seven skid steer loader models, with operating weights from 2300kg up to 4200kg, and four compact track loaders with operating weights of 3700kg and 4600kg, and lift heights from 2.85m to 3.3m. You will race through your tasks in the tightest spaces thanks to their compact size, exceptional all round visibility and maneuverability, and without compromising comfort or safety. The compact dimensions of under 2m height and just over 1.5m width on the smallest model, ensure access through the narrowest gates and passageways. On Super Boom models the superior lift height and forward reach allows for efficient and easy filling and loading, allowing the load to be dropped into the center of the trailer or feed wagon. Your productivity will soar with the fast cycle times resulting from the perfect balance, excellent stability and powerful hydraulic system. Offering class leading space, comfort and ergonomics, the Comfort Deluxe Cab also affords excellent all round visibility and reduced blind spots.



- Mowing
- Tree shaking, Post hole boring
- Small scale forestry establishment
- Box filling, loading and materials handling
- Market gardening, Yard & road sweeping
- Shallow trenching
- Winter duties: snowplough, snow blower, gritter



- Yard & road sweeping
- Box filling, Bale handling
- General materials handling
- Winter duties: snowplough, snow blower, gritter



- Bale handling, Yard & road sweeping
- General materials handling, Track maintenance
- Winter feeding, Manure handling
- Post hole boring, fence construction / maintenance
- Yard scraping, Winter duties: snowplough, snow blower, gritter



- Bale handling
- Yard & road sweeping
- Winter duties: snowplough, snow blower, gritter



In 2017 New Holland produced its 250,000<sup>th</sup> skid steer loader. The manufacture of New Holland skid steer loaders began 45 years ago in North America, and to this day we pride ourselves as being the pioneers of the Super Boom design concept, offering best in class forward reach and lift height combined with unparalleled operator safety.





### Best-in-class lift height and reach

The vertical lift geometry of the Super Boom system enables operators to load material far beyond the reach and height of most other skid steer loader designs. The exceptional forward reach afforded by this design makes loading bales and reaching over feed barriers an effortless task.



### Unparalleled pushing power

L213, L216, L221 and C227 models, offered exclusively with the radial-lift boom, are ideal for digging and pushing. Productivity in applications such as manure handling, soil moving and yard scraping is boosted by their outstanding breakout force and the geometry of the arm.



### Comfort Deluxe Cab

The Comfort Deluxe Cab design offers best-in-class comfort, with plenty of head and leg room, in addition, the low noise levels will be appreciated by people or livestock within the working range of the machine. A choice of control layouts are available, either mechanical or electro hydraulic joystick control can be specified.



### Tier 4 technology boosts productivity

New Holland Tier 4 machines deliver power and performance in an environmentally friendly way. New technological solutions, such as electronic engine control, Cooled Exhaust Gas Recirculation (CEGR) or Diesel Oxidation Catalyst (DOC) after-treatment systems, deliver more power, more precision and optimize fuel usage.



### Easy maintenance

Maintenance and servicing on 200 Series skid steer loaders and compact track loaders couldn't be easier, access for engine and hydraulic oil changes is via a removable cover on the left rear quarter. The ground level daily service points are grouped together at the rear for convenience.

Models		L213	L216	L218	L220	L221	L228	L234	C227	C232	C234	C238
Max. power	[kW/hp[CV]]	36.4/49	44.7/61	44.7/61	50/68	55/75	55/75	67/91	55/75	55/75	67/91	67/91
Max. lift height (bucket hinge pin)	(mm)	2845	2845	3048	3073	3124	3287	3327	3124	3330	3215	3227
Chassis design		wheels	wheels	wheels	wheels	wheels	wheels	wheels	tracks	tracks	tracks	tracks
Boom design		Radial Lift	Radial Lift	Super Boom	Super Boom	Radial Lift	Super Boom	Super Boom	Radial Lift	Super Boom	Radial Lift	Super Boom
Rated Operating Capacity (ROC)*	(kg)	590	725	818	905	905	1270	1545	1225	1450	1540	1723
Rated Operating Capacity (ROC) with counterweights*	(kg)	635	770	863	950	950	1400	1680	-	-	-	-
Tipping load	(kg)	1179	1455	1633	1814	1814	2540	3090	2449	2900	3080	3447
Width	(mm)	1518	1518	1678	1755	1755	1768	1930	1676	1930	1930	1930
Height	(mm)	1919	1919	1974	1998	1998	2002	2042	1998	2043	2043	2043
Operating weight	(kg)	2300	2505	2832	2930	3160	3740	4136	3720	4370	4536	4581

- Not available \* 50% of tipping load

# Mini Crawler Excavators. Breaking new ground.

With New Holland's new C Series mini excavators ranging from 1.7 to 6.0 tons, you know you will be able to deliver big performance in the tightest spaces thanks to their short radius design and fast, smooth simultaneous movements. Whether you are digging drains, preparing sites for poly-tunnels, establishing tree plantations or improving the farms tracks, you will appreciate the power and versatility of the new eight model line up. And what's more, you know you can count on their exceptional reliability, so you will hardly know what down time is.



- Land drainage / drain cleaning
- Row maintenance
- Post hole boring
- Small scale forestry establishment
- Market gardening, loading
- Mowing
- Shallow trenching



- Land drainage / drain cleaning
- Track maintenance
- Post hole boring
- Fence construction / maintenance







### Unique features for productive performance

The top two C Series models feature hydraulic flow summation. This advanced system delivers the enhanced proportional control typical restricted to high capacity excavators exceeding 20t capacity. A choice of four different track types are also available.



### Short radius design

The Short Radius SR concept means that the machines counterweight always stays within the track width. This feature allows the ability to work in confined environments and reduced damage risk to the machine, and everything around it.



### Comfortable surroundings

The cabs on the new C Series SR mini excavators are among the largest in their class and feature a comfortable suspended seat, sliding side window, LCD touchscreen interface and air conditioning on the larger models. A host of convenient features more commonly associated with the automotive sector are offered across the range.



### Clean and efficient power units

Our clean and efficient engines comply with all European regulations and provide superior digging performance with low fuel consumption and noise levels.

Models		E17C	E18C	E26C	E30C	E33C	E37C	E57C	E60C
Power	[kW/hp(CV)]	12.5/16.8	12.5/16.8	18.5/24.8	18.5 / 24.8	18.2/24.4	18.2/24.4	49.8/66.9	48.3/64.7
<b>Operating Weight</b>									
Cab	(kg)	-	1890	2650	3000	-	3760	5580	5980
Canopy	(kg)	1770	1720	2500	2890	3150	3620	-	-
Blade width	(mm)	990 - 1300	980 - 1250	1500	1550	1550	1740	1920	1980
Variable width undercarriage		●	●	-	-	-	-	-	-
Max. digging depth (Short arm / Long arm)	(mm)	2200 / 2350	2250 / 2400	2420 / 2645	2500/2720	3035 / 3335	3135 / 3440	3820 / 4060	3570 / 3990
Max. dump height (Short arm / Long arm)	(mm)	2570 / 2670	2550 / 2660	2930 / 3030	2890/3030	3275 / 3455	3425 / 3615	4050 / 4180	3930 / 4100
Max. rated hydraulic flow	(l/min)	2 x 18.8	2 x 17.0	2 x 27.6	2 x 27.6	2 x 37.4	2 x 37.4	2 x 57.8	2 x 55
Travel speed (High)	(kph)	4.3	4.1	4.5	4.3	4.2	4.4	4.1	3.9

● Standard – Not available

# Backhoe Loaders. Versatility in all fields.

Versatile and productive, New Holland's updated C Series backhoe loader is an excavator and a wheel loader rolled into one. The boom is designed like the arm of an excavator with the performance to match. Offering the ability to do a multitude of different tasks, no other machine on the farm says "multi-purpose" like the C Series. Boasting three models in the range, from 98hp(CV) to 111hp(CV), with the range topping equal wheel, four-wheel-steer configuration featured on the B115C. Particularly useful on busy livestock units, the C Series' extremely powerful front loader can lift over 3.5 tons, and has a useful lift height of 3.5m. Materials handling and drainage can be performed fast, easily and without fuss or adaptation. This versatility and performance comes with big savings in the cost of ownership with exceptionally low fuel consumption and easy serviceability.



- Bulk truck loading
- Land drainage / drain cleaning
- General materials handling
- Winter duties: snowplough



- Land drainage / drain cleaning
- General materials handling
- Track maintenance
- Post hole boring
- Fence construction / maintenance
- Winter duties: snowplough
- Manure handling



- Land drainage / drain cleaning
- Winter duties: snowplough





### Hydraulic versatility

To exactly match end user needs, New Holland backhoe loaders are offered with a choice of twin gear pump or a variable displacement pump. In addition, an auxiliary hydraulic circuit is available to power attachments to include hydraulic breakers and soil augers.



### Choice of transmissions

Just as you would expect from New Holland, there is a choice of transmission options available, choose between the standard Powershuttle option or the more advanced Powershift option featuring full auto mode and kick-down function.



### Clean performance

Developing 98 or 111hp dependent upon model, the FPT Industrial 3.4 litre four-cylinder engine in backhoe loaders is the same unit proven in New Holland T5 tractors, and is compliant with stringent Tier 4B emission regulations thanks to advanced Compact HI-eSCR technology.



### Class-leading operator environment

Climb aboard the cab of the C Series backhoe loaders and you find a comfortable, well-appointed operator environment with low noise levels of just 77dB(A). All the controls for the front loader are positioned on a single, right hand joystick. The fully adjustable deluxe air seat and can be turned through 180 degrees to reposition for use with the backhoe. Two floor mounted electro hydraulic joysticks provide control to the backhoe, while further controls for the jacks and side shift are located on the joystick columns.

Models	B100C TC		B110C TC		B115C TC	
	retracted	extended	retracted	extended	retracted	extended
Rated engine power ISO TR14396 - ECE R120	[kW/hp(CV)] 73/98		83/111		83/111	
Loader lift capacity to max. height	(kg) 3450		3553		3075	
Loader max. lift height (hinge pin)	(mm) 3458		3458		3478	
Backhoe max. digging depth	(mm) 4600	5785	(mm) 4600	5785	4489	5673
Backhoe max. digging reach (ground level)	(mm) 5448	6542	(mm) 5448	6542	5433	6529
Stabilizer width	(mm) 2275		2275		2275	
Height (to top of cab)	(mm) 2940		2940		3000	
Operating weight with standard backhoe and 4-in-1 bucket	(kg) 8120		8120		8370	
Operating weight with extendible backhoe and 4-in-1 bucket	(kg) 8800		8800		9100	

# Wheel Loaders.

## Driving pleasure, loading excellence.

The bulk handling and loading of grain, farm yard manure and biomass digestate requires a dedicated heavy duty machine to cope with the heavy payloads and repetitive duty cycles. Equally important is the ability to push and climb when ensiling grass or maize forage. The new D Series New Holland wheel loaders are perfectly suited to these tasks and the range now features the new flagship heavyweight W190D model, with 234hp(CV) FPT Industrial NEF engine and available in Z-Bar and Long Reach configurations. The new best in class cab features outstanding visibility, combined with joystick control with programmable return functions ensures the operator is as productive as possible during the busy silage or harvest seasons.



- Grain handling
- Bale handling
- Bulk truck loading
- General materials handling
- Winter duties: snowplough, snow blower



- Grain handling
- Bale handling
- General materials handling
- Winter feeding
- Forage ensiling
- Manure handling
- Winter duties: snowplough, snow blower



- Grain & biomass loading
- Bale handling
- Biomass ensiling
- Digester filling
- Bulk materials re-handling
- Winter duties: snowplough, snow blower





## 200 Series Skid Steer Loaders & Compact Track Loaders

### L213 - L216 - L218 - L220 - L221 - L228 - L234 - C227 - C232 - C234 - C238



Models	L213	L216	L218	L220	L221	L228	L234	C227	C232	C234	C238
<b>Engine</b>	ISM/N844L-F IDI	ISM/N844LT-F IDI	ISM/N844LTA-DI-F	ISM/N844LTA-DI-F	FPT F5H	FPT F5H	FPT F5H	FPT F5H	FPT F5H	FPT F5H	FPT F5H
Max. power [kW/hp(CV)]	36.4/49	44.7/61	44.7/61	50/68	55/75	55/75	67/91	55/75	55/75	67/91	67/91
Capacity (L)	2.2	2.2	2.2	2.2	3.4	3.4	3.4	3.4	3.4	3.4	3.4
No of cylinders / Aspiration / Emission level Tier-Stage	4 / N / 4A-3B	4 / T / 4B-4	4 / T / 4B-4	4 / T / 4B-4	4 / T / 4B-4	4 / T / 4B-4	4 / T / 4B-4	4 / T / 4B-4	4 / T / 4B-4	4 / T / 4B-4	4 / T / 4B-4
Bore and stroke (mm)	84x100	84x100	84x100	84x100	99x110	99x110	99x110	99x110	99x110	99x110	99x100
Rated engine speed (rpm)	2800	2800	2800	2800	2500	2500	2500	2500	2500	2500	2500
Max. torque (Nm)	143	188	183	208	314	314	383	314	314	383	383
Fuel tank capacity (L)	60.5	60.5	73.8	73.8	73.8	96.5	96.5	96.5	96.5	96.5	96.5
<b>Transmission</b>	Hydrostatic single reduction chain drive										
Travel speeds low range/high range (optional) (kph)	11.9/-	11.9/-	11.9/17.4	12.5/18.3	11.4/16.9	11.4/16.9	12.4/18.5	9.3/13.4	8.2/12.2	8.2/12.2	8.2/12.2
Drive pump control	Direct mechanical or Electro-hydraulic										
<b>Dimensions and weight</b>											
<b>A</b> - Max. lift height (bucket hinge pin) (mm)	2845	2845	3048	3073	3124	3287	3327	3124	3330	3215	3327
<b>B</b> - Height (mm)	1919	1919	1974	1998	1998	2002	2042	1998	2043	2043	2043
<b>C</b> - Length without attachment (mm)	2435	2435	2685	2685	2669	2993	3021	2669	2993	3016	2986
<b>D</b> - Length with bucket* (mm)	3028	3028	3352	3338	3292	3863	3652	3292	3631	3646	3624
<b>E</b> - Width (mm)	1518	1518	1678	1755	1755	1768	1930	1676	1930	1930	1930
<b>F</b> - Wheelbase (mm)	941	941	1128	1128	1128	1322	1322	-	-	-	-
<b>G</b> - Ground clearance (mm)	178	178	178	203	203	203	243	243	243	243	243
<b>H</b> - Dump height (mm)	2246	2246	2380	2405	2495	2615	2655	2495	2655	2602	2655
<b>I</b> - Dump angle (°)	40	40	52	52	40	55	48	40	55	38	55
<b>J</b> - Dump reach @ max. height (mm)	469	469	783	758	517	821	781	758	875	548	781
<b>K</b> - Angle of departure (°)	22	22	23	25	25	24	27	25	32	32	27
<b>L</b> - Rollback angle (bucket on ground) (°)	26	26	35	34	31	33	33	31	33	30	33
Operating weight (kg)	2300	2505	2832	2930	3160	3740	4136	3720	4370	4536	4581
<b>Performance specs</b>											
Rated Operating Capacity (ROC)* (kg)	590	725	818	905	905	1270	1545	1225	1450	1540	1723
Rated Operating Capacity (ROC) with counterweights* (kg)	635	770	863	950	950	1400	1680	-	-	-	-
Tipping load (kg)	1179	1455	1633	1814	1814	2540	3090	2449	2900	3080	3447
Lift cylinder breakout force (kN)	12.7	14.7	11.7	15.3	20.3	27.3	30.8	27.0	21.5	34.5	27.2
Bucket cylinder breakout force (kN)	18.6	23.4	24.7	32.5	32.3	38.3	41.5	32.3	32.7	38.7	32.7
Chassis design	wheels	wheels	wheels	wheels	wheels	wheels	wheels	tracks	tracks	tracks	tracks
Boom design	Radial Lift	Radial Lift	Super Boom	Super Boom	Radial Lift	Super Boom	Super Boom	Radial Lift	Super Boom	Radial Lift	Super Boom

- Not available \* 50% of tipping load All figures are based on a machine with standard tyres and standard bucket

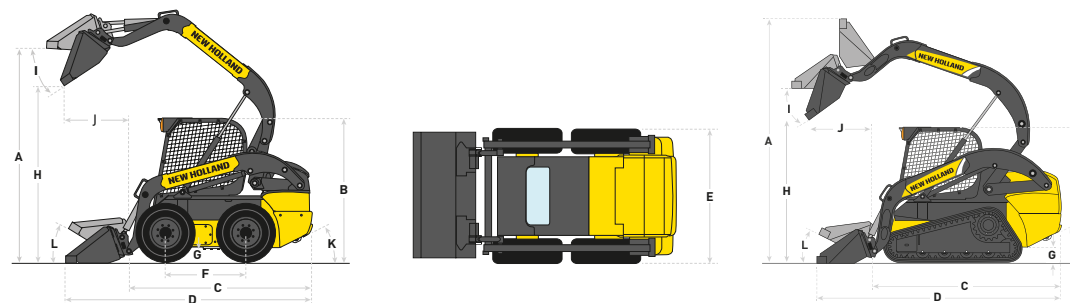

## Mini Crawler Excavators

### E17C - E18C - E26C - E30C - E33C - E37C - E57C - E60C



Models		E17C	E18C	E26C	E30C	E33C	E37C	E57C	E60C
<b>Engine</b>									
Power	[kW/hp[CV]]	12.5/16.8	12.5/16.8	18.5/24.8	18.5/24.8	18.2/24.4	18.2/24.4	49.9/66.9	48.3/64.7
Displacement	[cm³]	898	952	1261	1261	1642	1642	3319	3319
Torque	[Nm / rpm]	54 / 1900	53 / 1600	81 / 1600	81 / 1600	94 / 1200	89 / 1200	235 / 1550	235 / 1560
<b>Hydraulics system</b>									
Max. operating pressure	[Bar]	210	210	220	220	230	230	220	220
Short radius design		●	-	●	●	●	●	-	medium SR
Hydraulic flow delivery	[l/min]	2 x 18.8	2 x 17.0	2 x 27.6	2 x 27.6	2 x 37.4	2 x 37.4	2 x 57.8	2 x 55
Travel speed (High)	[kph]	4.3	4.1	4.5	4.3	4.2	4.4	4.1	3.9
Variable width undercarriage		●	●	-	-	-	-	-	-
<b>R</b> - Rear end swing radius	[mm]	645	1065	775	775	775	870	1650	1080
<b>H</b> - Track belt width	[mm]	230	230	250	300	300	300	380	380
<b>J</b> - Track length on ground	[mm]	1590	1590	1910	1970	2130	2130	2530	2530
<b>K</b> - Center distance of tumblers	[mm]	1230	1230	1490	1550	1700	1700	1990	1990
<b>L</b> - Blade max. height above ground	[mm]	285	170	330	370	400	375	390	200
<b>M</b> - Blade max. dig depth	[mm]	225	240	380	450	435	390	590	700
<b>N</b> - Blade width	[mm]	990 - 1300	980 - 1250	1500	1550	1550	1740	1920	1980
<b>O</b> - Blade height	[mm]	250	250	300	330	330	370	350	350
<b>Digging Performance</b>									
Dipperstick (Short arm / Long arm)	[mm]	960 / 1120	960 / 1120	1120 / 1350	1120 / 1350	1300 / 1600	1300 / 1600	1600 / 1900	1480 / 1900
<b>E</b> - Max. digging depth	[mm]	2200 / 2350	2250 / 2400	2420 / 2645	2500 / 2720	3035 / 3285	3135 / 3440	3820 / 4060	3570 / 3990
Bucket Breakout force (Short arm / Long arm)	[kN]	15.5	15.1	21.1	20.1	30.7 / 30.9	30.7 / 30.9	42.4	40.9
Dipperstick Breakout force (Short arm / Long arm)	[kN]	8.5 / 7.6	9.4 / 8.5	14.6 / 12.8	13.7 / 12.4	19.5 / 16.9	19.5 / 16.9	31.9 / 28.7	26.5 / 22.4
<b>R'</b> - Min front slew radius (Cab/Canopy)	[mm]	1570	1615	1970	2055 / 2090	2290	2330	2350	2420
<b>D</b> - Max. reach	[mm]	3900 / 4030	3970 / 4120	4480 / 4680	4650 / 4860	5180 / 5470	5315 / 5605	6150 / 6400	6150 / 6480
<b>F</b> - Max. dump height (Short arm / Long arm)	[mm]	2570 / 2670	2550 / 2660	2930 / 3030	2890 / 3030	3275 / 3335	3425 / 3615	4050 / 4180	3930 / 4100
<b>G</b> - Max. digging height (Short arm / Long arm)	[mm]	3580 / 3680	3670 / 3780	4150 / 4235	2500 / 2720	4650 / 4840	4810 / 5010	5780 / 5920	5680 / 5850
<b>Dimensions</b>									
<b>C</b> - Max. width (tracks extended / retracted)	[mm]	990 / 1300	980 / 1250	1500	1550	1550	1740	1920	1980
<b>A</b> - Max. length (Short arm / Long arm)	[mm]	3480 / 3510	3840 / 3870	4030 / 4100	4180 / 4220	4640 / 4690	4790 / 4665	5900 / 5990	5600 / 5720
<b>B</b> - Max. height	[mm]	2320	2300	2500	2500	2500	2500	2550	2550
<b>Operating Weight</b>									
Operating Weight (Cab/Canopy)	[kg]	- / 1770	1890 / 1720	2650 / 2500	3000 / 2890	- / 3150	3760 / 3620	5580 / -	5980

● Standard - Not available

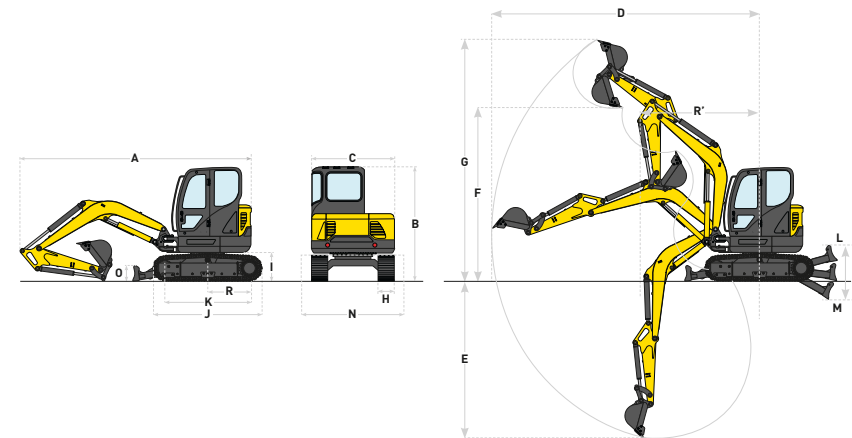

# Backhoe Loaders

## B100C - B110C - B115C



Models	B100C TC	B110C TC	B115C TC			
<b>Engine</b>	F5H	F5H	F5H			
No. of cylinders/Aspiration/Valves/Emission level Tier-Stage	4/T/2/4B-4	4/T/2/4B-4	4/T/2/4B-4			
Capacity (cm³)		3400				
Bore and stroke		99x110				
Rated engine power ISO TR14396 - ECE R120 (kW/hp[CV])	73/98	83/111	83/111			
Fuel tank capacity (L)		132				
<b>Hydraulics</b>						
Standard pump flow @2200rpm / Optional MegaFlow™ pump flow @2200rpm (lpm)	156 / 6 to 165	6 to 165 / -	6 to 165 / -			
<b>Transmission</b>						
Powershuttle transmission (40kph)	●	●	-			
Powershift transmission (40kph)	○	○	●			
<b>Cab</b>						
Noise level - internal / external (dB[A])	77 / 102	77 / 103	77 / 103			
<b>Operating weight</b>						
With standard backhoe and 4-in-1 bucket (kg)	8120	8120	8370			
With extendible backhoe and 4-in-1 bucket (kg)	8800	8800	9100			
<b>Overall dimensions</b>						
B - Wheelbase (mm)	2175	2175	2200			
E - Overall length (mm)	5928	5928	5945			
F - Height to top of boom (mm)	3875	3825	3930			
P - Cab height (mm)	2940	2940	3000			
I - Overall width including bucket (mm)	2250	2250/2400	2400			
K - Overall width (mm)	2325	2325	2325			
<b>Loader specifications</b>						
Maximum loader breakout force (daN)	6544	6544	5413			
Lifting capacity to maximum height (kg)	3450	3553	3075			
L - Digging depth (mm)	120	120	127			
G - Hinge pin height (mm)	3458	3458	3478			
H - Maximum dump height under bucket at 45 ° (mm)	3218	3218	2674			
<b>Backhoe specifications</b>	<b>retracted</b>	<b>extended</b>	<b>retracted</b>	<b>extended</b>	<b>retracted</b>	<b>extended</b>
Bucket Breakout force max. digging force (daN)	-	5971	-	5971	-	5971
Dipper breakout force max. digging force (daN)	3555	2593	3555	2593	3350	2389
U - Dumping height (mm)	3832	4557	3832	4557	3941	4662
V - Digging reach at ground level (mm)	5448	6542	5448	6542	5433	6529
Z - Digging depth (mm)	4600	5785	4600	5785	4489	5673

● Standard ○ Option - Not available

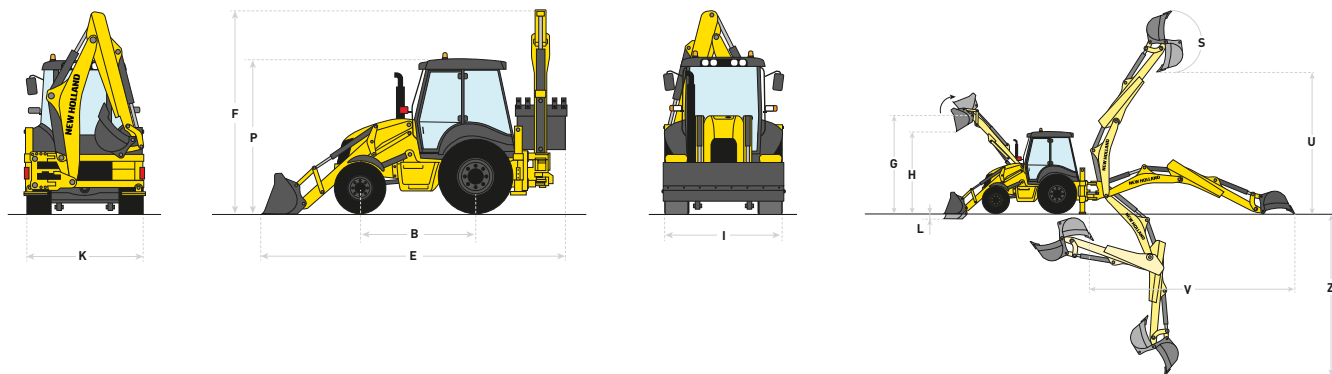



# Wheel Loaders

## W110D - W130D - W170D - W190D



Models	W110D								W130D								W170D								W190D							
	Z-BAR BUCKET				LONG REACH BUCKET				Z-BAR BUCKET				LONG REACH BUCKET				Z-BAR BUCKET				LONG REACH BUCKET				Z-BAR BUCKET				LONG REACH BUCKET			
	1.9m³		1.7m³ w/QC		1.7m³		1.7m³ w/QC		2.3m³		2.0m³ w/QC		2.14m³		2.0m³ w/QC		2.7m³		2.4m³ w/QC		2.5m³		2.4m³ w/QC		3.4m³		3.2m³ w/QC		3.2m³		3.2m³ w/QC	
edge	teeth	edge	teeth	edge	teeth	edge	teeth	edge	teeth	edge	teeth	edge	teeth	edge	teeth	edge	teeth	edge	teeth	edge	teeth	edge	teeth	edge	teeth	edge	teeth	edge	teeth	edge	teeth	
<b>Engine</b>	NEF N45								NEF N67								NEF N67								NEF N67							
No. of cylinders/Aspiration/Valves/Emission level Tier-Stage	4/T/4/4B-4								6/T/4/4B-4								6/T/4/4B-4								6/T/4/4B-4							
After Treatment System	HI-eSCR								HI-eSCR								HI-eSCR								HI-eSCR							
Capacity [cm³]	4500								6700								6700								6700							
Max. horsepower - ISO TR14396 - ECE R120 [kW/hp(CV)]	106 / 144 @ 1800rpm								128 / 174 @ 1800rpm								145 / 197 @ 2000rpm								172 / 234 @ 1800rpm							
Max. torque ISO TR14396 [Nm]	608 @ 1600rpm								730 @ 1600rpm								950 @ 1600rpm								1184 @ 1300rpm							
Diesel capacity [L]	189								248								246								288							
<b>Hydraulics</b>	Pilot control with single joystick or two levers																															
Control	Pilot control with single joystick or two levers																															
Pump type	Variable displacement pump								Variable displacement pump								Tandem variable displacement pump								Tandem variable displacement pump							
Pump output [lpm]	134								171								206								240							
<b>Transmission</b>	All wheel drive																															
4-Speed Powershift	●								●								●								-							
5-Speed Powershift with Ecoshift	-								○								○								●							
Maximum speed [kph]	40								40								45*								40*							
<b>Cab</b>																																
Noise level in the cab - LpA - [ISO 6595/6396/3744] [dB(A)]	68								69								69								68							
Noise level outside - LwA - [SAE J88 SEP80] [dB(A)]	101								101								101								104							
Bucket payload [m³]	2.1	1.98	1.75	1.66	1.88	1.78	1.75	1.66	2.3	2.3	2.03	1.93	2.1	2.1	2.03	1.93	2.68	2.68	2.71	2.61	2.45	2.45	2.71	2.61	3.3	3.2	3.2	3.1	3.2	3.1	3.2	3.1
Bucket outside width [mm]	2497	2540	2497	2540	2497	2540	2497	2540	2497	2540	2497	2540	2497	2540	2497	2540	2712	2726	2712	2726	2494	2510	2712	2726	2950	2990	2950	2990	2950	2990	2950	2990
Tipping load [kg]	8229	8297	7896	8039	7153	7219	6781	6905	10030	10099	9497	9649	8626	8692	8011	8139	11741	11766	10271	10382	10019	10046	8708	8797	13620	13640	11980	12040	11030	11060	9560	9600
Tipping load at full turn (40°) [kg]	7053	7121	6741	6874	6115	6181	5764	5880	8481	8551	7965	8103	7283	7349	6688	6805	9528	9552	8259	8350	8129	8156	6969	7044	10980	11000	9480	9540	8880	8900	7500	7540
Breakout force [kg]	7599	8342	7019	7664	8130	8967	7016	7661	10099	10973	9448	10175	11548	12645	9475	10201	14599	15710	12116	12928	14593	15704	11991	12799	15040	16030	12800	13540	15700	16730	13040	13790
Lift capacity from ground [kg]	8874	9005	7898	8440	8925	8984	8521	8673	9859	9992	8709	9243	11515	11577	10822	10949	13706	13735	12439	12558	11451	11487	10317	10406	17720	17860	13310	13590	13900	13920	12400	12450
<b>B</b> - Hinge pin height [mm]	3605	3606	3605	3605	3985	3985	3984	3985	3833	3833	3832	3832	4258	4258	4256	4256	3976	3976	3974	3974	4371	4371	4369	4369	4120	4120	4120	4120	4560	4560	4560	4560
<b>H</b> - Height to top of cab [mm]	3275	3275	3275	3275	3275	3275	3275	3275	3384	3384	3384	3384	3384	3384	3384	3384	3378	3378	3378	3378	3378	3378	3378	3378	3460	3460	3460	3460	3460	3460	3460	3460
<b>L</b> - Overall length [mm]	6838	6937	6930	7030	7111	7207	7272	7371	7469	7567	7527	7633	7754	7852	7935	8041	7659	7807	7839	7987	8017	8164	8198	8344	8080	8200	8260	8380	8540	8660	8750	8870
<b>R</b> - Turning radius (Outside of Tires) [mm]	5017	5017	5017	5017	5017	5017	5017	5017	5223	5223	5223	5223	5223	5223	5223	5223	5748	5748	5748	5748	5748	5748	5748	5748	6000	6000	6000	6000	6000	6000	6000	6000
Machine operating weight with XHA2 (L3) tyres [kg]	11098	11045	11303	11250	11192	11138	11431	11377	12853	12799	13305	13252	12983	12930	13482	13428	14767	14748	15291	15272	14904	14882	15494	15475	18200	18180	19270	19250	18440	18420	19540	19520
<b>W</b> - Width [mm]	2478	2478	2478	2478	2478	2478	2478	2478	2478	2478	2478	2478	2478	2478	2478	2478	2558	2558	2558	2558	2558	2558	2558	2558	2830	2830	2830	2830	2830	2830	2830	2830

● Standard ○ Option - Not available \* where local homologation allows

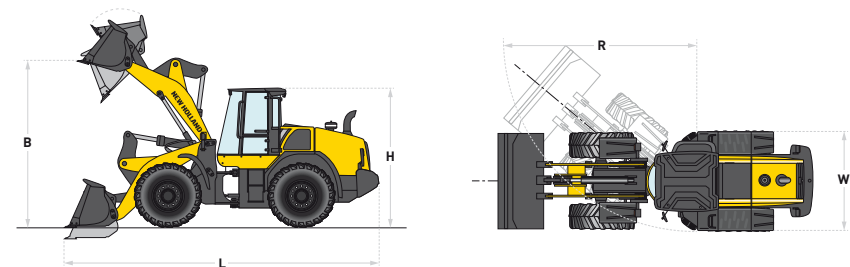

# High performance, wide choice.

A wide variety of high performance attachments are available to help you get the most out of your investment. Please contact your local dealer for further information.



# Satisfaction. Guaranteed.

Buying a New Holland machine is just the beginning of a partnership. A vast wealth of local and regional knowledge means that you can rely on a partner who can offer you ultimate peace of mind. Accompanying you every step of the way are a highly trained and skilled team of professionals, who are dedicated to offering you just what you need to grow your business. In the dealership, 24 hours a day, 365 days a year, New Holland people are always willing to go the extra mile to guarantee you complete satisfaction.



## CNH Industrial Parts & Service

All New Holland official dealers stock a full range of parts for rapid delivery and reduced downtime. Approved accessories are also available to optimise your machines' performance in all conditions.



## CNH Industrial Capital

CNH Industrial Capital, the financial services company of New Holland, is well established and respected within the agricultural sector. Advice and tailored finance packages are available to meet your specific needs. CNH Industrial Capital offers you the peace of mind that comes from dealing with a specialist in agricultural financing.



## New Holland Top Service

For ultimate peace of mind, Top Service offers you around the clock assistance. No matter when, no matter where, simply call the toll free numbers for assistance, enjoy express parts delivery with a 100% total satisfaction guarantee.

AT YOUR OWN DEALER



[www.newholland.com/uk](http://www.newholland.com/uk) - [www.newholland.com/ie](http://www.newholland.com/ie)

