

## B-SERIES

**B115<sub>B</sub> B110<sub>B</sub> B90<sub>B</sub>**



**BUCKET CAPACITY  
ENGINE POWER**

**B115B - B110B**  
UP TO 1,2 M<sup>3</sup> BUCKET  
110 HP

**B90B**  
1,0 M<sup>3</sup> BUCKET  
100 HP



**BUILT AROUND YOU**

# B115B/B110B/B90B

## HIGH OPERATING COMFORT

Class-leading operator environment

## LOW COST OF OWNERSHIP

Fuel efficient  
Easy to maintain



**BEST IN CLASS  
PRODUCTIVITY**

10% more power than  
competitive machines

**ENVIRONMENTAL  
EFFICIENCY**

10% reduction in fuel  
consumption and emissions

# BI15B/BI10B/B90B

## ENVIRONMENTAL CONCERN

### LESS FUEL CONSUMPTION RESULTS IN LOWER ENGINE EMISSIONS



The 4.5 litre turbocharged engines for the new machines are provided by FPT Industrial, a world-wide leader in the design, production and sale of powertrains for industrial applications, supplying among others CNH Industrial brands such as New Holland Construction and Iveco.

The Variable Displacement Pump hydraulic system is standard on BI10B and above, contributing to a 10% fuel saving and a rapid return on investment.

#### **LOW NOISE LEVELS FOR URBAN JOBSITES**

- Reduced emission Tier III engine
- Low external noise levels
- New Holland CB90S is a silenced hydraulic breaker especially designed for backhoe loader use
- Rubber pads under the stabilizers reduce ground damage in sensitive operating conditions

# BEST IN CLASS PRODUCTIVITY



Thanks to the curved arm design, load sensing hydraulics and extensive backhoe reach



# BI15B/BI10B/B90B

## BEST IN CLASS PRODUCTIVITY



- Maximize bucket filling with Powershift transmission and standard kick down function
- Easy leveling thanks to loader float function controlled from the joystick
- Shorter cycle times thanks to Automatic Return-to-dig button
- No loader arm bounce and increased bucket retention with optional Glide Ride
- Excellent traction in the worst conditions thanks to a 100% lockable differential, or a limited slip differential on the BI15B



## MORE POWER



## SMOOTH CONTROL UNDER LOAD WITH POWERSHIFT

Available on B110B and B115B, the Powershift transmission provides maximum operator comfort.

In “full automatic mode” the transmission will auto-shift either up or down the gears, depending on speed and load, improving cycle times and simplifying road travel.

For less sophistication, you can opt for our robust PowerShuttle transmission that is available on all models. It is the standard transmission on B90B.

## MINIMIZED DOWNTIME



Hydraulic side shift (option): Fast and accurate positioning of the boom without damaging the ground



Excellent lighting for night work



4 front working lights and 4 rear working lights (except B90B: 2 front + 2 rear)

# BI15B/BI10B/B90B

**OPERATOR COMFORT MATTERS,  
WELCOME ON BOARD!  
ROOMY CAB WITH EASY ACCESS**

## **SIMULTANEOUS CONTROL**

All loader and bucket controls are located on the joystick

## **DELUXE OPERATOR'S SEAT**

- Adjustable comfortable armrest
- Pneumatically height adjustable suspension seat

## **EASY CLEANING**

- Removable floor covering and flat cab floor make cleaning easier

## **STORAGE ROOM**

- Cup holder
- Wider glove box

## **EXCELLENT VENTILATION**

- Partial or full opening of both front and rear side windows
- Cab fan (option)
- Standard heater or air conditioning (option)



## ALL CONTROLS UNDER YOUR HAND



## FULLY ADJUSTABLE WORKING POSITION

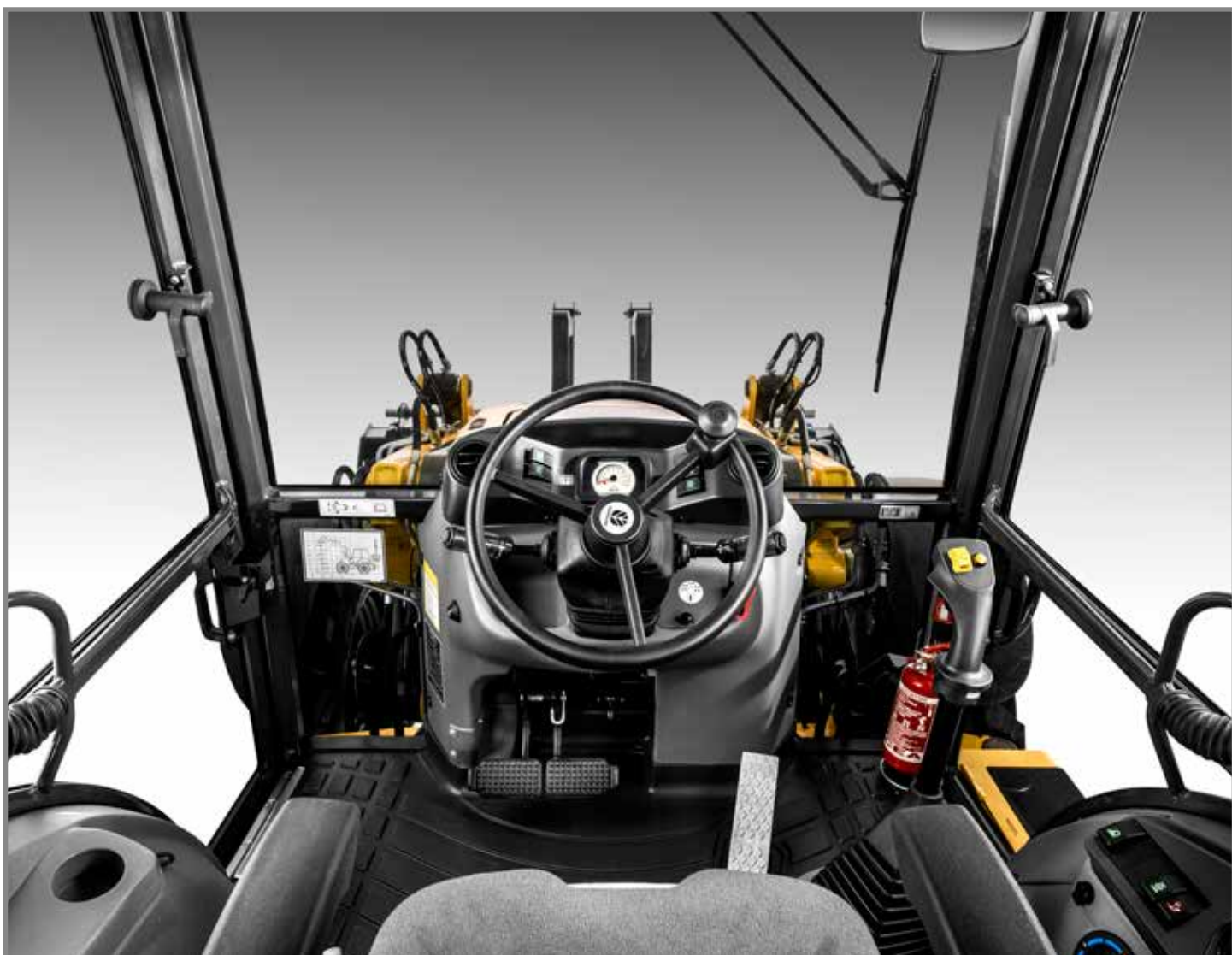

## QUIET WORKING ENVIRONMENT:

Cab interior 77 dB / exterior 103 dB

# BI15B/BI10B/B90B

## LOW COST OF OWNERSHIP



**10% Fuel saving**

### A SIGNIFICANT COST SAVING

If your New Holland machine is used for 800h/year, we estimate that our new hydraulic system, including the Variable Displacement Pump, will result in average savings of up to 1000 \$/year



**Vandal proof**

### PROTECT YOUR INVESTMENT ON SITE

- Secure hydraulic oil cap-breather
- Battery box is locked with a key
- Engine hood is lockable with a key
- An anti-theft device is available as option



**Smart design**

### DRIVING LIGHT PROTECTION

Rear driving lights have 2 positions:

- transport position: on the stabs
- working position: on the cab, (see picture) so that they are completely protected

### WINDOW OPENING

Ventilation is optimized in the cab thanks to the partial or total opening of the side windows and the fully retractable rear screen





## Maintenance friendly

### BEST IN CLASS ACCESSIBILITY

Tilting engine hood provides excellent ground level access to the engine and service points.



### CENTRAL SERVICE POINT LOCATION

Daily check and fill points are accessible from ground level for time saving.

On the machine's left side, just above the fuel tank, you can easily reach:

- the hydraulic pressure check points
- steering circuit
- pilot control

All grouped together for time and cost reduction whilst improving efficiency, durability and performance



### EASY DIAGNOSIS

Rapid engine diagnosis is possible with the New Holland Electronic Service Tool

### NO SEPARATE BRAKE FLUID

Hydraulic oil is used as the brake fluid, so no need to use separate tank and no risk of using the wrong fluid



### PROTECTED BATTERY EASY TO REACH

The Battery is easily reached in the tool box located on the right side, underneath the cab. By removing one panel it is simple to access both the battery and the master switch.



# SERVICE PLUS





## THE NEW HOLLAND DEALER: YOUR PROFESSIONAL PARTNER

Your success starts with world-class New Holland machinery and attachments. Your New Holland dealer will help you work smarter and faster by selecting equipment that delivers performance and operator comfort. Your dealer has the knowledge and experience necessary to help you choose the right attachments so you can...

- **Work faster and extend equipment life.**
- **Increase machine utilization.**
- **Increase your capabilities.**

Let your New Holland dealer service your machine on the jobsite. You'll be back on the job faster. Advantages include...

- **Responsive job site service to keep your equipment running.**
- **Increase machine uptime.**
- **Certified service staff and improved parts availability.**

## PARTS

When you're looking for superior parts options to maximise the performance and lower the operating costs of your New Holland machinery, turn to CNH Original Parts to keep you equipped for success.

CNH Original Parts fit better, install faster and last longer and in an industry where "high impact" and "heavy lifting" are the norm, the smallest mechanical differences can lead to big problems.

CNH Original Parts from New Holland are manufactured from superior materials and specifically designed for New Holland to continually and reliably withstand the punishment of everyday construction. So steer clear of mechanical problems and future breakdowns, by choosing CNH Original Parts from New Holland. They're the only parts that are field-tested and proven to keep your New Holland equipment performing its best.

## SERVICE. RELY ON NEW HOLLAND TO DELIVER FOR YOU

Your commitment to your operation is evident every day, but that doesn't minimise the enormous pressure you face to reduce operating costs and improve productivity. So when you're on the job, make sure you have top-notch service and support of New Holland behind you every step of the way. With our factory trained technicians, you can ensure that top-notch service professionals are working on your maintenance needs, so you can focus on your business and the big job challenges ahead, not on the tasks of servicing your equipment.

With your New Holland Service, you get more than mere oil changes. A New Holland Service ensures your New Holland equipment receives a thorough service that meets all requirements of its service schedules and properly maintains it for the day-in, day-out punishment of construction work.

Don't give another thought to time-consuming maintenance tasks. Simply rest easy and make certain that your service needs are taken care of by a New Holland factory trained technician.





When the unexpected occurs, you need to know your equipment is protected. At New Holland we understand the importance of your machinery being in good working order when it counts. Service Plus is designed to help keep your equipment working well beyond the manufacturer's base warranty period while taking away the concerns of the cost and inconvenience of mechanical failure.

**WHAT ARE THE ADVANTAGES OF SERVICE PLUS?**

**PEACE OF MIND**

Provides protection beyond the Manufacturer's Base Warranty Period.

**FLEXIBLE OPTIONS**

Plans can be customised to meet individual needs.

**DEPENDABLE SERVICE**

Eligible repairs completed by an authorised New Holland Dealership and their trained service technician's using genuine OEM parts & lubricants.

**TRANSFERABLE PROTECTION**

New Equipment Plans may be transferred to a new owner at no charge

**• STANDARD PROTECTION PLAN 3 Year / 3000 Hour**

Additional years/hours can be purchased. Please contact your local New Holland dealer for further information.

# STANDARD SERVICE PLUS PROTECTION PLAN CONSTRUCTION EQUIPMENT MASTER PARTS SCHEDULE

This plan provides coverage for the components listed below when a failure occurs due to a defect in material or workmanship, and may provide coverage for additional components not listed when the damage is caused by or resulting from a covered failure of a listed component.

## PREMIER COMPONENTS COVERED

ENGINE AND ALL INTERNAL LUBRICATED COMPONENTS WITHIN	TRANSMISSIONS/AXLES/HYDROSTATICS	ELECTRICAL	HYDRAULICS
Accessory Gears	Axle Housing	Alternator	Accumulator And Related Relief Valve
Air Intake Hose	Axle Shaft	Gauges	Brake Accumulator
Camshaft	Clutch Discs (Wet Only)	Horn	Brake Pressure Sensor
Camshaft Bearings	Clutch Plates (Wet Only)	Indicators	Brake Pump, Brake Valve
Camshaft Drive Gear	Control Rods	Instruments	Differential Lock Valve
Catalytic Converter	Counter Shaft Clutch	Electronic Joysticks	Fan Pumps And Motors
Charge Air Cooler	Differential Housing	Electric Motors	Hydraulic Cylinders
Cold Start Enrichment Systems	Differential Pinion Gear / Ring Gear	Factory Installed Telematics	Hydraulic Hoses and Piping
Connecting Rods & Bearings	Drive Axle Hub	Sensors	Hydraulic Motors
Crankshaft Bearings & Gear	Drive Shaft Support Bearing	Solenoid Valves	Hydraulic Oil Coolers
Crankshaft Including Front And Rear Crankshaft Seals	Drive Shaft with Universal Joints	Starter And Starter Solenoid	Hydraulic Pumps
Cylinder Heads/ Head Gaskets	Electronic Transmission Controller and Valve	Switches	Hydraulic Reservoir
Cylinder Liners	Enclosed Oil Immersed Chains and Sprockets	Traction Control System	Hydraulic Valves
Diesel Exhaust Fluid Tank and Dispensing System	External Oil Lines	Voltage Regulator	Internal O-Rings and Bonded Washers
Diesel Particulate Filter	Filler Tubes (Transmission)	Wiring Harnesses	Pilot Control
EGR System Manifold	Final Drive Pinion	Wiring Harnesses Exclusions	Pressure Reducing Valves
Electronic Engine Control Module	Final Drive Planetary Gears	Rubbing, Chafing, Loose Or Corroded Connections	Unloading Valves
Engine Block	Front Wheel Drive Sensors	<b>FACTORY INSTALLED HEAT AND AIR CONDITIONING</b>	<b>STRUCTURAL</b>
Engine Mounts And Supports	Hydraulic Drive / Travel Motor	Accumulator	Backhoe Booms
Engine Oil Cooler	Hydraulic Drive Pump	Clutch	Backhoe/Excavator Dipper Sticks
Engine Speed Controls, Linkages, and Cables	Hydraulic Transmission-Control Valve	Compressor	C Frame
Exhaust Manifold and Muffler	Hydrostatic Motor	Condenser	Car Body
Fan And Fan Drive	Hydrostatic Transmission Charge Pump	Dryer	Chassis
Filter Mount	Hydrostatic Transmission Pump	Evaporator	Circle Frame
Flywheel, Ring Gear	Hydrostatic/Hydraulic Pump Drives	Expansion Valve	Engine Frame
Front And Rear Engine Covers And Seals	Internal Lubricated Clutch Housings	Heater Core	Equipment Frame
Front Damper	Internal Transmission Control Linkage	Hoses	Excavator Booms
Fuel Lines	Internal Wet Service Brakes	Pulley	Falling Object Protection Structure (FOPS)
Fuel Tank	MFWD Axle/Differential Assembly including Driveshaft and U Joint	Seals & Gaskets	Forklift Masts
Fuel Transfer Pump & Gasket	Planetary Gear Carrier	Temperature Control Programmers and Valves	Inner and Outer Dipper Arms of the Extendable Boom (Backhoe Loader)
Injection Pump	Pneumatic Valves	<b>OPERATOR AREA</b>	Main Frame
Injectors	Rotary Hydraulic Manifold	Covers and Panels	Rollover Protection Structure (ROPS)
Intake and Exhaust Manifold And Gaskets	Splitter Drive/Drop Box	Exterior/Interior Door/Panel Latches, Hinges & Struts	Swing Frame
Oil Filler Tube	Steering Clutches (Wet)	Exterior/Interior Moldings	Swing Tower Castings (Backhoe Loader)
Oil Lines	Swing Motor And Swing Gear Box	Knobs for Switches and Handles	Track Frame
Oil Pan And Gasket	Torque Converter	Mirrors	Wheel Loader/Skid steer Loader Arms
Oil Pump	Torque Converter Pump	Seat Frame & Suspension	
Pistons & Rings	Transfer Drive		
Pre-Cleaner/Air Cleaner Housing	Transmission Case		
Pressure/Temperature Sensors & Sending Units	Transmission Gears, Bearings, & Shafts		
Pulleys	Transmission Pump		
Radiator	Travel & Swing Sections (only) Of Main Control Valve		
Rocker Arm Assembly	Travel Control Valve		
Selective Catalytic Reduction System	Turntable Bearing		
Thermostats	Undercarriage Roller And Idler Seals And Bearings		
Timing Gears	Undercarriage Tensioners		
Turbocharger And Gasket	<b>UNDERCARRIAGE EXCLUSIONS:</b>		
Valve Cover And Gasket	Sprocket, Tracks, Pads, Bolts, Chains, Or Any Failure Due To Wear, Or Breakage Caused By Wear		
Water Piping			
Water Pumps			

# BI15B/BI10B/B90B



## BI15B

## MAIN FEATURES

## SPECIFICATIONS

### BI15B

4 equal-sized wheel steer  
1.2 m<sup>3</sup> bucket  
112 hp  
Powershift Transmission (standard)  
Pilot Control  
4.5 litre FPT Industrial engine turbocharged,  
common rail injection  
110 hp @ 2200 rpm / 520 Nm @ 1400 rpm

<b>HYDRAULICS</b>	
Type of pump	Variable Displacement
Maximum flow	6 to 156 l/min @ 2200 rpm
Maximum pressure level	205 bars
<b>BATTERY</b>	12V 95Ah, 900 A (SAE) - 120 A
<b>OPERATING WEIGHT</b>	
- with standard backhoe and 6-in-1 bucket	8870 kg
- with Extendible Backhoe and 6-in-1 bucket	9100 kg
<b>TURNING RADIUS</b> (front tyres 12.5/80-18, wheel not braked, 4WD engaged)	
- at ext. edge of front tires	4300 mm
- at bucket corner	5600 mm
<b>AXLES, TYRES &amp; BRAKE</b>	
Brakes:	Power Brake with 2472 cm <sup>2</sup> friction area
Tires can be multipurpose, hard soil specific or soft soil specific	
Steering mode	2WS (standard operation), 4WS (agile and fast operation) and crab (confined areas)
Tires	28" front with 28" rear
Front axle with +/- 11° oscillation	Limited Slip Differential
<b>CAPACITIES</b>	
Fuel tank	135 l
Cooling system	24 l
<b>EMISSIONS</b>	
CO <sub>2</sub> emissions (g/kWh)	744
NO <sub>x</sub> emissions	3.6
HC emissions	0.1
CO emissions	1.3
PM emissions	0.13
NO <sub>x</sub> + NMHC emissions	3.7
<b>NOISE</b>	
Internal (dB(A))	77
External (dB(A))	103
<b>VIBRATION LEVELS</b>	
Upper limbs 2,5 m/s <sup>2</sup>	2.5
Abdomen 0,5 m/s <sup>2</sup>	0.5





# BI15B/BI10B/B90B

## SPECIFICATIONS

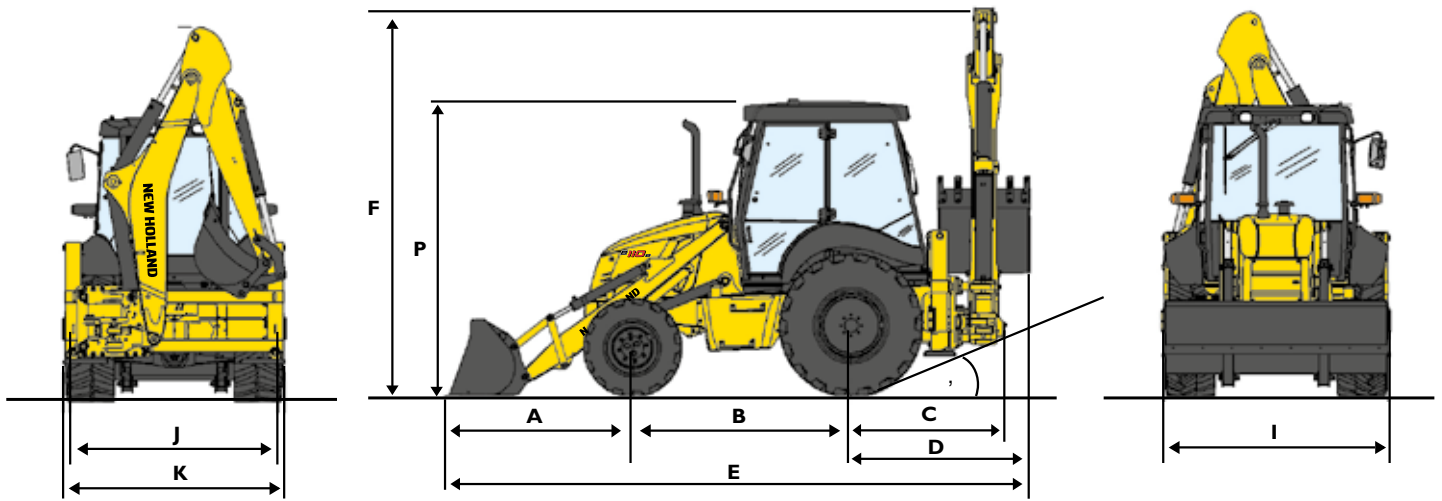

		BI15B		BI10B	
<b>OVERALL DIMENSIONS</b>					
<b>A</b>	Ground distance over front axle	mm	1965		1870
<b>B</b>	Wheelbase	mm	2200		2175
<b>C</b>	Pivot distance over rear axle	mm	1320		1320
<b>D</b>	Max distance over rear axle (with 915 mm backhoe bucket)	mm	1780		1780
<b>E</b>	Overall length	mm	5945		5825
<b>F</b>	Height to top of boom	mm	3930		3825
	Back ramp angle	°	22		23
<b>P</b>	Cab height	mm	2960		2940
<b>I</b>	Loader bucket width	mm	2400		2250/2400
<b>J</b>	Stabiliser width	mm	2250		2250
<b>K</b>	Overall width	mm	2325		2325
<b>LOADER SPECIFICATIONS</b>					
	Maximum loader breakout force	kN	TC version 74		TC version 66.5 STD version 69
	Lifting capacity to maximum height (without bucket)	kg	3550		3195 3550
<b>L</b>	Digging depth	mm	115		125 75
<b>M</b>	Bucket roll back angle on ground	°	45		46 40
<b>N</b>	Reach at full height	mm	825		813 785
<b>O</b>	Maximum operating height	mm	4480		4405 4330
<b>G</b>	Hinge pin height	mm	3490		3460 3500
<b>H</b>	Maximum dump height under bucket at 45°	mm	2650		2693 2780
<b>BACKHOE SPECIFICATIONS</b>					
	Bucket Breakout force	kN	retracted 64	extended	retracted 64 extended
	Dipper breakout force (Std Dipper/HED retracted)	kN	46.2		46.2
	Dipper breakout force (HED extended)	kN	32		32
<b>R</b>	Digging reach at max height	mm	2315	3130	2330 3190
<b>S</b>	Bucket rotation	°	204	204	204 204
<b>T</b>	Digging height	mm	5815	6475	5650 6305
<b>U</b>	Dumping height	mm	4090	4750	3930 4585
<b>V</b>	Digging reach at ground level	mm	5850	6810	5860 6815
<b>Z</b>	Digging depth	mm	4565	5600	4710 5750
	Bucket rotation	°	203		203

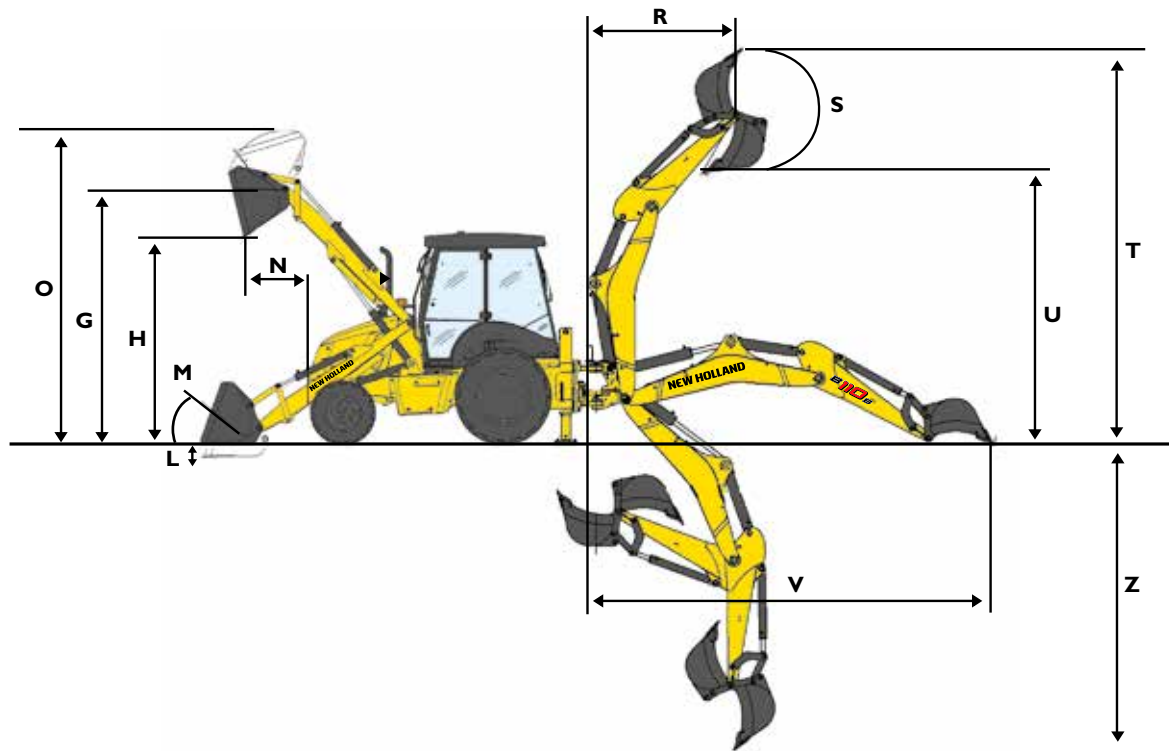

B90B				
<b>OVERALL DIMENSIONS</b>				
<b>A</b>	Ground distance over front axle	mm	1870	
<b>B</b>	Wheelbase	mm	2175	
<b>C</b>	Pivot distance over rear axle	mm	1320	
<b>D</b>	Max distance over rear axle (with 915 mm backhoe bucket)	mm	1780	
<b>E</b>	Overall length	mm	5825	
<b>F</b>	Height to top of boom	mm	3875	
	Back ramp angle	°	23	
<b>P</b>	Cab height	mm	2940	
<b>I</b>	Loader bucket width	mm	2250	
<b>J</b>	Stabiliser width	mm	2250	
<b>K</b>	Overall width	mm	2325	
<b>LOADER SPECIFICATIONS</b>				
	Maximum loader breakout force	kN	69	
	Lifting capacity to maximum height (without bucket)	kg	3550	
<b>L</b>	Digging depth	mm	75	
<b>M</b>	Bucket roll back angle on ground	°	40	
<b>N</b>	Reach at full height	mm	785	
<b>O</b>	Maximum operating height	mm	4330	
<b>G</b>	Hinge pin height	mm	3500	
<b>H</b>	Maximum dump height under bucket at 45 °	mm	2780	
<b>BACKHOE SPECIFICATIONS</b>				
	Bucket Breakout force	kN	64	
	Dipper breakout force (Std Dipper/HED retracted)	kN	46.2	
	Dipper breakout force (HED extended)	kN	32	
<b>R</b>	Digging reach at max height	mm	2330	3190
<b>S</b>	Bucket rotation	°	204	204
<b>T</b>	Digging height	mm	5650	6305
<b>U</b>	Dumping height	mm	3930	4585
<b>V</b>	Digging reach at ground level	mm	5870	6815
<b>Z</b>	Digging depth	mm	4710	5750
	Bucket rotation	°	203	

# PARTS AND SERVICE

The New Holland dealer network is, in itself, the best guarantee of continued productivity for the machines it delivers to its customers. New Holland service technicians are fully equipped to resolve all maintenance and repair issues, with each and every service point providing the high standards they are obliged to observe under New Holland's stringent quality guidelines. The New Holland global parts network ensures fast, reliable, replacement parts for less downtime, increased productivity and, of course, profitable operation for its customers.

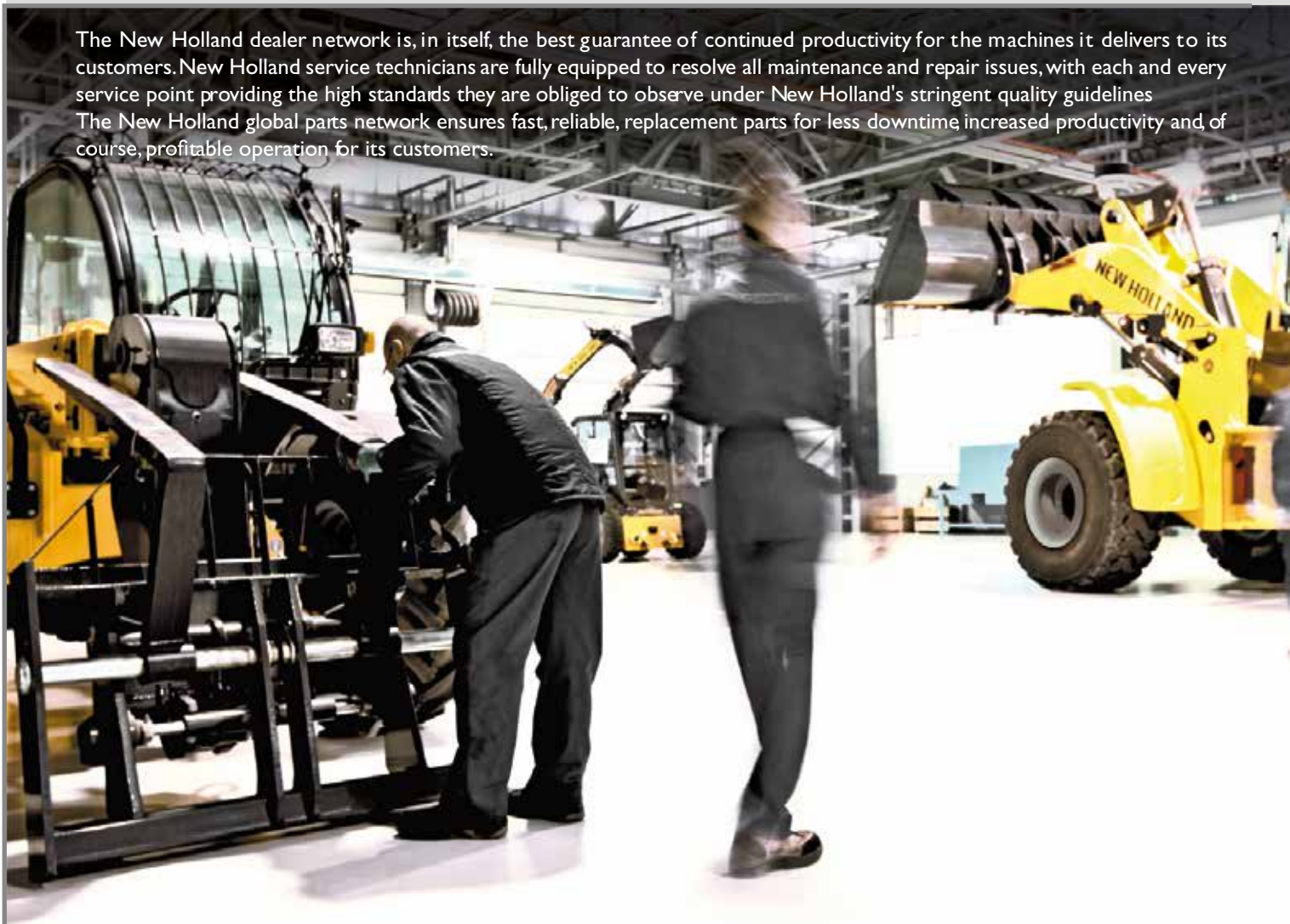

## AT YOUR OWN DEALERSHIP

The information contained in this brochure is intended to be of general nature only. The NEW HOLLAND CONSTRUCTION MACHINERY S.p.A. company may at any time and from time to time, for technical or other necessary reasons, modify any of the details or specifications of the product described in this brochure. Illustrations do not necessarily show products in standard conditions. The dimensions, weights and capacities shown herein, as well as any conversion data used, are approximate only and are subject to variations within normal manufacturing techniques.

Printed on recycled paper  
CoC-FSC 000010 CQ Mixed sources



ELEMENTAL  
CHLORINE  
FREE  
GUARANTEED



[www.newholland.com](http://www.newholland.com)

[creative-farm.it](http://creative-farm.it) - 07/17

