

Excellent driving stability, due to extremely low centre of gravity and high pivot rear axle

Large capacity industrial engines which deliver high torque at low speeds

Hydrodynamic drive unit provides efficient acceleration and direction changes

Cushion mounted drive unit isolates the operator from excessive vibration

Comfortable and safe operator's cab featuring exemplary ergonomics



DFG/TFG 316–320

Diesel and LPG forklifts with hydrodynamic drive units (1600, 2000 kg)

Jungheinrich hydrodynamic diesel and LPG forklift trucks give an incredible handling capacity in a variety of applications. The hydrodynamic drive performs especially well in medium to long distance operations and also ensures smooth shock-free polling away from rest.

Large capacity industrial engines generate high torque even at low speeds, giving the benefit of lower fuel consumption and noise.

These robust engines are specially designed for use in forklift trucks, ensuring high reliability and a long service life even for tough applications.

All the engines feature low emissions and comply with the future EU Directives. A closed-loop 3-way catalytic converter (TFG) and various particulate filter systems (DFG) are available as options.

The operator's cab has an ergonomic layout and is designed around the operator. This ensures safety, protects health and enables the operator to concentrate fully on his work whilst being in a relaxed & stress free environment. Overall this ensures maximum productivity for arduous shifts.

DFG/TFG 316–320

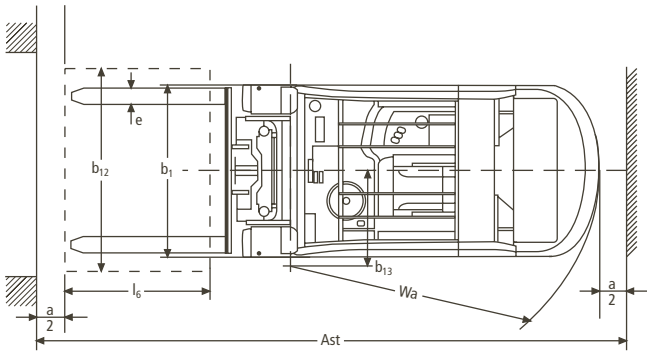
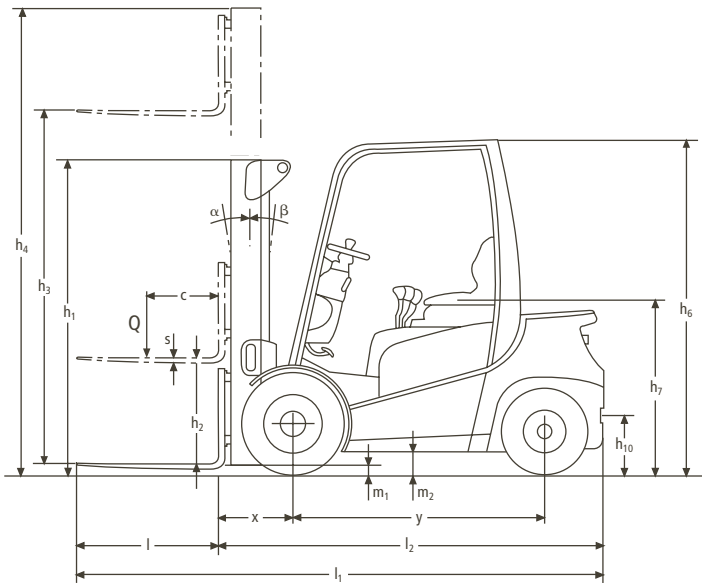

Capacity

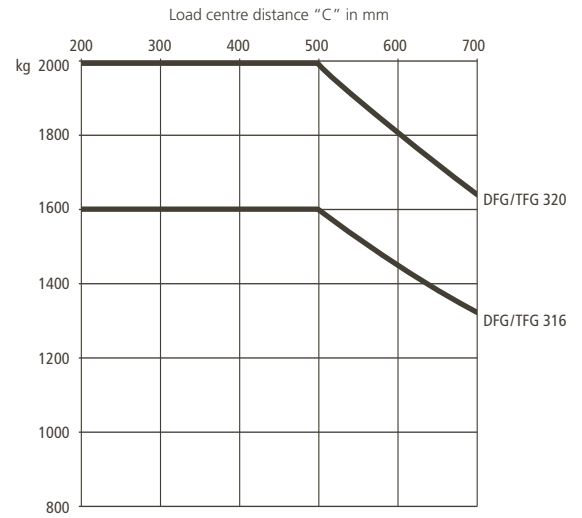

Designation	Mast table DFG/TFG 316–320					Capacity table (kg) c = 500 mm	
	Lift	Free lift	Closed mast height	Max. height	Tilt forward/backward	without sideshift, single solid tyres	
	h ₃ mm	h ₂ mm	h ₁ mm	h ₄ mm	α/β (°)	DFG/TFG 316	DFG/TFG 320
Two-stage ZT	2900	150	1985	3520	7/7	1600	2000
	3100	150	2085	3720	7/7	1600	2000
	3300	150	2185	3920	7/7	1600	2000
	3600	150	2335	4220	7/6	1600	2000
	3800	150	2435	4420	7/6	1600	2000
	4000	150	2535	4620	7/6	1600	2000
	4500	150	2835	5120	7/6	1600	2000
	5000	150	3085	5620	7/6	1500	1800
Two-stage ZZ	5500	150	3435	6120	7/5	1350	1500
	2900	1290	1940	3550	7/7	1600	2000
	3100	1390	2040	3750	7/7	1600	2000
	3300	1490	2140	3950	7/7	1600	2000
	3600	1640	2290	4250	7/6	1600	2000
	3800	1740	2390	4450	7/6	1600	2000
Three-stage DZ	4000	1840	2490	4650	7/6	1600	2000
	4200	1290	1940	4850	7/5	1600	2000
	4350	1340	1990	5000	7/5	1600	2000
	4500	1390	2040	5150	7/5	1600	1700
	4800	1490	2140	5450	7/5	1600	1600
	5000	1565	2215	5650	7/5	1600	1600
	5500	1740	2390	6150	7/5	1350	–
	6000	1940	2590	6650	7/5	1200	–
6500	2190	2840	7150	7/5	1000	–	

Technical Data in line with VDI 2198 as at: 06/2010

Identification	1.1	Manufacturer (abbreviation)	Jungheinrich	Jungheinrich	Jungheinrich	Jungheinrich	1.1	
	1.2	Manufacturer's type designation	DFG 316	TFG 316	DFG 320	TFG 320	1.2	
	1.3	Drive	diesel	LPG	diesel	LPG	1.3	
	1.4	Type of operation	seated	seated	seated	seated	1.4	
	1.5	Load capacity/rated load	Q (t)	1.6	1.6	2	2	1.5
	1.6	Load centre distance	c (mm)	500	500	500	500	1.6
	1.8	Load distance, centre of drive axle to fork	x (mm)	398	398	398	398	1.8
	1.9	Wheelbase	y (mm)	1495	1495	1495	1495	1.9
	Weights	2.1	Service weight	kg	2870	2840	3280	3250
2.2		Axle loading, laden front/rear	kg	3940/530	3930/520	4600/680	4580/670	2.2
2.3		Axle loading, unladen front/rear	kg	1340/1530	1330/1510	1360/1920	1350/1900	2.3
Wheels, Chassis	3.1	Tyres	SE (L)	SE (L)	SE (L)	SE (L)	3.1	
	3.2	Tyre size, front	6.50-10 (14 PR)	6.50-10 (14 PR)	6.50-10 (14 PR)	6.50-10 (14 PR)	3.2	
	3.3	Tyre size, rear	18x7-8 (14 PR)	18x7-8 (14 PR)	18x7-8 (14 PR)	18x7-8 (14 PR)	3.3	
	3.5	Wheels, number front/rear (x = driven wheels)	2x/2	2x/2	2x/2	2x/2	3.5	
	3.6	Track width, front	b ₁₀ (mm)	900	900	900	900	3.6
	3.7	Track width, rear	b ₁₁ (mm)	870	870	870	870	3.7
	Basic Dimensions	4.1	Mast/fork carriage tilt forward/backward	α/β (°)	7/7	7/7	7/7	7/7
4.2		Lowered mast height	h ₁ (mm)	2185	2185	2185	2185	4.2
4.3		Free lift	h ₂ (mm)	150	150	150	150	4.3
4.4		Lift height	h ₃ (mm)	3300	3300	3300	3300	4.4
4.5		Extended mast height	h ₄ (mm)	3920	3920	3920	3920	4.5
4.7		Overhead load guard (cab) height	h ₆ (mm)	2145	2145	2145	2145	4.7
4.8		Seat height/standing height	h ₇ (mm)	1049	1049	1049	1049	4.8
4.12		Coupling height	h ₁₀ (mm)	380	380	380	380	4.12
4.19		Overall length	l ₁ (mm)	3386	3386	3406	3406	4.19
4.20		Length to face of forks	l ₂ (mm)	2236	2236	2256	2256	4.20
4.21		Overall width	b ₁ /b ₂ (mm)	1080/-	1080/-	1080/-	1080/-	4.21
4.22		Fork dimensions	s/e/l (mm)	40x100x1150	40x100x1150	40x100x1150	40x100x1150	4.22
4.23		Fork carriage ISO 2328, class/type A, B		2 A	2 A	2 A	2 A	4.23
4.24		Fork carriage width	b ₃ (mm)	980	980	980	980	4.24
4.31		Ground clearance, laden, under mast	m ₁ (mm)	120	120	120	120	4.31
4.32		Ground clearance, centre of wheelbase	m ₂ (mm)	130	130	130	130	4.32
4.33	Aisle width for pallets 1000x1200 crossways	Ast (mm)	3618	3618	3640	3640	4.33	
4.34	Aisle width for pallets 800x1200 lengthways	Ast (mm)	3818	3818	3840	3840	4.34	
4.35	Turning radius	Wa (mm)	2020	2020	2042	2042	4.35	
4.36	Smallest pivot point distance	b ₁₃ (mm)	560	560	560	560	4.36	
Performance Data	5.1	Travel speed, laden/unladen	km/h	18.3/19.1	18.7/19.5	18.0/18.8	18.5/19.3	5.1
	5.2	Lift speed, laden/unladen	m/s	0.61/0.62	0.61/0.63	0.60/0.62	0.60/0.63	5.2
	5.3	Lowering speed, laden/unladen	m/s	0.55/0.49	0.55/0.49	0.57/0.49	0.57/0.49	5.3
	5.5	Drawbar pull, laden/unladen	N	10810	12765	10550	12650	5.5
	5.7	Gradient performance, laden/unladen	%	23	25	20	22	5.7
	5.9	Acceleration time, laden/unladen	s	5.2/4.6	5.1/4.7	5.4/4.8	5.2/4.5	5.9
	5.10	Service brake		mech./hydr.	mech./hydr.	mech./hydr.	mech./hydr.	5.10
V-Motor	7.1	Engine manufacturer/type		Mitsubishi S4Q2	Nissan K21	Mitsubishi S4Q2	Nissan K21	7.1
	7.2	Engine power acc. to ISO 1585	kW	28	29	28	29	7.2
	7.3	Rated speed	min ⁻¹	2200	2150	2200	2150	7.3
	7.4	No. of cylinders/cubic capacity	/cm ³	4/2505	4/2065	4/2505	4/2065	7.4
	7.5	Fuel consumption acc. to VDI cycle ¹⁾	l/h, kg/h	2.5	2.2	2.85	2.4	7.5
Other Details	8.1	Type of drive control		hydrodynamic	hydrodynamic	hydrodynamic	hydrodynamic	8.1
	8.2	Operating pressure for attachments	bar	160	160	160	160	8.2
	8.3	Oil volume for attachments	l/min	45	45	45	45	8.3
	8.4	Sound level at driver's ear according to EN 12053 ²⁾	dB(A)	79	79	79	79	8.4
	8.5	Tow coupling, type DIN		15170/type H	15170/type H	15170/type H	15170/type H	8.5

1) 60 VDI working cycles/h
2) tolerance 2 dB(A)

Make use of the advantages

Ergonomic operator's cab

The comfortable operator's cab helps maximise the operator's work capacity and offers outstanding ergonomics:

- Large visible step provides easy and safe mounting and dismounting from the cab.
- Anti-vibration mounted drive unit reduces vibration and noise.
- Operator's seat has 3 means of adjustment.
- Infinitely adjustable steering column.
- Large, comfortable footwell with automotive style pedal layout.
- Spacious, roomy cab.
- Hydraulic levers and directional control are ergonomically positioned to the right of the operator.
- Excellent forward panoramic visibility through mast and carriage.
- Clear visible analogue instrument panel, which has extensive warning and control lights.
- Comfortable working environment in all weathers through cabs (optional) in various designs.

Strong motors

Large capacity industrial engines, specially designed for the requirements of forklift trucks provide power in every situation:

- 2.5 litre diesel engine (Mitsubishi), delivers 28 kW of power with a maximum torque of 132 Nm at 1600 rpm.
- 2.1 litre LPG engine (Nissan), delivers 29 kW of power with a maximum torque of 140 Nm at 1600 rpm.
- Long service life due to robust construction and low engine speed
- 500 hour servicing interval.
- Low soot emission (Diesel engine). Various types of soot filter systems (optional).
- 48l Diesel tank integrated in chassis.
- Low level standard exhaust (upward direction optional).
- Easy access for maintenance and service through one-piece motor cover with wide opening angle to the rear and removable floor plate.

Highly loadable hydrodynamic transmission

The hydrodynamic drive unit has an automatic power shift transmission enabling:

- Optimised power transfer, with maximum effectiveness for medium and high speeds.
- Sensitive and shock-free power transfer.
- Combined inching speed/brake pedal allows sensitive driving while under full lifting performance. A conventional brake pedal which also allows exact positioning on ramps and gradients.

Protected electric installation

- 12 Volt battery with 72 Ah.
- 50A 3-phase AC alternator.
- LPG motor with maintenance-free, non-contacting transistor ignition.
- The complete electrics are protected against water and dust according to IP 54 and accessibly mounted on the overhead load guard console.

Tyres for every application

- Superelastic tyres as standard.
- Pneumatic tyres, wide tyres and non-marking SE tyres are available as an option.

Front axle					
Tyre type	No.	Size	PR	Track width	Truck width
SE tyres	2	6.50-10	—	900	1080
Pneumatic tyres	2	6.50-10	14	900	1080
SE wide track	2	23x9-10	—	938/1045	1160
Rear axle					
Tyre type	No.	Size	PR	Track width	Truck width
SE tyres	2	18x7-8	—	870	1080
Pneumatic tyres	2	18x7-8	14	870	1080
SE wide track	2	200/50-10	—	870	1080

Precise steering

Hydraulic steering for effortless, precise steering without steering return kickback.

- Hydraulic steering provides low effort shock free steering, for maximum operator comfort and safety. 4.25 turns on steering wheel lock to lock.
- Steering axle mounted high in the chassis with integrated steering cylinder for maximum stability.

Safe braking

Two independent braking systems act on the front wheels.

- Foot brake: hydraulically operated drum brake with warning light for low brake fluid indication.
- Parking brake: hand-operated dual servo cable-pull brake with operation warning light.

Reliable hydraulics

The highly efficient filter system ensures clean oil and thus prolongs the lifespan of all components:

- Suction filter and return line filter.
- 40 l hydraulic tank integrated in chassis.
- The hydraulic tank is vented through a breather.
- Pressure limiting valves prevent excessive pressure and overloads.

Masts with 6-bearing fork carriage

All components of the mast are designed for excellent visibility, high stability and a long service life:

- Slim-line mast sections with lift cylinders hidden behind, give an excellent field of view for safe operation.
- 6-bearing fork carriage as standard.
- Visibility through the carriage is excellent.
- Smooth transitions provided by the mast damping system, particularly on full free lift masts.

Additional equipment

Various special equipment and attachments to adjust to different application or customer requirements are optionally available.

Jungheinrich UK Ltd.

Head Office:

Sherbourne House · Sherbourne Drive
Tilbrook · Milton Keynes MK7 8HX
Phone 01908 363100
Fax 01908 363180

info@jungheinrich.co.uk
www.jungheinrich.co.uk



JUNGHEINRICH
Machines. Ideas. Solutions.