

DIMENSIONS AND PERFORMANCES ARE INDICATIVE AND VARIATIONS ARE POSSIBLE WITHOUT ANY INFORMATION.  
 All property rights reserved by C.E.L.A. S.r.l. - The drawing shall not be reproduced or in any way utilized, for the manufacture of the component or unit herein illustrated and must not be released to other parties, without written consent. any infringement will be legally pursued.

DIMENSIONI E CARATTERISTICHE SONO INDICATIVE E SUSCETTIBILI DI VARIAZIONI SENZA PREAVVISO.  
 Proprietà della C.E.L.A. S.r.l. - Senza autorizzazione scritta della stessa il presente disegno non potrà essere comunque utilizzato né venire comunicato a terzi o riprodotto. La società proprietaria tutela i propri diritti a norma di legge.

PROVISIONAL

	DENOMINAZIONE - NAME		DISEGNATO - DRAWN	CONTROLLATO - CHECKED
	OVERALL DIMENSIONS		R.F.	T.S.
	VEICOLO - CHASSIS		AREA DI LAVORO - WORKING AREA	
	IVECO DAILY 35S11		-	
PIATTAFORMA - PLATFORM MODEL		P.T.T. - G.V.W.	DISEGNO N° - DRAWING N°	
DT-22		3.5 T	1005591	

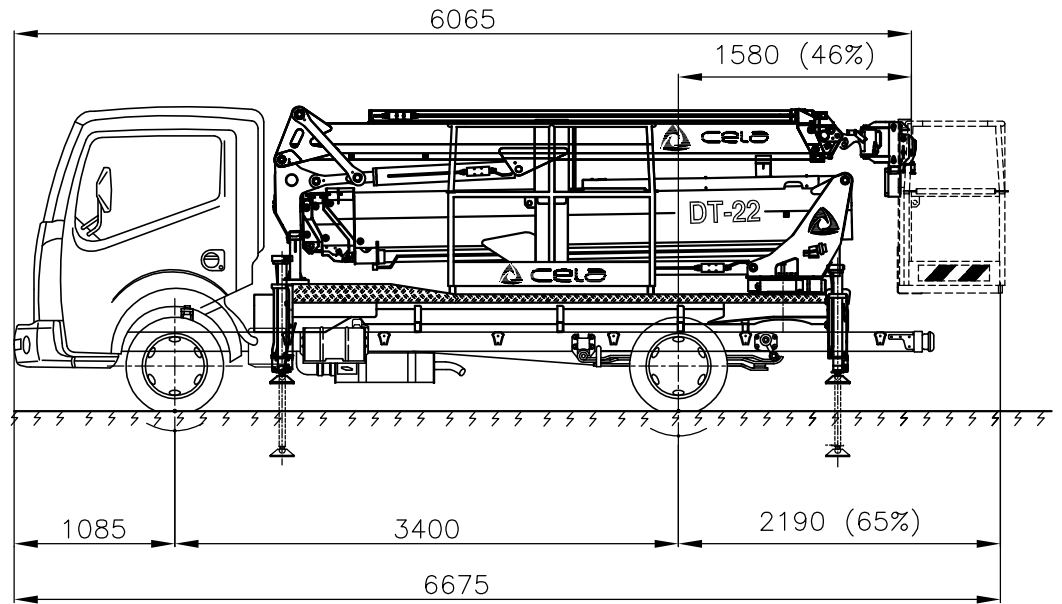
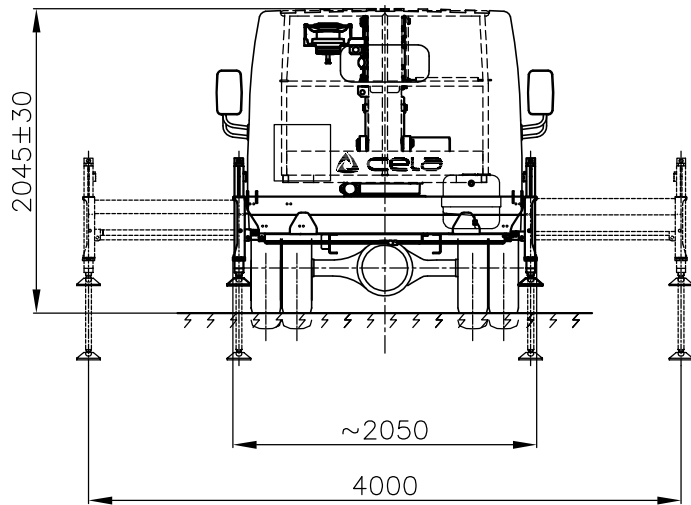

DIMENSIONS AND PERFORMANCES ARE INDICATIVE AND VARIATIONS ARE POSSIBLE WITHOUT ANY INFORMATION.  
 All property rights reserved by C.E.L.A. S.r.l. - The drawing shall not be reproduced or in any way utilized, for the manufacture of the component or unit herein illustrated and must not be released to other parties, without written consent. any infringement will be legally pursued.

DIMENSIONI E CARATTERISTICHE SONO INDICATIVE E SUSCETTIBILI DI VARIAZIONI SENZA PREAVVISO.  
 Proprietà della C.E.L.A. S.r.l. - Senza autorizzazione scritta della stessa il presente disegno non potrà essere comunque utilizzato né venire comunicato a terzi o riprodotto. La società proprietaria tutela i propri diritti a norma di legge.

PROVISIONAL

	DENOMINAZIONE - NAME		DISEGNATO - DRAWN	CONTROLLATO - CHECKED
	OVERALL DIMENSIONS		R.F.	T.S.
VEICOLO - CHASSIS		AREA DI LAVORO - WORKING AREA		
NISSAN NT400 35.12		-		
PIATTAFORMA - PLATFORM MODEL	P.T.T. - G.V.W.	DISEGNO N° - DRAWING N°		
DT-22	3.5 T	1005643		

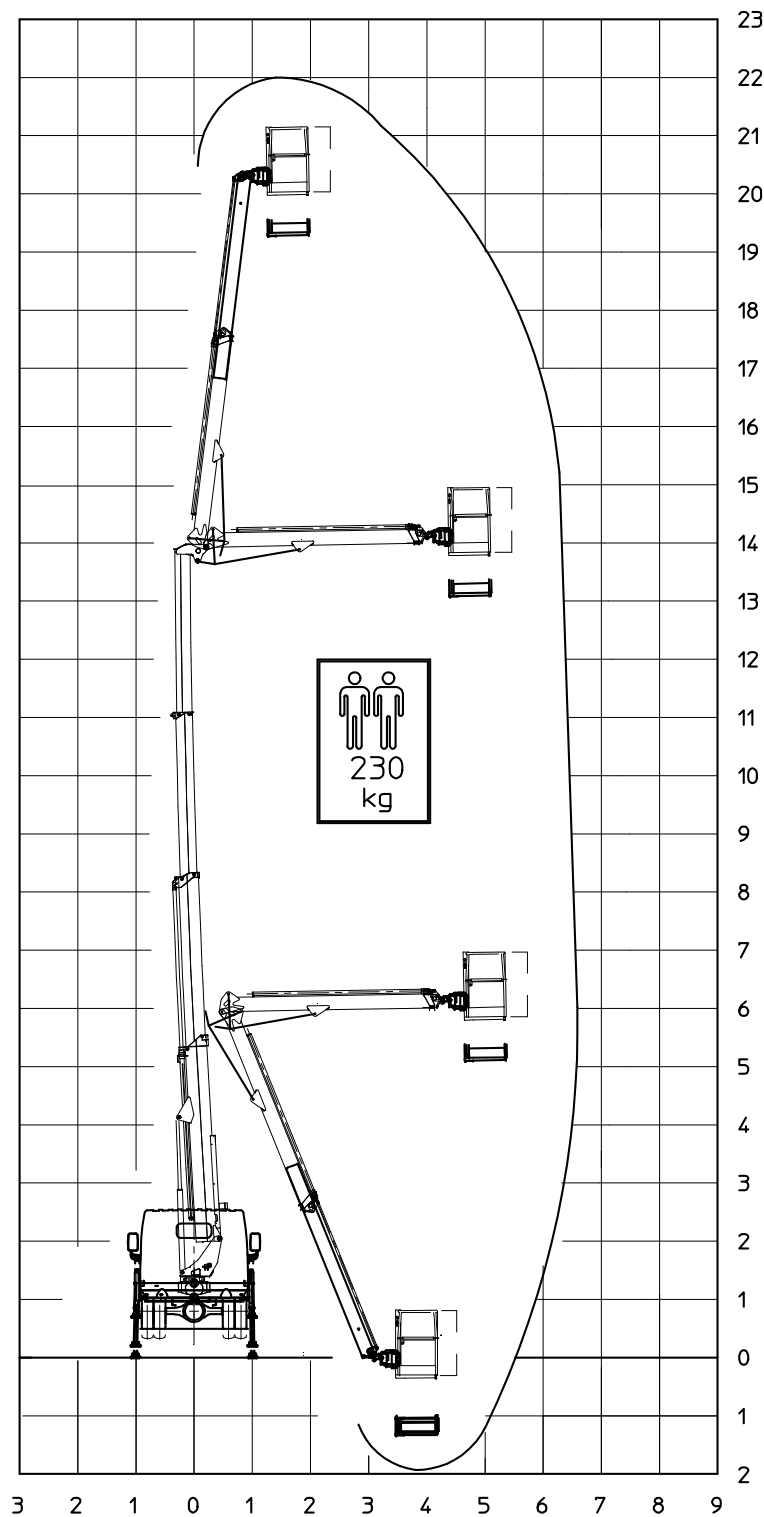

TRAVERSE IN SAGOMA - OUTRIGGER IN

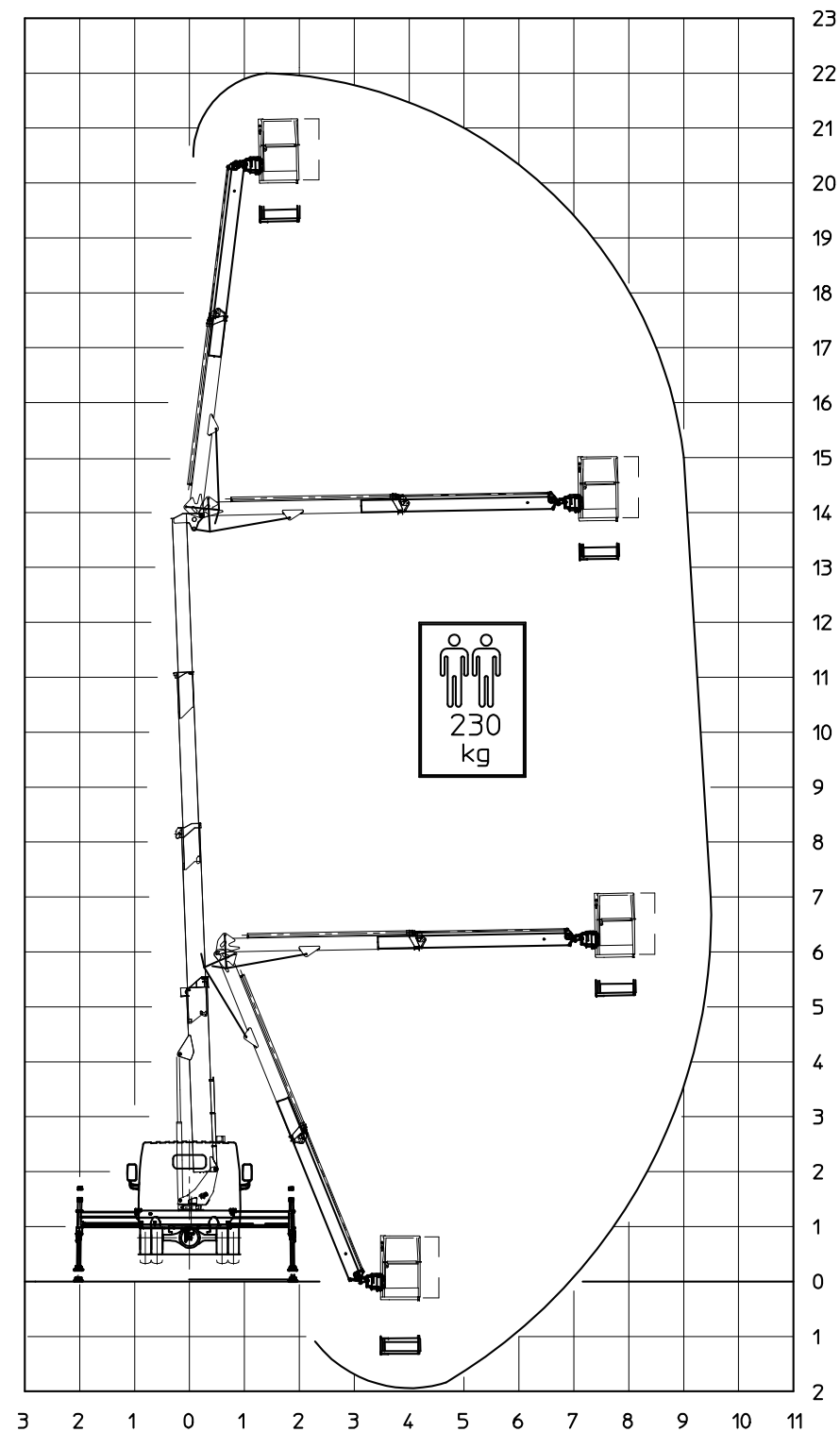

TRAVERSE ESTESE - OUTRIGGER OUT

Proprietà della CELA S.r.l. - senza autorizzazione scritta della stessa il presente disegno non potrà essere comunque utilizzato né venire comunicato a terzi o riprodotto. La società proprietaria tutela i propri diritti a norma di legge.

All property rights reserved by CELA S.r.l. - The drawing shall not be reproduced or in any way utilized, for the manufacture of the components or unit herein illustrated and must not be released to other parties, without consent, any infringement will be legally pursued.

CELA S.r.l. - Via dei Ponticelli tr. 1a 2/4 - 25040 Corte Franca (BS) - Italy

PROVISIONAL



DENOMINAZIONE - NAME <b>AREA DI LAVORO</b>		DISEGNATO - DRAWN <b>T.S.</b>	CONTROLLATO - CHECKED <b>Z.P.</b>
VEICOLO - CHASSIS -		INGOMBRI - DIMENSIONS -	
PIATTAFORMA - PLATFORM MODEL <b>DT 22</b>	P.T.T. - G.V.W. <b>3,5 T</b>	DISEGNO N° - DRAWING N° <b>1005715</b>	