

DVH 600

The DVH 600 was developed particularly for use in footpaths/cycleways, verges and parking lots.

DVH rollers have set standards not only with regard to design, but also in performance, longevity, operational safety and environmental protection.



Avantages

- ▶ Front-mounted engine for easy maintenance.
- ▶ Large-volume water tank.
- ▶ Guide bar with stepless speed adjustment and dead man's control.
- ▶ Vibration can be switched on and off via hand lever at any engine speed.
- ▶ Less vibration transmission to the handle thanks to isolated engine assembly.
- ▶ Fast gear facilitates movements on construction site.
- ▶ Central lifting device for easy and safe transport.
- ▶ Mechanical parking brake to prevent unintended movements.

Technical features

Type	DVH 600	
Service weight as per CECE	kg (lbs)	420 (925)
Drum width	mm (in.)	650 (25.6)
Drum diameter	mm (in.)	325 (13)
Centrifugal force	kN (lbs)	10 (2250)
Frequency	Hz (r.p.m.)	60 (3600)
Engine manufacturer	Lombardini / 15 LD 315	
Engine type	Diesel	
Engine output, max.	kW (HP)	5.0 (6.8)
Engine power output at operating speed	kW (HP) at r.p.m.	4.0 (5.5) at 3000
Working speed	m/min (ft/min)	0-58 (0-197)
Water tank capacity	L (gal)	33 (8.75)

We reserve the right to amend the specifications without prior notice.

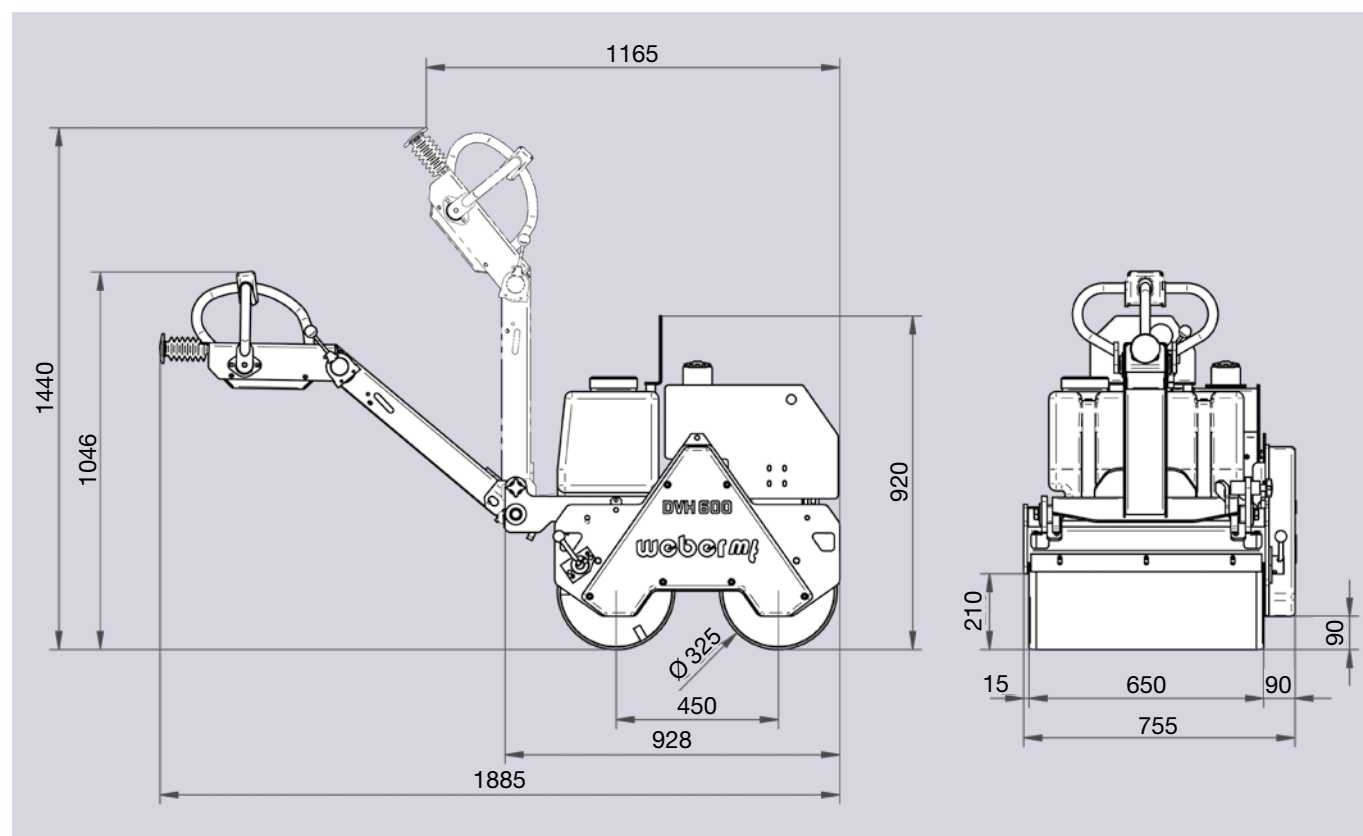

Dimensions in mm.

Weber Maschinentechnik GmbH

Im Boden 5-8 · 57334 Bad Laasphe · Germany · P. O. Box 101465 · 57326 Bad Laasphe · Germany
Phone +49 (0) 27 54 / 3 98-0 · Fax +49 (0) 27 54 / 3 98-101 · info@webermt.de · www.webermt.de