

* | 270 kW (362 HP)

▲ | 41600 - 43300 kg

📦 | 1.44 - 2.31 m³

* | 290 kW (389 HP)

▲ | 49000 - 50800 kg

📦 | 1.71 - 3.60 m³

* | 290 kW (389 HP)

▲ | 52000 - 53800 kg

📦 | 1.71 - 3.60 m³



DX420LC-3 / DX490LC-3 / DX530LC-3

Crawler Excavator



Doosan – Building your tomorrow today

■ Be part of the great Doosan family

The Doosan Group was founded in 1896. It is headquartered in Seoul, South Korea, and today is one of the fastest growing companies in the world:

From 1896, the first modern local store in Korea



117 years of history

20th century & beyond, major actor in various industries all around the world



43100 employees in 34 countries

Today, a global leader in the Infrastructure Support Business (ISB)



Global presence:

- 56 subsidiaries
- 3700 distributors worldwide

AN EXPLOSIVE GROWTH RECORD
DOOSAN GROUP REVENUE

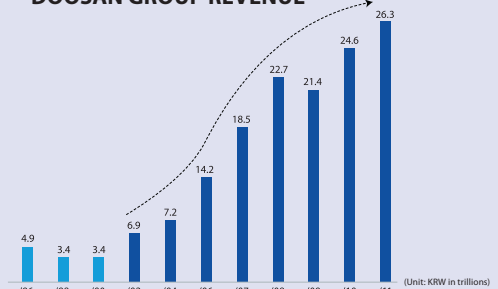

Dramatic growth over the past decade:

- 23% average annual revenue growth since 2000
- From 3.4 to 24.6 KRW trillion between 1998 and 2010



■ Doosan Group



Doosan Engine

- World N° 2 leader in medium speed marine diesel engines



Doosan Mecatec

- World N° 1 chemical process equipment company
- 60000 tonnes annual production capacity



Doosan Construction & Engineering

A pioneering leader in construction of residential and public buildings, civil works and industrial facilities.



Doosan Heavy Industries & Construction

- World N° 1 in desalination plant
- World N° 1 in heat recovery steam generator area
- World N° 1 in mould & tool steel
- World N° 3 in crankshafts

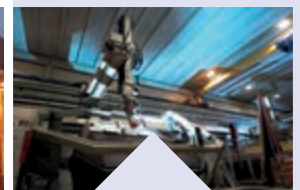

Doosan Infracore

- World N° 1 in compact loaders
- World N° 1 in attachments
- World N° 1 in portable air compressors
- N° 1 in China: 22000 excavators sold in 2010

Doosan – One-stop shop

■ From machine manufacturer... TO FULL SOLUTION PROVIDER

All Doosan Infracore Construction Equipment products are designed and built to deliver the highest levels of performance and productivity. Parts and service support are intended to fully maintain the performance, productivity and reliability expected of our products throughout their entire lifetime as well as ensure the highest trade-in and residual values.

■ Ask your dealer for a full range of services designed for you!

Your dealer is your local specialist to ensure you receive the maximum benefits from our integrated package. Think in advance, think to ensure the success of your equipment!

- ① Genuine parts
- ② Extension of warranty
- ③ Maintenance contract
- ④ Telematics
- ⑤ Monitoring systems
- ⑥ Financial solutions
- ⑦ Doosan approved attachments



Construction Equipment



Machine tools



Engines

Doosan Infracore Construction Equipment

We have been building a global production and business network since 1990 to become one of the world's foremost construction equipment manufacturers. In addition to operating large-scale factories worldwide, we have also established sales subsidiaries, branches and a dealership network all over the globe, making us a truly global player in every respect.



TAKE A TOUR

Reinforced castings and forged steel pivot points

Reinforced heavy-duty arm and boom to withstand high impact materials and ensure high durability

Available for special applications, Super Long Reach of 19.6 m and Semi SLR of 16.0 m

Massive maximum bucket and arm digging forces of 27.3 and 24.4 ton - DX420LC-3
30.8 and 30.0 ton - DX490LC-3 & DX530LC-3

All-round visibility with better view through the rear and right windows

Standard anti-slip steps and platforms for easy access to cab and maintenance compartments

Large, robust boom and arm cylinders for smooth, powerful operation

New work lights with improved illumination (standard: 2 front frame, 4 front & 2 rear cab-mounted, 2 boom mounted and 1 rear side)

COMFORTABLE WORKSPACE AND EXPERT CONTROL

- Spacious, newly designed, pressurised ROPS cab with low noise and vibration levels
- Fully adjustable heated air suspension seat as standard
- Air conditioning with climate control
- Joystick and switches integrated in the control stand for precise operation
- Jog shuttle switch to control various machine functions
- 4 working and 4 power modes for maximum efficiency
- Proportional control (flow/pressure) to operate attachments smoothly and precisely
- New, user-friendly 7" TFT LCD colour monitor
- Rear camera and large side mirrors
- Inside cab microphone, air compressor, straight travel pedal, two pump flow & oil washed air cleaner (optional)

RAISE PROFITS WITH MORE PRODUCTIVITY & FUEL EFFICIENCY

MAXIMUM EFFICIENCY

- New powerful ISUZU "Common Rail", Stage IIIB compliant, EGR, Diesel Particulate Filter, 6 cylinder engines
- e-EPOS System (Electronic Power Optimising System) and hydraulic power boost function for optimised combustion and minimised emissions
- Efficient conversion of engine output into hydraulic performance for better fuel efficiency and lower costs
- Automatic overheating prevention, low oil pressure sensor, engine emergency cut-off switch, auxiliary mode switch and automatic 2-speed adjustment, etc

EASY MAINTENANCE

- Easy access to all maintenance components
- Radiator and oil cooler are separate for better cooling and easy maintenance
- Maintenance data available directly from control panel
- 2 fuel pre-filters with water separator
- PC access for maintenance and repairs
- Self-diagnosis function
- Reliable Doosan parts
- Turbo centrifugal air pre-cleaning system

SOLID STRENGTH

- Heavy-duty X-shaped undercarriage with integrated track spring and idler plus durable box section track frame
- Extreme durability: forged steel and deep-hardened top rollers – Oil-lubricated bottom rollers – Heat treated sprocket – Deep-hardened, heat treated, grease lubricated & sealed-for-life track chains
- Increased speed and tractive force on any terrain

6 different widths to match all your applications
DX420LC-3: fixed undercarriage
• narrow or standard: 3.00 or 3.35 m
DX490LC-3 & DX530LC-3: variable undercarriage
• narrow, retracted / extended: 2.99 / 3.49 m
• wide, width retracted / extended: 3.34 / 3.90 m

DX420LC-3

DX490LC-3

DX530LC-3

Top performance and fuel efficiency

■ Expect the best performance from your machine

The DX420LC-3, DX490LC-3 & DX530LC-3 take even the heaviest tasks in their stride with efficient, dependable performance that saves you time and money:

- Improved hydraulic system using the engine power more effectively, maximising pump output and offering more comfort, smoothness and accuracy
- Increased digging power, lifting capacities and traction force combine for performance you can rely on day after day
- Improved fuel efficiency means you can keep costs down and reduce the environmental impact



6 ASSETS TO YOUR BENEFIT!

- Power: 270 kW (362 HP) at 2000 rpm and 290 kW (389 HP) at 1800 rpm
- New 6 cylinder engines: 13% higher m³ extracted / fuel consumption ratio
- Productivity: side lifting capacity at 6 m reach and 3 m height: DX420LC-3: 11.5 t – DX490LC-3: 17.2 t – DX530LC-3: 18.9 t
- Excavation: max. bucket digging force: DX420LC-3: 27.3 t – DX490LC-3 & DX530LC-3: 30.8 t
- Traction: max. drawbar pull: DX420LC-3: 34.8 t – DX490LC-3 & DX530LC-3: 38.8 t
- Max. digging depth: DX420LC-3: 8.43 m (3.95 m arm) – DX490LC-3: 8.40 m (3.98 m arm) – DX530LC-3: 15.12 m (SLR arm)



EFFICIENT MANAGEMENT OF FUEL AND HYDRAULICS

“Common Rail” Isuzu engine

The heart of the DX420LC-3, DX490LC-3 & DX530LC-3 is a powerful “Common Rail” Isuzu 6 cylinder engine, carefully designed with common rail injection and 4 valves per cylinder. Powerful torque allows efficient use of the hydraulic system and faster working cycles.

Already known for its outstanding reliability, the Isuzu engine has been optimised for the DX420LC-3, DX490LC-3 & DX530LC-3 and is now compliant with the Stage IIIB European regulations using EGR (Exhaust Gas Recirculation) and DPF (Diesel Particulate Filter). In combination with the e-EPOS electronic control system, it offers the ultimate in power delivery and fuel economy.

Variable geometry turbocharger

Ensures optimal air flow to the engine combustion chamber under all speed and load conditions. NOx levels can be controlled more efficiently and fuel economy is improved while machine power, response and performance are maintained.



ADVANCED TECHNOLOGY FOR OPTIMUM POWER MANAGEMENT

e-EPOS system (Electronic Power Optimising System)

If the engine is the heart of the excavator, the e-EPOS is its brain. It provides a perfectly synchronised communication link between the engine’s ECU (Electronic Control Unit) and the hydraulic system. A CAN (Controller Area Network) system enables a constant flow of information between the engine and hydraulic system, ensuring power is delivered exactly as needed.

Simple and efficient

- Choice between 4 power modes and 4 working modes guarantees optimum performance in all conditions
- Proportional auxiliary control for attachments (flow/pressure)
- Electronic control of fuel consumption optimises efficiency
- Auto-idle function enables fuel saving
- Regulation and precise control of the flow rate required by the work group

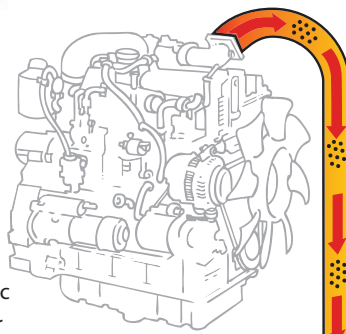

EGR with diesel particulate filter

EGR, which requires enhanced cooling capacity, reduces NOx by recirculating exhaust back into the engine. This dilutes the amount of oxygen in the combustion chamber and lowers the combustion peak temperature.

Exhaust

Exhaust with higher PM concentration goes in.

DOC (Diesel Oxidation Catalyst) reacts with exhaust and transforms PM emissions into harmless substances.

Diesel particulate filter filters exhaust to remove PM.

Cleaned exhaust with lower PM (Particulate Matter) concentration comes out.

- Self-diagnosis function allows technical problems to be resolved quickly and efficiently
- Operational memory provides a graphic display of the machine status
- Maintenance and oil change intervals can be displayed
- More smoothness and controllability for better operator comfort and improved overall productivity

Quick and efficient

The main hydraulic pumps have an increased capacity, reducing cycle times for heightened productivity. A high capacity gear pump improves pilot line efficiency.

Smooth and fast

The swing drive minimises shocks during rotation while making increased torque available to ensure rapid cycles.

Separate radiator and oil cooler

The radiator and oil cooler have been separated. This reduces noise as well as improving cooling efficiency and decreasing fuel consumption and power demand.



The ideal workspace – designed around you

The DX420LC-3, DX490LC-3 & DX530LC-3 are designed to provide you with the best possible working conditions. The sophisticated pressurised ROPS cab is ISO-certified for your safety. Its spacious interior offers a fully adjustable, heated air suspension seat. Comfortably seated, you have easy access to several storage compartments and a clear all-round view of the worksite. Noise and vibration levels have been reduced while air conditioning and automatic climate control allow you to keep working for hours on end without feeling tired.



Heated air suspension seat (standard)

As well as being adjustable and offering lumbar support, the seat has an air suspension system to reduce vibrations. It also features a button to activate the seat heating system. A storage box has been placed under the seat for extra convenience.



Storage space

Plenty of storage space means you can keep all your personal belongings within reach. The new cab contains 7 storage compartments including one hot/cool box (linked to the HVAC system).

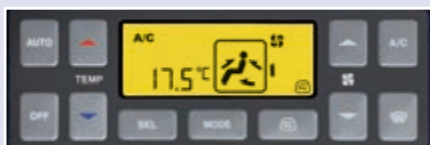

Air conditioning with climate control

The electronically controlled air conditioning system features 5 different operating modes allowing the operator to adjust the airflow to suit conditions. A recirculated air function is also available.



MP3/USB radio and USB port

A USB port (standard) allows connection of an MP3 player (MP3/USB radio with CD player optional).



ERGONOMIC OPERATOR ENVIRONMENT

Feel the comfort of a seat that fits you perfectly:

Using a dual positioning cursor, you can slide the seat back from the joysticks for the best working position. You can also slide the entire seat assembly to adjust the reach to the control pedals to your leg length.

- 1 Large sun roof
- 2 Sun visor
- 3 Straight ergonomic pedals
- 4 Flat, spacious, easy-to-clean floor
- 5 Upper front window is strut-assisted for easy, reliable adjustment and integrates a sun shade
- 6 Joysticks and switches are integrated in adjustable control consoles
- 7 Separate seat height adjustment lever and cushion tilting function
- 8 Storage compartment for sunglasses
- 9 Hot/cool box
- 10 Photo sensor detects radiant energy of the sun and adjusts temperature automatically

CabSus mount

The cab features a new suspension system (CabSus mount) that combines high vibration dampening with outstanding protection against impact. The system absorbs shocks and vibrations much more effectively than a conventional viscous suspension system.



Maximum controllability for enhanced productivity

Doosan's unique new jog shuttle switch gives you easy, precise control over all machine functions. Using highly sensitive joysticks and clear controls positioned for convenient access, you are able to work safely and confidently with minimum effort. Proportional auxiliary flow means that the excavator's huge power is matched by smooth, confident manoeuvres, whether you are digging or loading a dump truck. Swing torque has been increased while the speed of light-load operations such as grading has also been improved due to the larger hydraulic flow volume. The highest standards of efficiency are just a finger's reach away.



Jog shuttle control switch

- Power mode and Work mode
- Auto-idle / Buzzer Stop
- Adjustments of rpm, hydraulic flow and pressure for attachments
- Rear view camera
- Multimedia: - video: AVI (DivX®), MP4, WMV
- audio: MP3
- Menu change or selection

Colour LCD monitor panel

The upgraded 7" TFT LCD panel features a day and night display and has been relocated within the operator's line of sight. The monitor is user-friendly and gives full access to machine settings and maintenance data. Any abnormality is clearly displayed on the screen, allowing you to work safely and confidently with an accurate overview of all conditions. All functions are totally controllable, directly via the screen or using the Jog shuttle switch.



4 Work modes to suit your application

- 1-way mode and 2-way mode
- Digging mode and lifting mode

4 Power modes for maximum efficiency

- Power plus mode
- Power mode
- Standard mode
- Economy mode

Gauges

- Engine coolant and hydraulic oil temperatures
- Fuel level
- Eco symbol: changes colour when operating conditions change (idle, normal or loading)
- Eco gauge: shows the average fuel efficiency for 1 minute of operation
- Warning symbols



4 Work modes



4 Power modes



Auto-idle

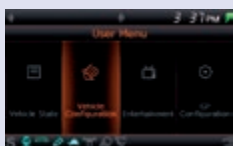

User menu

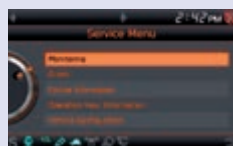

Service menu



Attachment presets



Filter/oil information



Anti-theft protection

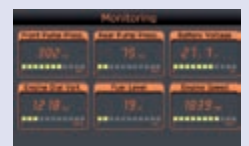

Monitoring

Your safety – our biggest concern

- A rear view camera shows you a clear view of what's happening behind the machine. A side view camera is also available as an option for jobs requiring extra safety measures
- Cab and boom lights are fitted as standard, greatly enhancing safety on night-time jobs
- Large side mirrors improve all-round visibility (ISO compliant)

Other standard safety features include: automatic overheating prevention, low oil pressure sensor, engine emergency cut-off switch, auxiliary mode switch (to stop the pump if the control system malfunctions), overload warning device. An optional travel/swing alarm is also available.



Excellent digging power performance provides quick cycle times and efficient extraction of hard or compacted material.



Simple operation

- "Short stroke" joysticks enable easy, precise control of all operations
- A thumb wheel switch and buttons on the joysticks allow proportional control of attachments such as grabs, crushers and grapples
- A straight travel pedal can be installed to facilitate operation when moving in a straight line, to avoid having to use the conventional 2 pedals
- The switches have been ergonomically placed on the right and positioned according to the frequency with which they are used



Dynamic power management

- Automatic travel speed function
- Activation of the power boost control system increases digging power by 10%
- A one-touch deceleration button immediately reduces engine speed to low or idle
- Auto-idling starts after 4 seconds at low rpm. This decreases fuel consumption and reduces noise levels in the cab
- Jog shuttle dial for engine rpm

Floating boom function (optional)

- The intelligent floating boom mode allows the boom to move up and down freely when external force is applied.
- The breaker mode restricts the boom to downward movement only. This means that the breaker can be operated using only the weight of the work group on the front, without additional force. The breaker remains in constant contact with the object. The result is reduced shock and vibration and longer breaker service life.
- During truck loading, the lowering of the boom can be controlled without hydraulic pump flow discharge. This increases productivity and fuel efficiency.

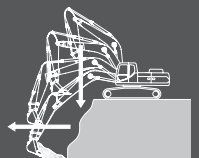
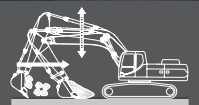

Uncompromised quality and total customer support

■ Designed for long-term all-round heavy duty

In your profession you need equipment you can depend on. At DOOSAN we use highly specialised design and analysis tools to make sure our machines are as robust and durable as can be. Our materials and structures undergo stringent testing for strength and resilience in the most extreme conditions.

RESILIENT CHAIN FOR TOP CLASS RELIABILITY

The DX420LC-3, DX490LC-3 & DX530LC-3 are fitted with the same super-strong chain. The 21.6 cm link pitch, 4.7 cm pin diameter and heavy-duty running gear are ideally suited for long, trouble-free service in the roughest conditions.

- Track chains: the sealed and lubricated track chains are specifically designed for better pin and bushing retention. Exclusive heat treatment gives the links a consistent surface and strong core hardness, enhancing their durability
- Track guards: three guards per track frame (two guards for DX420LC-3) protect against track derailment.



For extra protection, full length track guards can also be fitted



Variable chassis		DX490LC-3 – DX530LC-3		Retracted / extended
Narrow		2.99 / 3.49 m		
Wide		3.34 / 3.90 m		
Fixed chassis		DX420LC-3		
Narrow		3.00 m		
Standard		3.35 m		



Strengthened boom

Finite Element Analysis (FEA) has been used to calculate the best load distribution throughout the boom structure. Combined with increased material thickness, this means that element fatigue is limited and both reliability and component life are increased.

Arm assembly

Cast elements and reinforcements have been added to give the arm assembly greater strength and a longer lifetime. The arm centre and end boss have been strengthened and reinforced bars added to better protect the base of the arm.

Hydraulically driven reversing oil cooler fan

The ECU sets the revolution speed of the cooling fan according to the coolant, hydraulic oil, and ambient temperature; effectively uses the engine output to reduce wasteful fuel consumption and lowers noise during low-speed fan revolution.



Extra-strong X-chassis

The X-shaped undercarriage has been designed using Finite Element Analysis and 3D computer simulation to ensure optimum structural integrity and durability. The swing gear is solid and stable.

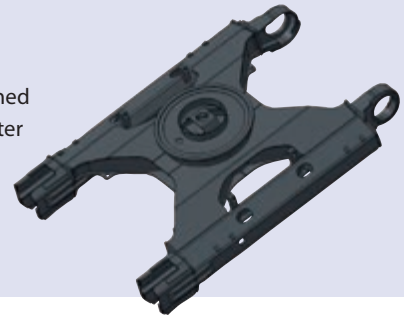

Heavy-duty sprocket

The sprocket is deep induction hardened and the depth pattern on the entire tooth profile is optimised for long-lasting service. Cast steel sprockets guarantee the highest resistance and durability even in the most severe applications. The sprocket tooth shape has been redesigned to prevent popping and increase component life.



Integrated track spring and idler

The track spring and idler have been joined together for long-lasting performance and convenient maintenance. A new seal and cylinder body rod have been used to avoid leakage. Special heat treatment ensures optimum hardness and long-lasting resistance to wear.

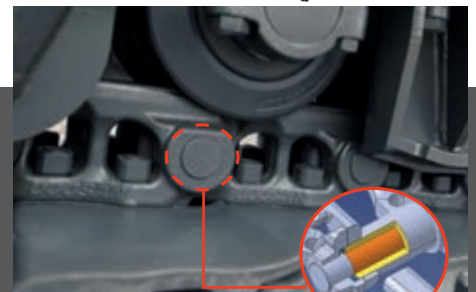

Tracks

For long-term dependability in all conditions, the chain is composed of sealed, self-lubricating links which are isolated from all external contamination. The tracks are locked by mechanically bolted pins. In areas subjected to great stress, the track link thickness has been reinforced.



The heavy-duty undercarriage provides excellent stability and durability. It is designed to excel in tough working environments.



Extra strong sintered bushings

A highly lubricated metal is used for the boom pivot to increase the component lifetime and extend the greasing intervals. The bucket pivot features EM (Enhanced Macrosurface) bushings. These feature a tailored surface pattern and self-lubricating coating for optimised greasing and more efficient evacuation of debris.

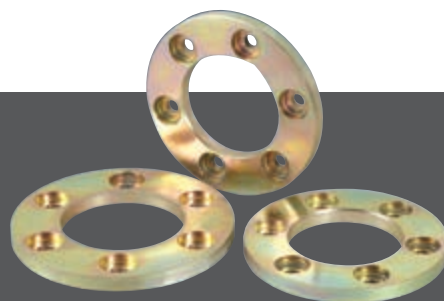

Ultra hard wear-resistant discs

New materials have been used to enhance resistance to wear and to extend service intervals. Wear plates on the inside and the outside of the bucket lugs greatly increase disc lifetime.



Polymer shim

A polymer shim is added to the bucket pivot to maintain precise control over the equipment and extend greasing intervals.

More value – less maintenance

Short maintenance operations at long intervals mean you can depend on your equipment being available on site when it's needed. Our machines are designed for simple routine maintenance, while skilled Doosan technicians are available to provide extra support when you need it. You can choose the package you need from a broad range of service agreements to get the most out of your machine. Uptime, productivity and residual value are all maximised, making these excavators an economical and rewarding choice.



Maintenance access made simple

- Large handrails are installed along with anti-slip steps and plates, for safer, easier access to the engine compartment
- The cab's air conditioning filter is lockable and placed on the side of the cab for easy access
- A battery cut-off switch makes it easy to disconnect the battery during long-term storage
- The hour meter display can be easily checked from ground level
- Cock valves have been fitted on the pre-filter piping line and fuel tank drain piping to make servicing easier and prevent pollution from leakage



Access to components

- Engine parts can be easily reached via the top and side panels
- As the radiator and oil cooler have been separated, access for cleaning is made easier



- For extra accessibility and servicing convenience, all filters (engine oil filter, fuel pre-filter, fuel filter and pilot filter) are located in the pump compartment



Efficient air filtering

The large capacity forced air cleaner removes over 99 % of airborne particles, while the pre-cleaning system uses centrifugal force to eliminate dust. An oil-washed air cleaner is also available as an option.

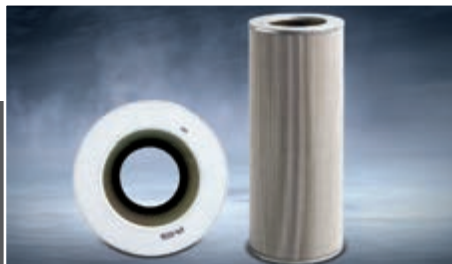

Protective oil return filter

The protection of the hydraulic system is made more effective by the use of glass fibre technology in the main oil return filter. With more than 99.5% of foreign particles filtered out, the oil change interval is extended.



Engine oil filters

The engine oil filters offers a high level of filtration allowing a long interval between changes. It is easy to access and is positioned to avoid contaminating the surrounding environment.



Fuel pre-filters with water separator sensor

High efficiency fuel filtration is attained by the use of multiple filters. These include 2 fuel pre-filters fitted with a water separator that removes moisture, dirt and debris from the fuel. A warning sensor is added to each fuel filter to indicate when water draining is required.

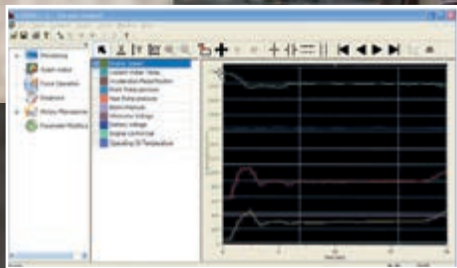

PC monitoring

A PC monitoring function enables connection to the e-EPOS system. Thus, various parameters can be checked during maintenance, including pump pressures and engine speed. This information can be saved and printed for analysis



Convenient fuse box

The fuse box is located in the storage compartment behind the seat, providing a clean environment and convenient access.



Regeneration switch

Diesel particulate filter regeneration is automatic and doesn't interfere with operation. When the level of soot is too high, a warning symbol alerts the operator that he can activate regeneration at any time.



Centralised greasing points

To make maintenance easier, the greasing points have been centralised.

Technical specifications

* Engine

• Model	DX420LC-3 / DX490LC-3 & DX530LC-3 ISUZU AL-6UZ1X / ISUZU AL-6WG1X 4-Cycle Water-Cooled, Variable Geometry Turbocharged, Common Rail Direct Injection, Exhaust Gas Recirculation (EGR)
• No. of cylinders	6
• Rated power	DX420LC-3 / DX490LC-3 & DX530LC-3 367 PS (270 kW) at 2000 rpm / 394 PS (290 kW) at 1800 rpm (ISO 9249) 270 kW (362 HP) at 2000 rpm / 290 kW (389 HP) at 1800 rpm (SAE J1995) 258 kW (345 HP) at 2000 rpm / 276 kW (370 HP) at 1800 rpm (SAE J1349)
• Max. torque	DX420LC-3 / DX490LC-3 & DX530LC-3 146 kgf/m (1430 Nm) at 1500 rpm / 198 kgf/m (1940 Nm) at 1350 rpm
• Idle (low - high)	DX420LC-3 / DX490LC-3 & DX530LC-3 900 [+/-25] - 2000 [+/-30] rpm / 950 [+/-25] - 1950 [+/-30] rpm
• Piston displacement	DX420LC-3 / DX490LC-3 & DX530LC-3 9389 cm ³ / 15681 cm ³
• Bore x stroke	DX420LC-3 / DX490LC-3 & DX530LC-3 120 mm x 145 mm / 147 mm x 154 mm
• Starter	DX420LC-3 / DX490LC-3 & DX530LC-3 24 V x 5.5 kW / 24 V x 7.0 kW
• Batteries – Alternator	2 x 12 V, 150 Ah – 24 V, 80 Ah
• Air filter	Double element and pre-filtered dust separator with automatic dust evacuation.

* Weight

	Shoe width (mm)	Operating weight (t)			Ground pressure (kgf/cm ²)		
		DX420LC-3	DX490LC-3	DX530LC-3	DX420LC-3	DX490LC-3	DX530LC-3
Triple grouser	600 (Std)	41.9	49.0	52.0	0.76	0.85	0.90
	750	42.6	50.0	53.0	0.62	0.69	0.73
	800	42.9	50.3	53.3	0.58	0.65	0.69
	850	43.3	50.8	53.8	0.53	0.58	0.62
Double grouser	600	42.0	49.1	52.1	0.76	0.85	0.90

DX420LC-3: with standard track
DX490LC-3 / DX530LC-3: with wide variable track

* Undercarriage

Very robust construction throughout. All welded structures designed to limit stresses. High-quality, durable materials. Lateral chassis welded and rigidly attached to undercarriage. Track rollers lubricated for life. Idlers and sprockets fitted with floating seals. Track shoes made of induction-hardened alloy with triple grouser. Heat-treated connecting pins. Hydraulic track adjuster with shock-absorbing tension mechanism.

• Number of rollers and track shoes per side	DX420LC-3 / DX490LC-3 & DX530LC-3
Upper rollers (standard shoe):	2 / 1
Lower rollers:	9 / 11
Number of links & shoes per side:	50 / 53
Overall track length:	5200 mm / 5455 mm

* Hydraulic system

The brain of the excavator is the e-EPOS (Electronic Power Optimizing System). It allows the efficiency of the hydraulic system to be optimised for all working conditions and minimises fuel consumption. The e-EPOS is connected to the engine's electronic control unit (ECU) via a data transfer link to harmonise the operation of the engine and hydraulics.

- The hydraulic system enables independent or combined operations
- Two travel speeds offer either increased torque or high speed
- Cross-sensing pump system for fuel savings
- Auto deceleration system
- Four operating modes, four power modes
- Button control of flow and pressure in auxiliary hydraulic circuits
- Computer-aided pump flow control

• Maximum system pressure

Implement (boom/arm/bucket):	
Work, travel:	330 kg/cm ² [+10/0]
Rotation:	DX420LC-3: 280 kg/cm ² DX490LC-3 & DX530LC-3: 300 kg/cm ²
Power:	350 kg/cm ² [+10/0]

* Pumps

Pump	Type	Displacement (cm ³ /rev)		Max. flow @ 1800 rpm (l/min)		Relief valve pressure (kgf/cm ²)
		DX420LC-3	DX490LC-3 DX530LC-3	DX420LC-3	DX490LC-3 DX530LC-3	
Main (2)	Tandem, Axial piston	185.0	200.0	2 X 333	2 X 360	-
Pilot	Gear	10.8	10.8	24.1	24.1	40.8

* Hydraulic cylinders

Piston rods and cylinder bodies of high-strength steel. Shock-absorbing mechanism fitted in all cylinders for shock-free operation and extended piston life.

Cylinders	Quantity	Bore x rod diameter x stroke (mm)	
		DX420LC-3	DX490LC-3 & DX530LC-3
Boom	2	170 x 115 x 1485	170 x 115 x 1650
Arm	1	180 x 120 x 1820	190 x 130 x 1980
Bucket	1	160 x 110 x 1320	170 x 115 x 1341
Semi SLR Bucket	1	-	140 x 90 x 1150
SLR Bucket	1	-	120 x 80 x 1060

* Swing mechanism

- High-torque, axial piston motor with 2-stage planetary reduction gear bathed in oil
 - Swing circle: single-row, shear type ball bearing with induction-hardened internal gear
 - Internal gear and pinion immersed in lubricant
- **Max. swing speed** DX420LC-3 / DX490LC-3 & DX530LC-3
0 to 8.8 rpm / 0 to 8.5 rpm
- **Max. swing torque** DX420LC-3 / DX490LC-3 & DX530LC-3
(Eff.=79%) 16360 (13740) kgf/m / 20130 (15880) kgf/m

* Drive

Each track is driven by an independent, high-torque axial piston motor through a planetary reduction gearbox. Two levers / foot pedals guarantee smooth travel with counter-rotation on demand.

- **Travel speed (low - high)** DX420LC-3 / DX490LC-3 & DX530LC-3
3.3 - 5.5 km/h / 3.1 - 5.4 km/h
- **Maximum traction** DX420LC-3 / DX490LC-3 & DX530LC-3
(Eff.=75 - 85%) 18.6 - 34.8 t / 19.5 - 38.8 t
- **Maximum gradeability**
35° / 70%

* Buckets

Bucket Type	Capacity (m ³)	Width (mm)		Weight (kg)	DX420LC-3 Standard 3.35 m / narrow track 3.00 m				Bucket Type	Capacity (m ³)	Width (mm)		Weight (kg)	DX490LC-3 Wide 3.90 m / narrow 3.49 m		DX530LC-3 Wide 3.90 m / narrow 3.49 m					
		SAE	With side cutters		W/O side cutters	Boom: 6.70 m - CW: 8.2 t					SAE	With side cutters		W/O side cutters	Boom: 7.10 m - CW: 8.5 t *		Boom: 6.30 m - CW: 11.1 t		Boom: 9.00 m	Boom: 11.00 m	
						Arm: 2.60 m	Arm: 2.95 m	Arm: 3.25 m							Arm: 3.95 m	Arm: 2.90 m	Arm: 3.35 m	Arm: 2.40 m	Arm: 2.90 m	Arm: 6.00 m	Arm: 8.00 m
									SLR	0.93	1236	1173	705	-	-	-	-	-	A		
									Semi SLR	1.27	1445	1376	1091	-	-	-	-	A	-		
									Semi DC**	1.12	-	1500	1002	-	-	-	-	A	-		
										1.37	-	1800	1117	-	-	-	-	A	-		
GP	1.44	1273	1192	1415	A / A	A / A	A / A	A / A	GP	1.80	1474	1381	1718	A / A	A / A	A / A	A / A	-	-		
	1.68	1429	1348	1516	A / A	A / A	A / A	A / C		2.14	1682	1588	1910	A / A	A / A	A / A	A / A	-	-		
	1.90	1547	1466	1636	A / A	A / B	A / B	B / C		2.39	1837	1744	2027	A / B	A / B	A / A	A / A	-	-		
	2.16	1745	1664	1755	A / C	B / C	B / C	C / D		2.86	2130	2037	2279	B / C	C / D	A / A	A / A	-	-		
HD	1.55	1298	1224	1653	A / A	A / A	A / A	A / B	HD	1.73	1301	1224	1831	A / A	A / A	A / A	A / A	-	-		
	1.80	1452	1374	1762	A / A	A / B	A / B	B / C		2.01	1451	1374	1948	A / A	A / A	A / A	A / A	-	-		
	2.05	1602	1524	1910	A / B	B / C	B / C	C / D		2.29	1601	1524	2106	A / A	A / B	A / A	A / A	-	-		
	2.31	1758	1680	2020	B / C	C / D	C / D	D / -		2.85	1901	1824	2381	B / C	C / D	A / A	A / A	-	-		
	-	-	-	-	-	-	-	-		3.20	2101	2024	2601	C / D	C / D	A / A	A / A	-	-		
	-	-	-	-	-	-	-	-		3.60	2306	2229	2740	D / -	D / -	A / B	A / B	-	-		
Rock	1.51	-	1497	1623	A / A	A / A	A / A	A / B	Rock	1.71	-	1572	1971	A / A	A / A	A / A	A / A	-	-		

A: Suitable for materials with a density less than or equal to 2100 kg/m³

B: Suitable for materials with a density less than or equal to 1800 kg/m³

(*) Counterweight for DX490LC-3 narrow is 9.2 t (***) Ditch Cleaning

C: Suitable for materials with a density less than or equal to 1500 kg/m³

D: Suitable for materials with a density less than or equal to 1200 kg/m³

Based on ISO 10567 and SAE J296, arm length without quick-coupler. Shoe: 600 mm. For reference only.

* Digging forces (ISO)

DX420LC-3		Boom: 6700 mm Arm: 3250 mm Bucket: 1.90 m ³	Boom: 6700 mm Arm: 2600 mm Bucket: 2.16 m ³	Boom: 6700 mm Arm: 2950 mm Bucket: 1.90 m ³	Boom: 6700 mm Arm: 3950 mm Bucket: 1.44 m ³	Boom: 6700 mm HD Arm: 3250 mm Rock Bucket: 1.51 m ³
BUCKET (Normal/Press. Up)	t	25.6 / 27.1	25.6 / 27.1	25.6 / 27.1	25.6 / 27.1	25.6 / 27.1
	kN	251.0 / 265.7	251.0 / 265.7	251.0 / 265.7	251.0 / 265.7	251.0 / 265.7
ARM (Normal/Press. Up)	t	18.6 / 19.7	23.0 / 24.4	20.7 / 21.9	16.0 / 16.9	18.6 / 19.7
	kN	182.4 / 193.2	225.5 / 239.3	203.0 / 214.7	156.9 / 165.7	182.4 / 193.2
DX490LC-3		Boom: 7100 mm Arm: 3350 mm Bucket: 2.14 m ³		Boom: 7100 mm Arm: 2900 mm Bucket: 2.39 m ³		HD Boom: 7100 mm HD Arm: 3350 mm Rock Bucket: 1.71 m ³
BUCKET (Normal/Press. Up)	t	29.0 / 30.8		29.0 / 30.8		29.0 / 30.8
	kN	284.4 / 302.0		284.4 / 302.0		284.4 / 302.0
ARM (Normal/Press. Up)	t	21.4 / 22.7		24.4 / 25.8		21.4 / 22.7
	kN	209.8 / 222.6		239.3 / 253.0		209.8 / 222.6
DX530LC-3		Boom: 6300 mm Arm: 2900 mm Bucket: 3.20 m ³	Boom: 6300 mm Arm: 2400 mm Bucket: 3.60 m ³	Boom: 9000 mm Arm: 6000 mm Semi SLR Bucket: 1.27 m ³		Boom: 11000 mm Arm: 8000 mm SLR Bucket: 0.93 m ³
BUCKET (Normal/Press. Up)	t	29.0 / 30.8	29.0 / 30.8	29.0 / 30.8		29.0 / 30.8
	kN	284.4 / 302.0	284.4 / 302.0	284.4 / 302.0		284.4 / 302.0
ARM (Normal/Press. Up)	t	24.4 / 25.8	28.3 / 30.0	13.8 / 15.1		10.9 / 11.9
	kN	239.3 / 253.0	277.5 / 294.2	135.3 / 148.1		106.9 / 116.7

* Fluid capacities

- **Fuel tank** DX420LC-3 / DX490LC-3 & DX530LC-3
640 l / 685 l
- **Cooling system (radiator)** DX420LC-3 / DX490LC-3 & DX530LC-3
70 l / 90 l
- **Hydraulic oil tank**
390 l
- **Engine oil** DX420LC-3 / DX490LC-3 & DX530LC-3
41 l / 57 l
- **Swing drive** DX420LC-3 / DX490LC-3 & DX530LC-3
7.9 l / 2 x 5 l
- **Travel device** DX420LC-3 / DX490LC-3 & DX530LC-3
2 x 6.3 l / 2 x 10 l

* Environment

Noise levels comply with environmental regulations (dynamic values).

- **Noise level LwA** DX420LC-3 / DX490LC-3 & DX530LC-3
Guaranteed - measured: 104 dB(A) - 103 dB(A) (2000/14/EC) / 107 dB(A) - 106 dB(A) (2000/14/EC)
- **Operator LpA**
72 dB(A) (ISO 6396)

Dimensions

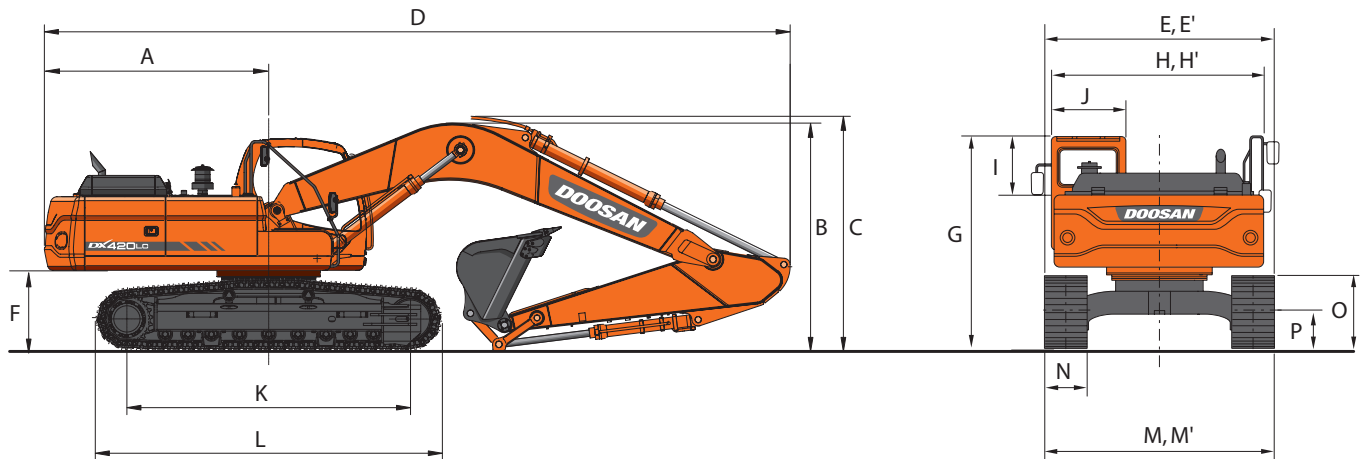

* Dimensions

	DX420LC-3 (fixed track)					DX490LC-3 & DX530LC-3 (variable track)							
	6700					6700 HD	7100		7100HD	6300		9000	11000
Boom length - mm													
Arm length - mm	3250	2600	2950	3950	3250 HD	3350	2900	3350HD	2400	2900	6000	8000	
Bucket capacity - m ³	1.90	2.16	1.90	1.44	1.51 Rock	2.14	2.39	1.71 Rock	3.60	3.20	1.27	0.93	
A Tail swing radius - mm	3760	3760	3760	3760	3760	3800	3800	3800	3800	3800	3800	3800	
B Shipping height (boom) - mm	3350	3585	3570	3390	3350	3580	3800	3580	4010	4125	3765	3935	
C Shipping height (hose) - mm	3455	3680	3660	3495	3455	3705	3895	3705	4060	4165	3910	4070	
D Shipping length - mm	11750	11860	11835	11760	11750	12230	12330	12230	11720	11530	14155	16195	
E Shipping width std. (wide*) - mm	3350	3350	3350	3350	3350	3340	3340	3340	3340	3340	3340	3340	
E' Shipping width narrow - mm	3000	3000	3000	3000	3000	2990	2990	2990	2990	2990	2990	2990	
F Counterweight clearance - mm	1265	1265	1265	1265	1265	1460	1460	1460	1460	1460	1460	1460	
G Height over cab - mm	3154	3154	3154	3154	3154	3350	3350	3350	3350	3350	3350	3350	
H House width - mm	2990	2990	2990	2990	2990	2990	2990	2990	2990	2990	2990	2990	
H' House width (cat walk) - mm	-	-	-	-	-	3296	3296	3296	3296	3296	3296	3296	
I Cab height above house - mm	845	845	845	845	845	845	845	845	845	845	845	845	
J Cab width - mm	1010	1010	1010	1010	1010	1010	1010	1010	1010	1010	1010	1010	
K Tumbler distance - mm	4250	4250	4250	4250	4250	4470	4470	4470	4470	4470	4470	4470	
L Track length - mm	5200	5200	5200	5200	5200	5455	5455	5455	5455	5455	5455	5455	
M Undercarriage width std (wide*) - mm	3350	3350	3350	3350	3350	3340 / 3900**	3340 / 3900**	3340 / 3900**	3340 / 3900**	3340 / 3900**	3340 / 3900**	3340 / 3900**	
M' Undercarriage width narrow - mm	3000	3000	3000	3000	3000	2990 / 3490**	2990 / 3490**	2990 / 3490**	2990 / 3490**	2990 / 3490**	2990 / 3490**	2990 / 3490**	
N Shoe width std. - mm	600	600	600	600	600	600	600	600	600	600	600	600	
O Track height - mm	1050	1050	1050	1050	1050	1210	1210	1210	1210	1210	1210	1210	
P Ground clearance - mm	540	540	540	540	540	770	770	770	770	770	770	770	

(*) : DX490LC-3 & DX530LC-3 "E" and "M" refer to wide variable track

(**) : retracted / extended

* Component weights

Item	unit	DX420LC-3	DX490LC-3	DX530LC-3	Remarks
Upper structure without front	kg	9715	10600		without counterweight
Counterweight	kg	8200	8500 / 9200	11100	
Lower structure assembly	kg	15050*	19330**		(*) Standard track 600 mm shoe (**) Wide variable track 600 mm shoe
Front assembly	kg	8820	10474	10525	Based on standard †
Boom	mm	6700 / 6700 HD	6300 / 7100 / HD 7100 / 9000* / 11000*		including bushing
	kg	2920 / 3126	3512 / 3756 / 3747 / 4017 / 4499		(*) only DX490LC-3 & DX530LC-3
Arm	mm	2600 / 2950 / 3250 / HD 3250 / 3950	2400 / 2900 / 3350 / HD3350 / 6000* / 8000*		including bushing
	kg	1333 / 1570 / 1460 / 1541 / 1720	1510 / 1570 / 1731 / 1756 / 2049 / 2457		(*) only DX490LC-3 & DX530LC-3
Bucket	kg	(1.90 m ³) 1627	(2.14 m ³) 1910		
Boom cylinder (each)	kg	383	424		
Arm cylinder	kg	520	625 (7.10 m boom) / 570 (6.30 m boom)		
Bucket cylinder	kg	340	6.00 m arm*: 240 / 8.00 m arm*: 145 / all other: 371		(*) only DX530LC-3

(†) DX420LC-3: standard front – 6.70 m boom, 3.25 m arm, 1.90 m³ GP bucket.

DX490LC-3: standard front – 7.10 m boom, 3.35 m arm, 2.14 m³ GP bucket.

DX530LC-3: standard front – 6.30 m boom, 2.90 m arm, 3.20 m³ HD bucket.

Working range

DX420LC-3
DX490LC-3
DX530LC-3

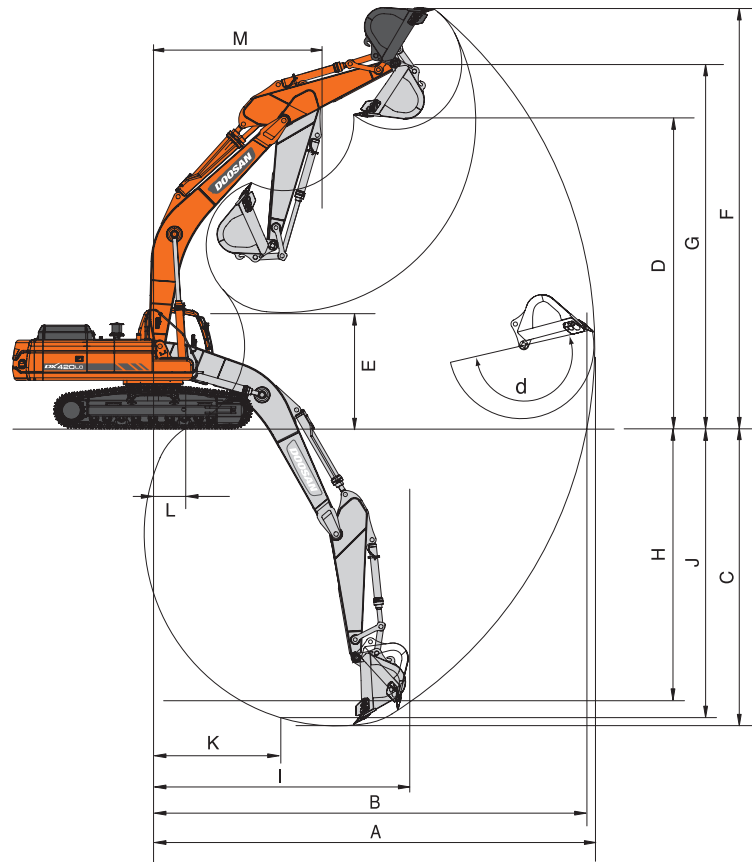

* Working range

		DX420LC-3					DX490LC-3 & DX530LC-3 (variable track)						
		6700				6700 HD	7100		7100HD	6300		9000	11000
Boom length - mm		3250	2600	2950	3950	3250 HD	3350	2900	3350HD	2400	2900	6000	8000
Arm length - mm		1.90	2.16	1.90	1.44	1.51 Rock	2.14	2.39	1.71 Rock	3.60	3.20	1.27	0.93
Bucket capacity - m ³													
A	Max. digging reach - mm	11495	10880	11200	12180	11495	12125	11720	12125	10340	10765	16060	19615
B	Max. digging reach (ground) - mm	11290	10660	10980	11980	11290	11865	11455	11865	10035	10475	15870	19455
C	Max. digging depth - mm	7740	7080	7435	8435	7740	7790	7340	7790	6270	6765	11795	15125
D	Max. loading height - mm	7710	7385	7535	8100	7710	7865	7725	7865	6585	6685	9800	11890
E	Min. loading height - mm	2995	3660	3300	2300	2995	3130	3580	3130	3460	2930	2076	1465
F	Max. digging height - mm	10820	10820	10625	11240	10820	11050	10920	11050	9575	9705	12755	14435
G	Max. bucket pin height - mm	9440	9115	9260	9830	9440	9690	9550	9690	8410	8510	11415	13355
H	Max. vertical wall depth - mm	4320	3630	3980	5110	4320	4370	4045	4370	2270	2885	10300	12805
I	Max. radius vertical - mm	9440	9170	9315	9700	9440	9970	9710	9970	9170	9315	9515	12165
J	Max. digging depth (8' level) - mm	7555	6870	7240	8290	7555	7635	7165	7635	6040	6555	11670	15010
K	Min. radius 8' line - mm	3420	3395	3400	3475	3420	3895	3885	3895	3215	3195	4885	6165
L	Min. digging reach - mm	785	2365	1760	-225	785	840	2010	840	1985	1110	-109	40
M	Min. swing radius - mm	4475	4495	4505	4555	4475	5210	5235	5210	4785	4755	6525	7825
d	Bucket angle - °	183	183.7	183	183.9	183	189.1	181.2	189.1	183.1	181.1	175.2	177.6



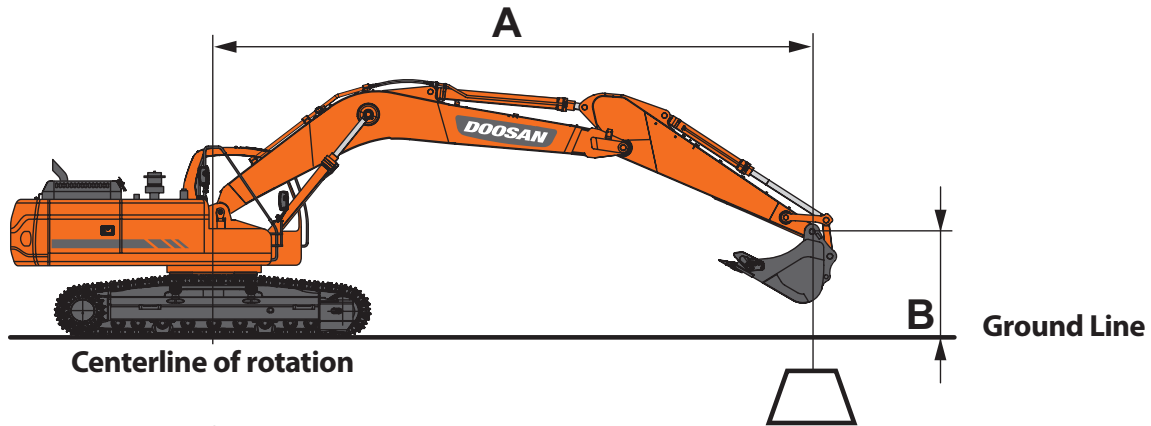

DX420LC-3 – Standard configuration

Standard track width: 3350 mm • Boom: 6700 mm • Arm: 3250 mm • W/O Bucket • Shoe: 600 mm • Counterweight: 8200 kg

Units: 1000 kg

A (m) \ B (m)	1.5		3.0		4.5		6.0		7.5		9.0		Max. lift		A (m)
7.5									9.77 *	9.15			9.42 *	9.42 *	6.92
6.0									10.13 *	8.98			8.77 *	7.87	8.15
4.5					16.30 *	16.30 *	12.77 *	12.20	11.00 *	8.65	9.96	6.45	8.66 *	5.90	9.48
3.0					20.57 *	17.38	14.81 *	11.45	12.07 *	8.26	9.75	6.26	8.61	5.52	9.73
1.5					18.92 *	16.28	16.48 *	10.83	12.57	7.91	9.54	6.08	8.47	5.40	9.74
0 (Ground)					20.72 *	15.88	17.33	10.45	12.29	7.66	9.40	5.94	8.68	5.50	9.52
-1.5			14.63 *	14.63 *	23.10 *	15.84	17.16	10.30	12.17	7.55	9.37	5.92	9.32	5.89	9.03
-3.0	18.00 *	18.00 *	23.11 *	23.11 *	21.27 *	16.01	16.29 *	10.36	12.22	7.61			10.70	6.74	8.24
-4.5			23.61 *	23.61 *	17.98 *	16.41	13.79 *	10.64					10.97 *	8.55	7.06
-6.0													10.59 *	10.59 *	4.93

Option 1

Standard track width: 3350 mm • Boom: 6700 mm • Arm: 2600 mm • W/O Bucket • Shoe: 600 mm • Counterweight: 8200 kg

Units: 1000 kg

A (m) \ B (m)	3.0		4.5		6.0		7.5		9.0		Max. lift		A (m)	
9.0					11.57 *	11.57 *						11.56 *	11.56 *	6.01
7.5												10.97 *	9.13	7.41
6.0					12.16 *	12.16 *	11.04 *	8.85				10.82 *	7.46	8.30
4.5			18.37 *	18.37 *	13.88 *	11.98	11.79 *	8.56				10.16	6.58	8.85
3.0					15.76 *	11.28	12.72 *	8.21	9.73	6.26		9.54	6.14	9.11
1.5					17.12 *	10.75	12.55	7.91	9.58	6.12		9.38	6.00	9.13
0 (Ground)			18.16 *	15.97	17.35	10.48	12.34	7.72				9.67	6.15	8.88
-1.5			22.27 *	16.06	17.14 *	10.43	12.30	7.68				10.55	6.68	8.36
-3.0	24.99 *	24.99 *	19.93 *	16.32	15.57 *	10.58	11.82 *	7.85				11.79 *	7.84	7.51
-4.5	19.61 *	19.61 *	15.83 *	15.83 *	11.91 *	11.01						11.36 *	10.61	6.17

Option narrow

Narrow track width: 3000 mm • Boom: 6700 mm • Arm: 3250 mm • W/O Bucket • Shoe: 600 mm • Counterweight: 8200 kg

Units: 1000 kg

A (m) \ B (m)	1.5		3.0		4.5		6.0		7.5		9.0		Max. lift		A (m)
9.0													9.42 *	9.17	6.92
7.5									9.77 *	8.04			8.77 *	6.90	8.15
6.0									10.13 *	7.88			8.57 *	5.76	8.97
4.5					16.30 *	16.30 *	12.77 *	10.63	11.00 *	7.56	9.91	5.62	8.66 *	5.12	9.48
3.0					20.57 *	14.79	14.81 *	9.90	12.07 *	7.18	9.71	5.43	8.57	4.78	9.73
1.5					18.92 *	13.74	16.48 *	9.30	12.51	6.83	9.50	5.25	8.43	4.66	9.74
0 (Ground)					20.72 *	13.37	17.25	8.93	12.23	6.59	9.35	5.12	8.64	4.74	9.52
-1.5			14.63 *	14.63 *	23.10 *	13.33	17.09	8.80	12.11	6.49	9.33	5.10	9.28	5.07	9.03
-3.0	18.00 *	18.00 *	23.11 *	23.11 *	21.27 *	13.49	16.29 *	8.85	12.17	6.54			10.65	5.81	8.24
-4.5			23.61 *	23.61 *	17.98 *	13.88	13.79 *	9.12					10.97 *	7.38	7.06
-6.0													10.59 *	10.59 *	4.93

DX490LC-3 – Standard configuration

Wide variable track width: 3900 mm • Boom: 7100 mm • Arm: 3350 mm • W/O Bucket • Shoe: 600 mm • Counterweight: 8500 kg

Units: 1000 kg

A (m) \ B (m)	3.0		4.5		6.0		7.5		9.0		Max. lift		A (m)
9.0							10.95 *	10.95 *			8.55 *	8.55 *	7.92
7.5							10.95 *	10.95 *			8.11 *	8.11 *	8.96
6.0							11.68 *	11.68 *	10.87 *	9.05	7.99 *	7.98	9.66
4.5			20.58 *	20.58 *	15.36 *	15.36 *	12.82 *	11.75	11.39 *	8.82	8.10 *	7.28	10.09
3.0			21.50 *	21.50 *	17.61 *	15.62	14.06 *	11.23	11.76	8.54	8.43 *	6.93	10.28
1.5			16.95 *	16.95 *	19.26 *	14.87	15.08 *	10.79	11.49	8.29	9.01 *	6.84	10.25
0 (Ground)			21.31 *	21.31 *	19.96 *	14.47	14.82	10.50	11.31	8.12	9.74	7.02	9.99
-1.5	17.16 *	17.16 *	25.91 *	22.78	19.69 *	14.35	14.69	10.38	11.26	8.08	10.48	7.54	9.49
-3.0	26.32 *	26.32 *	23.69 *	23.06	18.40 *	14.46	14.52 *	10.45			11.74 *	8.60	8.69
-4.5	25.50 *	25.50 *	19.97 *	19.97 *	15.65 *	14.80	11.58 *	10.81			11.53 *	10.80	7.51

Option 1

Wide variable track width: 3900 mm • Boom: 6300 mm • Arm: 2400 mm • W/O Bucket • Shoe: 600 mm • Counterweight: 9200 kg

Units: 1000 kg

A (m) \ B (m)	3.0		4.5		6.0		7.5		Max. lift		A (m)
7.5									14.02 *	14.02 *	6.84
6.0					15.14 *	15.14 *	13.86 *	12.64	13.79 *	11.98	7.74
4.5					17.00 *	17.00 *	14.53 *	12.34	13.85 *	10.57	8.28
3.0					19.02 *	16.61	15.47 *	11.96	13.51	9.92	8.51
1.5					20.39 *	16.03	16.08	11.65	13.42	9.82	8.47
0 (Ground)			27.61 *	24.72	20.69 *	15.75	15.90	11.48	14.10	10.26	8.15
-1.5			25.66 *	24.87	19.70 *	15.75	15.12 *	11.54	15.05 *	11.50	7.52
-3.0	27.55 *	27.55 *	21.91 *	21.91 *	16.74 *	16.06			14.99 *	14.43	6.48

Option narrow

Narrow variable track width: 3490 mm • Boom: 6300 mm • Arm: 2900 mm • W/O Bucket • Shoe: 600 mm • Counterweight: 9200 kg

Units: 1000 kg

A (m) \ B (m)	3.0		4.5		6.0		7.5		Max. lift		A (m)
7.5									12.57 *	11.43	7.36
6.0							13.01 *	10.96	12.40 *	9.43	8.20
4.5			20.70 *	20.70 *	16.12 *	14.97	13.88 *	10.64	12.72 *	8.39	8.71
3.0					18.32 *	14.18	14.98 *	10.25	12.43	7.88	8.93
1.5					20.01 *	13.56	15.91 *	9.90	12.33	7.77	8.89
0 (Ground)			28.09 *	20.21	20.70 *	13.21	15.70	9.68	12.86	8.06	8.59
-1.5	25.40 *	25.40 *	26.70 *	20.23	20.17 *	13.12	15.65	9.64	14.28	8.88	7.99
-3.0	31.25 *	31.25 *	23.61 *	20.54	18.01 *	13.29			14.65 *	10.72	7.03
-4.5			17.58 *	17.58 *					14.05 *	14.05 *	5.49

- Lifting capacities are in compliance with ISO 10567:2007(E).
- The load point is at the end of the arm.
- * = The nominal loads are based on hydraulic capacity.
- The nominal loads shown do not exceed 75% of tipping loads or 87% of hydraulic lifting capacity.
- For lifting capacity with bucket, simply subtract the actual weight of the bucket from the values.
- The configurations indicated do not necessarily reflect the standard equipment of the machine.

: Rating over front
 : Rating over side or 360°

DX530LC-3 – Standard configuration

Wide variable track width: 3900 mm • Boom: 6300 mm • Arm: 2900 mm • W/O Bucket • Shoe: 600 mm • Counterweight: 11100 kg

Units: 1000 kg

A (m) \ B (m)	3.0		4.5		6.0		7.5		Max. lift		A (m)	
7.5										12.57 *	12.57 *	7.36
6.0							13.01 *	13.01 *		12.40 *	12.13	8.20
4.5			20.70 *	20.70 *	16.12 *	16.12 *	13.88 *	13.71		12.72 *	10.86	8.71
3.0					18.32 *	18.32 *	14.98 *	13.31		13.20 *	10.26	8.93
1.5					20.01 *	17.86	15.91 *	12.95		13.56 *	10.16	8.89
0 (Ground)			28.09 *	27.40	20.70 *	17.50	16.29 *	12.72		13.98 *	10.56	8.59
-1.5	25.40 *	25.40 *	26.70 *	26.70 *	20.17 *	17.41	15.71 *	12.68		14.40 *	11.65	7.99
-3.0	31.25 *	31.25 *	23.61 *	23.61 *	18.01 *	17.59				14.65 *	14.08	7.03
-4.5			17.58 *	17.58 *						14.05 *	14.05 *	5.49

Option 1

Wide variable track width: 3900 mm • Boom: 7100 mm • Arm: 2900 mm • W/O Bucket • Shoe: 600 mm • Counterweight: 11100 kg

Units: 1000 kg

A (m) \ B (m)	3.0		4.5		6.0		7.5		9.0		Max. lift		A (m)
9.0											11.69 *	11.69 *	7.38
7.5							11.68 *	11.68 *			11.03 *	11.03 *	8.50
6.0					14.06 *	14.06 *	12.34 *	12.34 *	11.49 *	10.34	10.84 *	9.9	9.23
4.5					16.22 *	16.22 *	13.41 *	13.4	11.88 *	10.16	10.99 *	9.04	9.68
3.0					18.35 *	17.81	14.56 *	12.91	12.44 *	9.91	11.44 *	8.62	9.88
1.5					19.75 *	17.17	15.45 *	12.52	12.89 *	9.7	11.51	8.54	9.85
0 (Ground)			18.88 *	18.88 *	20.13 *	16.87	15.83 *	12.29	12.98 *	9.57	11.91	8.81	9.58
-1.5			25.21 *	25.21 *	19.56 *	16.83	15.49 *	12.23	12.31 *	9.59	12.19 *	9.52	9.05
-3.0	28.13 *	28.13 *	22.66 *	22.66 *	17.90 *	16.99	14.06 *	12.36			12.20 *	10.99	8.21
-4.5	22.44 *	22.44 *	18.40 *	18.40 *	14.48 *	14.48 *					11.67 *	11.67 *	6.95

Option narrow

Narrow variable track width: 3490 mm • Boom: 6300 mm • Arm: 2900 mm • W/O Bucket • Shoe: 600 mm • Counterweight: 11100 kg

Units: 1000 kg

A (m) \ B (m)	3.0		4.5		6.0		7.5		Max. lift		A (m)	
7.5										12.57 *	12.57 *	7.36
6.0							13.01 *	12.12		12.40 *	10.46	8.20
4.5			20.70 *	20.70 *	16.12 *	16.12 *	13.88 *	11.80		12.72 *	9.35	8.71
3.0					18.32 *	15.73	14.98 *	11.40		13.20 *	8.82	8.93
1.5					20.01 *	15.10	15.91 *	11.06		13.52	8.71	8.89
0 (Ground)			28.09 *	22.54	20.70 *	14.75	16.29 *	10.84		13.98 *	9.04	8.59
-1.5	25.40 *	25.40 *	26.70 *	22.57	20.17 *	14.67	15.71 *	10.80		14.40 *	9.95	7.99
-3.0	31.25 *	31.25 *	23.61 *	22.87	18.01 *	14.84				14.65 *	11.98	7.03
-4.5			17.58 *	17.58 *						14.05 *	14.05 *	5.49

Option Semi SLR

Wide variable track width: 3900 mm • Boom: 9000 mm • Arm: 6000 mm • W/O Bucket • Shoe: 900 mm • Counterweight: 11100 kg

Units: 1000 kg

A (m) \ B (m)	1.5		3.0		4.5		6.0		7.5		9.0		10.5		12.0		13.5		Max. lift		A (m)	
10.5																			4.94 *	4.94 *	11.98	
9.0															6.27 *	6.27 *			4.82 *	4.82 *	12.87	
7.5															6.41 *	6.41 *	4.89 *	4.89 *	4.79 *	4.79 *	13.53	
6.0													7.02 *	7.02 *	6.71 *	6.71 *	6.33 *	5.84	4.83 *	4.83 *	14.00	
4.5												8.40 *	8.40 *	7.63 *	7.63 *	7.10 *	6.97	6.77 *	5.73	4.94 *	4.94 *	14.30
3.0					18.11 *	18.11 *	14.10 *	14.10 *	11.12 *	11.12 *	9.40 *	9.40 *	8.29 *	8.26	7.55 *	6.75	7.04 *	5.59	5.13 *	5.00	14.44	
1.5					11.33 *	11.33 *	16.29 *	16.29 *	12.54 *	12.54 *	10.35 *	9.88	8.95 *	7.94	7.99 *	6.53	7.32 *	5.46	5.40 *	4.92	14.41	
0 (Ground)			6.22 *	6.22 *	11.43 *	11.43 *	17.78 *	16.52	13.65 *	12.14	11.15 *	9.48	9.51 *	7.67	8.38 *	6.35	7.30	5.34	5.77 *	4.94	14.23	
-1.5	7.52 *	7.52 *	8.98 *	8.98 *	13.30 *	13.30 *	18.56 *	16.08	14.38 *	11.77	11.72 *	9.19	9.94 *	7.46	8.50	6.21	7.21	5.26	6.30 *	5.07	13.88	
-3.0	10.19 *	10.19 *	11.86 *	11.86 *	16.07 *	16.07 *	18.74 *	15.90	14.69 *	11.57	12.02 *	9.02	10.11	7.33	8.42	6.13			7.04 *	5.32	13.35	
-4.5	12.99 *	12.99 *	15.06 *	15.06 *	19.63 *	19.63 *	18.38 *	15.91	14.59 *	11.52	11.99 *	8.97	10.07	7.30	8.42	6.13			7.89	5.75	12.63	
-6.0	16.11 *	16.11 *	18.77 *	18.77 *	22.70 *	22.70 *	17.47 *	16.07	14.02 *	11.60	11.55 *	9.03	9.63 *	7.36					8.28 *	6.47	11.66	
-7.5	19.76 *	19.76 *	23.36 *	23.36 *	20.28 *	20.28 *	15.86 *	15.86 *	12.82 *	11.83	10.48 *	9.22							8.54 *	7.70	10.38	
-9.0			22.12 *	22.12 *	16.63 *	16.63 *	13.19 *	13.19 *	10.56 *	10.56 *									8.66 *	8.66 *	8.66	

Standard and optional equipment

DX420LC-3
DX490LC-3
DX530LC-3

* Standard equipment

Engine
ISUZU Diesel engine combined with e-EPOS System, Common Rail direct injection, EU Stage IIIB compliant, EGR, diesel particulate filter DX420LC3: AL-6UJ21X / DX490LC-3 - DX530LC-3 : AL-6WG1X
Auto-idle function
Hydraulic system
Boom and arm flow regeneration Swing anti-rebound valves Spare ports (valve) One-touch power boost function Breaker piping Cylinder cushioning & contamination seals Control of auxiliary hydraulic flow and pressure from the display panel
Cab & Interior
Roll Over Protective Structure (ROPS) Pressurised, sound-insulated and CabSus mounted cab Heated, adjustable air suspension seat with adjustable headrest and armrest Air conditioning with climate control Pull-up type front window with sun roller blind and removable lower front window Sliding left front and rear windows with lock Intermittent upper windshield wiper Rain visor Automatic rear window defroster Adjustable PPC wrist control levers for arm, boom, bucket and swing, with sliding proportional control for attachments and auxiliary hydraulic buttons Travel pedals and hand levers Jog shuttle switch with attachment management system 7" (18 cm) LCD colour monitor panel Engine speed (RPM) control dial & fuel control dial Automatic travel speed 4 operating modes & 4 working modes Diesel particulate filter regeneration switch Cigarette lighter and ashtray Ceiling light Cup holder Multiple storage compartments (e.g. document holder under seat) Tool storage area Hot and cool box Flat, spacious, easy-to-clean floor Master key Anti-theft protection Loudspeakers and connections for radio Remote radio ON/OFF switch 12 V spare power socket Serial communication port for laptop PC interface USB port & auxiliary input (MP3 jack)
Safety
Boom and arm cylinder safety valves Overload warning device Large handrails and step Rotating beacon Rear view camera Punched metal anti-slip plates Hydraulic safety lock lever Safety glass Hammer for emergency escape Right and left rearview mirrors Reinforced cast steel pivot points Lockable fuel cap and covers Battery cut-off switch Halogen work lights (2 front frame, 4 front cab-mounted, 2 rear cab-mounted, 2 boom-mounted and 1 rear side) Emergency engine stop and hydraulic pump control switches Engine restart prevention system Parking brake and cab swing lock pin
Other
Boom DX420LC-3: 6.70 m – arm: 3.25 m Boom DX490LC-3: 7.10 m – arm: 3.35 m / DX530LC-3: 6.30 m – arm: 2.90 m Counterweight: DX420LC-3: 8200 kg / DX490LC-3: 8500 kg / DX530LC-3: 11100 kg Auto shut-off fuel filler pump Double element air cleaner and pre-filtered Turbo dust separator Fuel pre-filter with water separator sensor Dust screen for radiator/oil cooler Hydraulically driven reversing oil cooler fan Self-diagnostic function Alternator (12 V, 80 A) Electric horn Hydrostatic 2-speed travel system with automatic shift Remote greasing for swing circle and workgroup pivot points Guards for work lights
Undercarriage
Hydraulic track adjuster Normal track guards Greased and sealed track links 600 mm triple grouser shoe

* Optional equipment

Cab & Interior
MP3/USB radio or MP3/USB radio with CD player
Safety
FOGS cab - top and front cab guards (ISO 10262) Front window upper and lower guards Side view camera
Other
Arms DX420LC-3: 2.60 m, 3.95 m or 3.25 HD - boom: 6.70 m HD Arms DX490LC-3: 2.40 m, 2.90 m, 3.98 m or 3.35 HD - boom: 6.30 or 7.10 m HD Arms DX530LC-3: 2.40 m, 3.98 m, 6.00 m Semi SLR or 8.00 m SLR - boom: 9.00 m Semi SLR or 11.00 m SLR Counterweight DX490LC-3: 9200 kg Heavy-duty bottom cover Doosan buckets: full range of GP, HD & Rock buckets Doosan breakers and Doosan quick-couplers Hydraulic piping for crusher, quick coupler, clamshell, tilting and rotating buckets Additional filter for breaker piping Floating boom function Wiper for lower front window Double pump flow Water separator with heater Engine coolant heater Oil-washed air cleaner Straight travel pedal Telescopic rotating beacon Bio oil Automatic lubrication system Toolkit and spare parts for first service Micro inside cab Air compressor Alarm for travel & swing Additional safety bars (ISO 2867:2011)
Undercarriage
DX420LC-3 narrow fixed width: 3.00 m DX490LC-3 & DX530LC-3: narrow variable width: 2.99 m retracted / 3.49 m extended 600 mm double grouser shoe & 750, 800 & 900 mm triple grouser shoe Full length track guard



Super Long Reach - SLR and Semi SLR
Our long reach machines are ideally suited for land and water based operations with a maximum reach of nearly 20 metres.



Engine coolant heater
Improves start-up ability in extremely cold conditions by heating coolant and fuel.

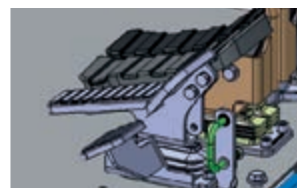

Straight travel pedal
Allows more operator comfort when multi-tasking.



Oil-washed air cleaner
Increases cleaning of the air intake in extra dusty areas such as quarries.



Doosan buckets
A range of dependable new Doosan buckets is available to cover several applications.



Doosan breakers and quick-couplers
Doosan provides the tough, reliable equipment you need for demolition work.

Some of these options may be standard in some markets. Some of these options may not be available for certain markets. Please check with your local DOOSAN dealer for more information about availability or to adapt your machine to your application needs.



Doosan Infracore Construction Equipment

A partner you can trust



**Finance
your
ambitions**



www.doosanequipment.eu

Financial Solutions

Doosan Infracore Financial Services (DI FS) is specialised in creating financing solutions to meet a wide variety of needs. Contact your local dealer for more information.

Always a dealer near you

Our well-developed dealer network has the knowledge and experience to take the best care of our Doosan customers. No matter where you are, you'll get the service you expect - and can rely on!

Parts & Service

- Complete parts & service support for all Doosan products
- Highest quality genuine parts
- Large, dedicated staff of factory-trained aftermarket professionals in the field



www.doosanequipment.eu

