



DX60R - DX80R TECHNICAL DATA





DX60R - DX80R

GENERAL SPECIFICATIONS

ITEMS		UNIT	DX60R	DX80R	
ENGINE	MODEL		Yanmar 4TNV98-ESDB6	Yanmar 4TNV98-ZWDB8	
	NUMBER OF CYLINDERS		4	4	
	RATED FLYWHEEL POWER (hp PER SAE J1995) GROSS	hp / rpm		53 / 2,200	57.8 / 2,000
		kW / rpm		39 / 2,200	42.5 / 2,000
	RATED FLYWHEEL POWER (hp PER SAE J1349) NET	hp / rpm		50.7 / 2,200	54.9 / 2,000
		kW / rpm		37.3 / 2,200	40.4 / 2,000
	MAXIMUM TORQUE (GROSS) (SAE J1995)	ft. lb. / rpm		151.9 / 1,400	182.7 / 1,300
		Nm / rpm		205.9 / 1,400	247.7 / 1,300
	PISTON DISPLACEMENT	in. ³		203	203
		cc		3,319	3,319
	BORE AND STROKE	in. x in.		3.9 x 4.3	3.9 x 4.3
		mm x mm		98 x 110	98 x 110
	STARTER	V / kW		12 V, 3 kW	12 V, 3 kW
BATTERIES	V / AH		1 x 12 V x 100 AH	1 x 12 V x 100 AH	
AIR CLEANER			Double element with auto dust evacuation.	Double element with auto dust evacuation.	
MAIN PUMPS – 2 VARIABLE DISPLACEMENT AXIAL PISTON PUMPS MAX. FLOW	US gpm		2 x 13	38	
	L / min.		2 x 49.3	144	
PILOT PUMP (GEAR DESIGN)	MAXIMUM FLOW	US gpm	2.6	5.8	
		L / min.	9.9	22	
	RELIEF PRESSURE	psi	469	512	
		bar	32.4	35	
MAXIMUM SYSTEM PRESSURE	BOOM/ARM/BUCKET (NORMAL MODE)	psi	3,271	4,061	
		bar	226	280	
	TRAVEL	psi	3,271	4,061	
		bar	226	280	
	SWING	psi	2,987	4,061	
		bar	206	280	
UNDERCARRIAGE	UPPER ROLLERS		1 each track (STD. Shoes)	1 each track (STD. Shoes)	
	LOWER ROLLERS		5 each track	5 each track	
	NUMBER OF SHOES (LINKS PER SIDE)		40 each track (Triple Grouser)	39 each track (Triple Grouser)	
	TOTAL LENGTH OF TRACK	ft. in.	6' 6"	7' 3"	
	mm	1,990	2,200		
ENVIRONMENT	SOUND LEVEL (2000/14/EC)	dB(A)	97	98	
	CABIN SOUND LEVEL (ISO 6396)	dB(A)	77	77	
SWING MECHANISM	SWING SPEED	rpm	0 - 9.6	0 - 9.6	
DRIVE SYSTEM	TRAVEL SPEED (FAST/SLOW)	mph	2.4 / 1.3	2.9 / 1.8	
		km / h.	3.9 / 2.1	4.6 / 2.9	
	DRAWBAR PULL	lb.	11,023	13,669	
		kg	5,000	6,200	
	MAXIMUM GRADE	%	58	58	
		°	30	30	

ITEMS		UNIT	DX60R	DX80R
REFILL CAPACITIES	FUEL TANK	US gal.	20.6	30.6
		L	78	116
	COOLING SYSTEM (RADIATOR CAPACITY)	qt.	5.25	4.6
		L	4.97	4.36
	ENGINE OIL	qt.	12.3	12.3
		L	11.6	11.6
	FINAL DRIVE (EACH SIDE)	qt.	1.48	1.16
		L	1.4	1.1
	HYDRAULIC SYSTEM	US gal.	27.7	29.9
		L	105	113
HYDRAULIC TANK	US gal.	17.2	23	
	L	65	87	

WEIGHT

DX60R			
BOOM	9' 6" (2,900 mm)		
BUCKET	0.229 yd. ³ (0.175 m ³)		
SHOE WIDTH	ARM TYPE	OPERATING WEIGHT	GROUND PRESSURE
15.7" (400 mm) Triple Grouser	4' 10" (1,480 mm)	13,283 lb. (6,025 kg)	4.84 psi (0.33 bar)
	6' 3" (1,900 mm)	13,536 lb. (6,140 kg)	4.98 psi (0.34 bar)
15.7" (400 mm) Rubber Track	4' 10" (1,480 mm)	12,952 lb. (5,875 kg)	4.69 psi (0.32 bar)
	6' 3" (1,900 mm)	13,206 lb. (5,990 kg)	4.84 psi (0.33 bar)

DX80R			
BOOM	11' 1" (3,380 mm)		
BUCKET	0.366 yd. ³ (0.28 m ³)		
SHOE WIDTH	ARM TYPE	OPERATING WEIGHT	GROUND PRESSURE
17.7" (450 mm) Triple Grouser	5' 7" (1,700 mm)	18,475 lb. (8,380 kg)	5.55 psi (0.38 bar)
	7' 5" (2,250 mm)	18,607 lb. (8,440 kg)	5.55 psi (0.38 bar)
17.7" (450 mm) Rubber Track	5' 7" (1,700 mm)	18,365 lb. (8,330 kg)	5.55 psi (0.38 bar)
	7' 5" (2,250 mm)	18,497 lb. (8,390 kg)	5.55 psi (0.38 bar)

HYDRAULIC CYLINDERS

The piston rods and cylinder bodies are made of high-strength steel. A shock absorbing mechanism is fitted in all cylinders to ensure shock-free operation and extend piston life.

DX60R		
CYLINDERS	QUANTITY	BORE x ROD DIAMETER x STROKE
BOOM	1	4.1" x 2.4" x 2' 5" (105 x 60 x 731 mm)
ARM	1	3.3" x 2.2" x 2' 8" (85 x 55 x 811 mm)
BUCKET	1	3.1" x 2.0" x 2' (80 x 50 x 600 mm)
DOZER	1	4.0" x 2.4" x 7.2" (100 x 60 x 183 mm)
BOOM SWING	1	4.3" x 2.2" x 1' 10" (110 x 55 x 550 mm)

The piston rods and cylinder bodies are made of high-strength steel. A shock absorbing mechanism is fitted in all cylinders to ensure shock-free operation and extend piston life.

DX80R		
CYLINDERS	QUANTITY	BORE x ROD DIAMETER x STROKE
BOOM	1	4.5" x 3.0" x 2' 7" (115 x 75 x 775 mm)
ARM	1	4.0" x 2.6" x 2' 10" (100 x 65 x 866 mm)
BUCKET	1	3.3" x 2.2" x 2' 3" (85 x 55 x 690 mm)
DOZER	2	4.0" x 2.4" x 5.9" (100 x 60 x 149 mm)
BOOM SWING	1	4.3" x 2.4" x 2' 5" (110 x 60 x 738 mm)

BUCKET

DX60R						
CAPACITY		WIDTH		WEIGHT	RECOMMENDATIONS	
SAE, HEAPED	CECE, HEAPED	WITHOUT SIDE CUTTERS	WITH SIDE CUTTERS		9' 6" (2,900 mm) BOOM	
					4' 10" (1,480 mm) ARM	6' 3" (1,900 mm) ARM
0.092 yd. ³ (0.07 m ³)	0.078 yd. ³ (0.06 m ³)	11.8" (300 mm)	14.3" (362 mm)	206 lb. (93.5 kg)	A	A
0.229 yd. ³ (0.175 m ³)	0.196 yd. ³ (0.15 m ³)	25.7" (654 mm)	28.5" (724 mm)	311 lb. (141 kg)	A	B

DX80R						
CAPACITY		WIDTH		WEIGHT	RECOMMENDATIONS	
SAE, HEAPED	CECE, HEAPED	WITHOUT SIDE CUTTERS	WITH SIDE CUTTERS		11' 1" (3,380 mm) BOOM	
					5' 7" (1,700 mm) ARM	7' 5" (2,250 mm) ARM
0.26 yd. ³ (0.20 m ³)	0.24 yd. ³ (0.18 m ³)	21.3" (540 mm)	25.4" (646 mm)	439.4 lb. (199.3 kg)	A	A
0.37 yd. ³ (0.28 m ³)	0.31 yd. ³ (0.24 m ³)	27.8" (707 mm)	32" (812 mm)	456 lb. (206.8 kg)	A	B

A. Suitable for materials with density of 2,000 kg•m³ (3,370 lb. / yd.³) or less

B. Suitable for materials with density of 1,600 kg•m³ (2,700 lb. / yd.³) or less

C. Suitable for materials with density of 1,100 kg•m³ (1,850 lb. / yd.³) or less

DIGGING FORCE (ISO)

DX60R		
BUCKET (PCSA)	0.092 yd. ³ (0.07 m ³)	0.229 yd. ³ (0.175 m ³)
DIGGING FORCE	8,973 lbf.	8,973 lbf.
	4,070 kgf.	4,070 kgf.
	39.9 kN	39.9 kN

DX60R		
ARM	4' 10" (1,480 mm) ARM	6' 3" (1,900 mm) ARM
DIGGING FORCE	5,842 lbf.	5,071 lbf.
	2,650 kgf.	2,300 kgf.
	26.0 kN	22.6 kN

DX80R		
BUCKET (PCSA)	0.26 yd. ³ (0.20 m ³)	0.37 yd. ³ (0.28 m ³)
DIGGING FORCE	12,346 lbf.	12,346 lbf.
	5,600 kgf.	5,600 kgf.
	54.9 kN	54.9 kN

DX80R		
BUCKET (PCSA)	5' 7" (1,700 mm) ARM	7' 5" (2,250 mm) ARM
DIGGING FORCE	9,259 lbf.	7,716 lbf.
	4,200 kgf.	3,500 kgf.
	41.2 kN	34.3 kN

DIMENSIONS

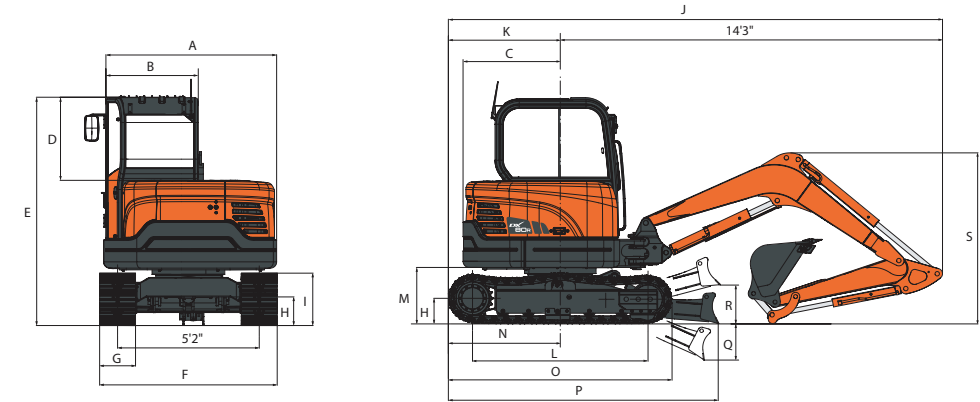

BOOM TYPE	DX60R		DX80R		
	9' 6" (2,900 mm) BOOM		11' 1" (3,380 mm) BOOM		
ARM TYPE	4' 10" (1,480 mm) ARM	6' 3" (1,900 mm) ARM	5' 7" (1,700 mm) ARM	7' 5" (2,250 mm) ARM	
BUCKET TYPE (SAE)	0.229 yd. ³ (0.175 m ³)	0.229 yd. ³ (0.175 m ³)	0.37 yd. ³ (0.28 m ³)	0.26 yd. ³ (0.20 m ³)	
OVERALL WIDTH OF UPPER STRUCTURE	A	6' 4" (1,930 mm)	←	7' 5" (2,266 mm)	
CAB WIDTH	B	3' 5" (1,030 mm)	←	3' 5" (1,030 mm)	
DISTANCE FROM CABIN TO COUNTERWEIGHT	C	2' 11" (900 mm)	←	4' 1" (1,236 mm)	
HEIGHT FROM BONNET TO CABIN	D	3' (927 mm)	←	3' (923 mm)	
OVERALL HEIGHT OF CAB	E	8' 4" (2,550 mm)	←	8' 8" (2,638 mm)	
OVERALL TRACK WIDTH	F	6' 6" (1,980 mm)	←	7' 7" (2,300 mm)	
TRACK SHOE WIDTH	G	1' 4" (400 mm)	←	1' 6" (450 mm)	
GROUND CLEARANCE	H	1' 1" (320 mm)	←	1' 2" (362 mm)	
TRACK HEIGHT	I	1' 11" (580 mm)	←	2' 2" (648 mm)	
OVERALL LENGTH	J	18' 3" (5,565 mm)	18' 5" (5,620 mm)	20' 3" (6,167 mm)	20' 7" (6,267 mm)
TAIL LENGTH	K	3' 7" (1,102 mm)	←	4' 3" (1,298 mm)	←
TUMBLER DISTANCE	L	6' 6" (1,990 mm)	←	7' 3" (2,200 mm)	←
TAIL TO TRACK CLEARANCE	M	- 7" (- 168 mm)	←	- 3" (- 72 mm)	←
END DISTANCE OF TRACK	N	4' 2" (1,270 mm)	←	4' 6" (1,370 mm)	←
TRACK LENGTH	O	8' 4" (2,550 mm)	←	9' 3" (2,823 mm)	←
TRACK TO DOZER LENGTH	P	10' 1" (3,080 mm)	←	10' 9" (3,282 mm)	←
HEIGHT OF DOZER DOWN	Q	1' 4" (415 mm)	←	1' 0" (304 mm)	←
HEIGHT OF DOZER UP	R	1' 5" (435 mm)	←	1' 6" (446 mm)	←
BOOM HEIGHT	S	6' 1" (1,865 mm)	7' 2" (2,188 mm)	6' 10" (2,085 mm)	7' 11" (2,409 mm)

STANDARD EQUIPMENT DX60R

ENGINE:

- Yanmar 4TNV98:
 - Naturally Aspirated, Direct Injection
- 202.5 cu.in., 4 Cylinder
- 50.7 net Flywheel Horsepower @ 2,200 rpm
- Radiator Reserve Tank
- Electric Engine Speed Control

HYDRAULIC SYSTEM:

- Control Valve:
 - Pilot Operated, (12) Spools
- Main Pump:
 - Tandem Variable Piston+Gear (2-13+9.4 US gpm)
 - Pressure Setting 230 kgf. / cm² (3,271) psi for Implements
 - Pressure Setting 210 kgf. / cm² (2,990) psi for Swing
 - Boom Swing and Dozer
- Pilot Circuit:
 - Gear Type Pump (2.6 US gpm)
- Swing Motor
 - Axial Piston Type, 2 Stage Planetary
 - Swing Speed Control up to 9.6 rpm
 - Parking Brake
- Travel Motors:
 - Axial Piston, Planetary
- Travel Speed (High / Low), 2.4 mph / 1.3 mph
- Parking Brake
- Extra Auxiliary Spool
- Overload Relief Valves
- Main Relief Valves
- Hydraulic Kit for 1-Way Applications with Piping to Arm End

CAB:

- Steel, All Weather
- Air Conditioner with Heater, R134a Refrigerant
- AM/FM Stereo Radio (Std.), with Cassette (Opt.)
- Cigarette Lighter
- Cab Door Lock
- Front Windshield Wiper with Washer
- Safety Glass, Tinted
- Controls :
 - Safety Lock Lever
- Seat:
 - Deluxe Reclining with Seat Belt (2" Wide)

- Reclining, Height Adjustable
- Fully Adjustable Arm Rests
- Tilting / Sliding Control Console
- Load Adjustment Knob
- Suspension
- Skylight
- Slide-Up Front Window
- Sliding Side Windows
- Travel Control: Hand Levers / Foot Pedals
- Emergency Breakout Tool

ELECTRICAL:

- Alternator:
 - 60 Amp
- Batteries:
 - (1) 12V, 100 Amp Hrs, 750 CCA ea.
- Starter:
 - 12V, 3.0 kW
- Horn
- Lights:
 - (2) Boom
 - (1) Cabin (Opt.)
- Alarm Buzzer for:
 - Engine Overheat
 - Engine Oil Pressure
 - Overload (Opt.)
- Electronic Monitor for:
 - Engine Oil Pressure Warning
 - Charge Warning
 - Engine Coolant Temperature Warning
 - Air Cleaner Clogging Warning
 - Fuel Level Warning
 - Preheat Indicator
 - High Travel Indicator
 - Engine Check Warning
 - Working Light Indicator
 - Overload Warning
 - Water In Fuel Warning
 - Quick Clamp Indicator
- Instrumentation:
 - Water Temperature Gauge
 - Fuel Gauge
 - Hour Meter

UNDERCARRIAGE:

- Track Adjusters
- Track Rollers:
 - (1) Upper, (5) Lower Each Side
- Triple Grouser Shoes
 - 40 Each Side, (400 mm) Width
- Dozer, Front (1) Cylinder: 6' 6" x 1' 2" (1980 x 350mm)

OTHER STANDARD EQUIPMENT:

- Joystick Pattern Change Valve
- Air Cleaner (Dual Filter)
- Counterweight:
 - 1,765 lb. (800 kg.)
- Sealed Pins and Bucket Linkages
- Joystick Levers with 3 Switches
- Dozer Blade
- Joystick Lever, Dozer
- Swing Boom (Left: 70 Degrees, Right: 50 Degrees)
- Control Pedal, Swing Boom, Tilting
- Manuals:
 - Parts, Operation & Maintenance Manual

OPTIONAL EQUIPMENT DX60R

DOOSAN BUCKET - FACTORY INSTALLED

29" 0.175 mm (0.23 yd.³)

ADDITIONAL OPTIONS - FACTORY INSTALLED

Lock Valve

GEITH COUPLERS - DEALER INSTALLED

Hydraulic Quick Coupler
Manual Quick Coupler

GEITH THUMBS - DEALER INSTALLED

Hydraulic Direct Mount Thumb
Mechanical Thumb

HYDRAULIC KITS - DEALER INSTALLED

Breaker / Thumb (BT) Single & Double Acting HKX

OTHER - ADDITIONAL OPTIONS - DEALER INSTALLED

3" Seat Belt

STANDARD EQUIPMENT DX80R

ENGINE:

Yanmar 4TNV98:
 – Naturally Aspirated, Direct Injection
 202.5 cu.in., 4 Cylinder
 54.9 Net Flywheel Horsepower @ 2,000 rpm
 Radiator Reserve Tank
 Electric Engine Speed Control

HYDRAULIC SYSTEM:

Control Valve:
 – Pilot Operated, (9) Spools
 Main Pump:
 – Load Sensing Tandem Variable Piston (38 US gpm)
 Pressure Setting 300 kgf. / cm²(4,061) psi
 Pilot Circuit:
 – Gear Type Pump (5.8 US gpm)
 Swing Motor:
 – Axial Piston Type, 2 Stage Planetary
 Swing Speed Control up to 9.6 rpm
 Parking Brake
 Travel Motors:
 – Axial Piston, 3 Stage Planetary
 Travel Speed (High / Low), 2.9 mph / 1.8 mph
 Parking Brake
 Extra Auxiliary Spool
 Overload Relief Valves
 Main Relief Valves
 Load Sensing System
 Combination Hydraulic Kit for 1-Way or 2-Way Applications with Piping to Arm End
 with One / Two Way Selection Valve

CAB:

Steel, All Weather
 Air Conditioner with Heater, R134a Refrigerant
 AM/FM Stereo Radio (Std.), with Cassette (Opt.)
 Cigarette Lighter
 Cab Door Lock
 Front Windshield Wiper with Washer
 Safety Glass, Tinted
 Controls - Safety Lock Lever
 Seat:
 – Deluxe Reclining with Seat Belt (2" Wide)
 – Reclining, Height Adjustable

– Fully Adjustable Arm Rests
 – Tilting / Sliding Control Console
 – Load Adjustment Knob
 – Suspension
 Skylight
 Slide-Up Front Window
 Sliding Side Windows
 Travel Control: Hand Levers / Foot pedals
 Emergency Breakout Tool

ELECTRICAL:

Alternator:
 – 60 Amp
 Batteries:
 – (1) 12V, 100 Amp Hrs, 750 CCA ea.
 Starter:
 – 12V, 3.0 kW
 Horn
 Lights:
 – (2) Boom
 – (1) Cabin (Opt.)
 Alarm Buzzer for:
 – Engine Overheat
 – Engine Oil Pressure
 – Overload (Opt.)
 Electronic Monitor for:
 – Engine Oil Pressure Warning
 – Charge Warning
 – Engine Coolant Temperature Warning
 – Air Cleaner Clogging Warning
 – Fuel Level Warning
 – Preheat Indicator
 – High Travel Indicator
 – Engine Check Warning
 – Working Light Indicator
 – Overload Warning
 – Water in Fuel Warning
 – Quick Clamp Indicator
 Instrumentation:
 – Water Temperature Gauge
 – Fuel Gauge
 – Hour Meter

UNDERCARRIAGE:

Track Adjusters
 Track Rollers:
 – (1) Upper, (5) Lower Each Side
 Triple Grouser Shoes
 39 Each Side, (450 mm) Width
 Dozer, Front (1) Cylinder: 7' 7" x 1' 5" (2300 x 440 mm)

OTHER STANDARD EQUIPMENT:

Joystick Pattern Change Valve
 Air Cleaner (Dual Filter)
 Counterweight:
 – 2,805 lb. (1,273 kg.)
 Sealed Pins and Bucket Linkages
 Joystick Levers with 3 Switches
 Dozer Blade
 Joystick Lever, Dozer
 Swing Boom (Left: 71 Degrees, Right: 54 Degrees)
 Control Pedal, Swing Boom, Breaker
 Manuals:
 – Parts, Operation & Maintenance Manual

OPTIONAL EQUIPMENT DX80R

DOOSAN BUCKET - FACTORY INSTALLED

32" 0.24 mm (0.31 yd.³)

ADDITIONAL OPTIONS - FACTORY INSTALLED

Lock Valve

GEITH COUPLERS - DEALER INSTALLED

Hydraulic Quick Coupler
 Manual Quick Coupler

GEITH THUMBS - DEALER INSTALLED

Hydraulic Direct Mount Thumb
 Mechanical Thumb

OTHER - ADDITIONAL OPTIONS - DEALER INSTALLED

3" Seat Belt

LIFTING CAPACITY (DX60R)

Boom: 9'6" (2,900 mm)
Arm: 4'10" (1,480 mm)
Bucket: SAE .24 yd³ (.18 m³)
Rubber Shoe: 15.75" (400 mm)
Counterweight: .89 ton (.81 metric ton)
Dozer Up

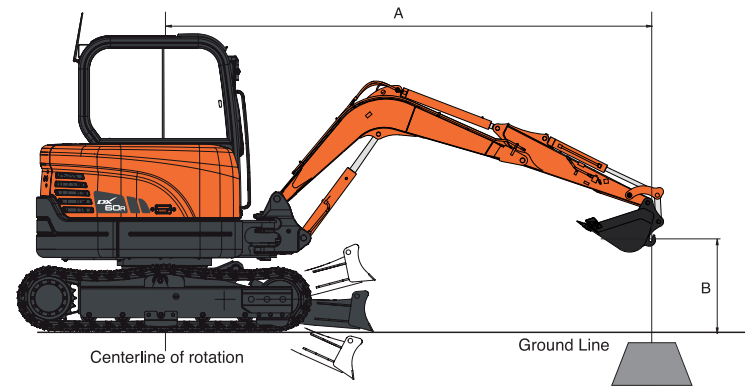

Unit: 1,000 lb.

Feet B (ft.)	A (ft.)		10		15		MAX. REACH		A (ft.)
	Rating Over Front	Rating Over Side or 360 degree	Rating Over Front	Rating Over Side or 360 degree	Rating Over Front	Rating Over Side or 360 degree	Rating Over Front	Rating Over Side or 360 degree	
15					3.27*	1.52	11.66		
10			2.63	1	2.42	0.9	15.77		
5	4.64	1.64	2.55	0.93	2.09	0.74	17.15		
0 (GROUND)	4.43	1.47	2.47	0.86	2.14	0.75	16.66		
-5	4.45	1.48			2.72	0.96	14.05		

Boom: 9'6" (2,900 mm)
Arm: 4'10" (1,480 mm)
Bucket: SAE .24 yd³ (.18 m³)
Rubber Shoe: 15.75" (400 mm)
Counterweight: .89 ton (.81 metric ton)
Dozer Down

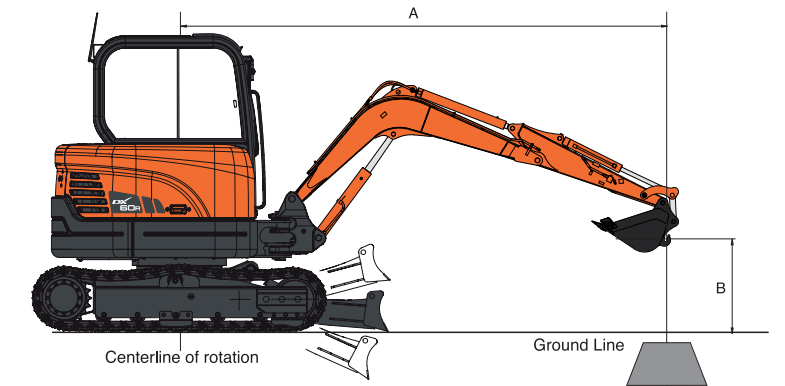

Unit: 1,000 lb.

Feet B (ft.)	A (ft.)		10		15		MAX. REACH		A (ft.)
	Rating Over Front	Rating Over Side or 360 degree	Rating Over Front	Rating Over Side or 360 degree	Rating Over Front	Rating Over Side or 360 degree	Rating Over Front	Rating Over Side or 360 degree	
15					3.12*	2.72	11.66		
10			2.92*	1.83	2.61*	1.68	15.77		
5	5.40*	3.12	3.34*	1.76	2.65*	1.44	17.15		
0 (GROUND)	6.56*	2.92	3.71*	1.68	3.13*	1.46	16.66		
-5	5.63*	2.94			3.30*	1.85	14.05		

Unit: 1,000 kg

Metric B (m)	A (m)		2		3		4		5		MAX. REACH		A (m)
	Rating Over Front	Rating Over Side or 360 degree	Rating Over Front	Rating Over Side or 360 degree	Rating Over Front	Rating Over Side or 360 degree	Rating Over Front	Rating Over Side or 360 degree	Rating Over Front	Rating Over Side or 360 degree	Rating Over Front	Rating Over Side or 360 degree	
4					1.39*	0.58	4.17						
3					1.40*	0.57	4.83						
2			2.22	0.81	1.43	0.53	1.02	0.37	0.97	0.35	5.16		
1			2.11	0.72	1.38	0.49	1	0.36	0.94	0.33	5.24		
0 (GROUND)			2.06	0.68	1.35	0.47	0.99	0.35	0.97	0.34	5.08		
-1	2.81*	1.22	2.06	0.68	1.34	0.46			1.1	0.38	4.65		
-2	3.73*	1.26	2.09	0.7					1.46	0.51	3.83		

Unit: 1,000 kg

Metric B (m)	A (m)		2		3		4		5		MAX. REACH		A (m)
	Rating Over Front	Rating Over Side or 360 degree	Rating Over Front	Rating Over Side or 360 degree	Rating Over Front	Rating Over Side or 360 degree	Rating Over Front	Rating Over Side or 360 degree	Rating Over Front	Rating Over Side or 360 degree	Rating Over Front	Rating Over Side or 360 degree	
4					1.32*	1.03	4.17						
3					1.34*	1.02	4.83						
2			2.13*	1.5	1.58*	0.99	1.38*	0.71	1.18*	0.67	5.16		
1			2.84*	1.4	1.85*	0.94	1.46*	0.69	1.25*	0.64	5.24		
0 (GROUND)			3.05*	1.36	2.01*	0.91	1.49*	0.68	1.42*	0.66	5.08		
-1	2.70*	2.58	2.86*	1.35	1.93*	0.91			1.49*	0.75	4.65		
-2	3.55*	2.63	2.24*	1.38					1.48*	0.99	3.83		

- LOAD POINT IS THE END OF THE ARM.
- CAPACITIES MARKED WITH AN ASTERISK (*) ARE LIMITED BY HYDRAULIC CAPACITIES.
- LIFT CAPACITIES SHOWN DO NOT EXCEED 75% OF MINIMUM TIPPING LOADS OR 87% OF HYDRAULIC CAPACITIES.
- THE LEAST STABLE POSITION IS OVER THE SIDE.
- THE TOTAL MASS OF MACHINE IS 5,900 kg INCLUDED IN THIS MASS BOOM 2.90 m, ARM 1.48 m, 805 kg COUNTERWEIGHT, BUCKET WEIGHT 0 kg, ALL OPERATING FLUIDS AND A 75 kg OPERATOR.
- LIFT CAPACITIES ARE IN COMPLIANCE WITH ISO 10567.

Rating Over Front
 Rating Over Side or 360 degree

- LOAD POINT IS THE END OF THE ARM.
- CAPACITIES MARKED WITH AN ASTERISK (*) ARE LIMITED BY HYDRAULIC CAPACITIES.
- LIFT CAPACITIES SHOWN DO NOT EXCEED 75% OF MINIMUM TIPPING LOADS OR 87% OF HYDRAULIC CAPACITIES.
- THE LEAST STABLE POSITION IS OVER THE SIDE.
- THE TOTAL MASS OF MACHINE IS 5,900 kg INCLUDED IN THIS MASS BOOM 2.90 m, ARM 1.48 m, 805 kg COUNTERWEIGHT, BUCKET WEIGHT 0 kg, ALL OPERATING FLUIDS AND A 75 kg OPERATOR.
- LIFT CAPACITIES ARE IN COMPLIANCE WITH ISO 10567.

Rating Over Front
 Rating Over Side or 360 degree

LIFTING CAPACITY (DX60R)

Boom: 9'6" (2,900 mm)
Arm: 6'3" (1,900mm)
Bucket: SAE .24 yd³ (.18 m³)
Triple Grouser Shoe: 15.75" (400 mm)
Counterweight: .89 ton (.81 metric ton)
Dozer Up

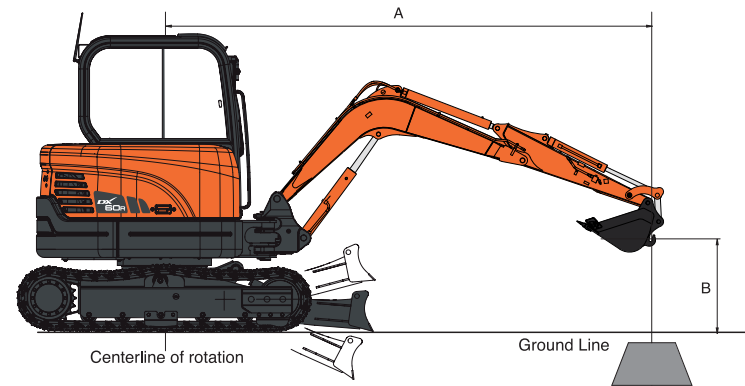

Unit: 1,000 lb.

Feet B (ft.)	A (ft.)		10		15		MAX. REACH		A (ft.)
15					2.58*	1.21	13.53		
10			2.63*	1.01	2.14	0.78	17.09		
5	4.7	1.68	2.55	0.92	1.88	0.64	18.35		
0 (GROUND)	4.4	1.43	2.44	0.83	1.91	0.64	17.90		
-5	4.36	1.41	2.43	0.81	2.31	0.78	15.55		
-10			3.06*	1.69	9.46				

Boom: 9'6" (2,900 mm)
Arm: 6'3" (1,900mm)
Bucket: SAE .24 yd³ (.18 m³)
Triple Grouser Shoe: 15.75" (400 mm)
Counterweight: .89 ton (.81 metric ton)
Dozer Down

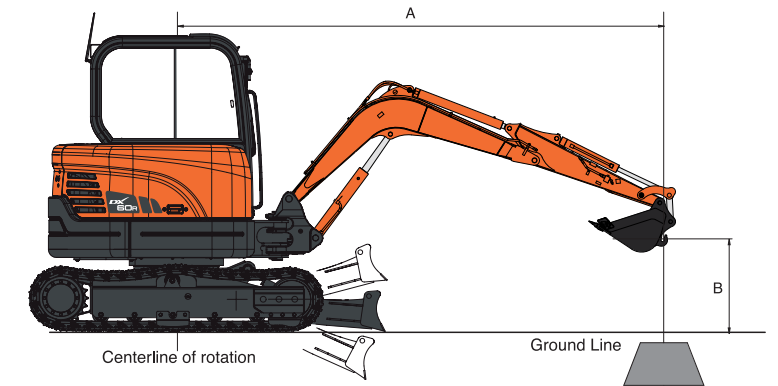

Unit: 1,000 lb.

Feet B (ft.)	A (ft.)		10		15		MAX. REACH		A (ft.)
15					2.46*	2.17	13.53		
10			2.50*	1.84	2.14*	1.48	17.09		
5	4.62*	3.17	3.05*	1.75	2.19*	1.28	18.35		
0 (GROUND)	6.39*	2.89	3.60*	1.65	2.56*	1.29	17.90		
-5	6.04*	2.86	3.34*	1.64	3.08*	1.56	15.55		
-10			2.90*	2.90*	9.46				

Unit: 1,000 kg

Metric B (m)	A (m)		2		3		4		5		MAX. REACH		A (m)
5									1.28*	0.69	3.59		
4					1.11*	0.59			1.08*	0.44	4.64		
3					1.18*	0.58	1.04	0.38	0.96	0.35	5.23		
2			1.82*	0.83	1.44	0.54	1.02	0.37	0.87	0.3	5.53		
1			2.12	0.73	1.38	0.49	1	0.35	0.84	0.28	5.60		
0 (GROUND)	1.34*	1.15	2.04	0.66	1.34	0.45	0.98	0.33	0.87	0.29	5.46		
-1	2.52*	1.16	2.02	0.65	1.32	0.44	0.97	0.32	0.96	0.32	5.07		
-2	4.21*	1.19	2.04	0.66	1.33	0.45			1.19	0.41	4.35		
-3	2.47*	1.27							1.41*	0.72	2.99		

Unit: 1,000 kg

Metric B (m)	A (m)		2		3		4		5		MAX. REACH		A (m)
5									1.22*	1.22*	3.59		
4					1.05*	1.05			1.03*	0.81	4.64		
3					1.13*	1.03	1.16*	0.72	0.97*	0.66	5.23		
2			1.73*	1.53	1.39*	0.99	1.24*	0.7	0.97*	0.6	5.53		
1			2.55*	1.41	1.71*	0.94	1.37*	0.68	1.03*	0.57	5.60		
0 (GROUND)	1.29*	1.29*	2.98*	1.34	1.94*	0.9	1.47*	0.66	1.16*	0.59	5.46		
-1	2.42*	2.42*	2.96*	1.32	1.97*	0.88	1.41*	0.66	1.37*	0.65	5.07		
-2	4.04*	2.55	2.55*	1.34	1.69*	0.89			1.42*	0.8	4.35		
-3	2.34*	2.34*							1.34*	1.34*	2.99		

- LOAD POINT IS THE END OF THE ARM.
- CAPACITIES MARKED WITH AN ASTERISK (*) ARE LIMITED BY HYDRAULIC CAPACITIES.
- LIFT CAPACITIES SHOWN DO NOT EXCEED 75% OF MINIMUM TIPPING LOADS OR 87% OF HYDRAULIC CAPACITIES.
- THE LEAST STABLE POSITION IS OVER THE SIDE.
- THE TOTAL MASS OF MACHINE IS 5,900 KG INCLUDED IN THIS MASS BOOM 2.90 M , ARM 1.90 M ,805 KG COUNTERWEIGHT, BUCKET WEIGHT 0 KG , ALL OPERATING FLUIDS AND A 75 KG OPERATOR.
- LIFT CAPACITIES ARE IN COMPLIANCE WITH ISO 10567.

: Rating Over Front
: Rating Over Side or 360 degree

- LOAD POINT IS THE END OF THE ARM.
- CAPACITIES MARKED WITH AN ASTERISK (*) ARE LIMITED BY HYDRAULIC CAPACITIES.
- LIFT CAPACITIES SHOWN DO NOT EXCEED 75% OF MINIMUM TIPPING LOADS OR 87% OF HYDRAULIC CAPACITIES.
- THE LEAST STABLE POSITION IS OVER THE SIDE.
- THE TOTAL MASS OF MACHINE IS 5,900 KG INCLUDED IN THIS MASS BOOM 2.90 M , ARM 1.90 M ,805 KG COUNTERWEIGHT, BUCKET WEIGHT 0 KG , ALL OPERATING FLUIDS AND A 75 KG OPERATOR.
- LIFT CAPACITIES ARE IN COMPLIANCE WITH ISO 10567.

: Rating Over Front
: Rating Over Side or 360 degree

LIFTING CAPACITY (DX80R)

Boom: 11'1" (3,380 mm)

Arm: 5'7" (1,700 mm)

Bucket: SAE 0.37 yd³ (0.28 m³)

Shoe: 1'6" (450 mm)

Counterweight: 1.4 ton (1.27 metric ton)

With Dozer

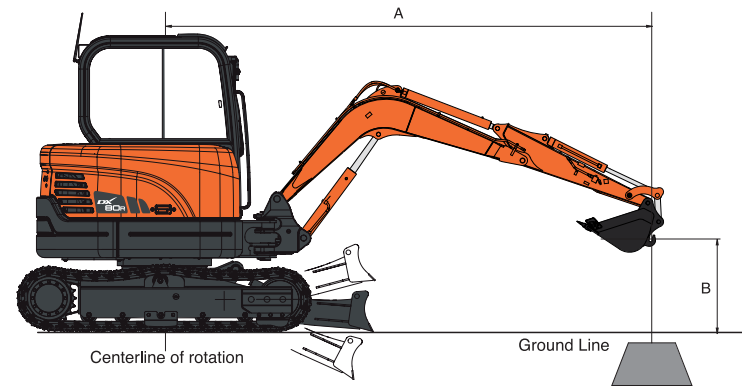

Unit: 1,000 lb.

Feet B (ft.)	A (ft.)		10		15		20		MAX. REACH		A (ft.)
15			2.98*	2.98*			2.79*	2.31	17.1		
10			3.48*	3.11	3.41*	1.89	2.76*	1.8	20.6		
5	7.73*	5.49	4.71*	2.92	3.74*	1.83	3.00*	1.62	21.5		
0 (GROUND)	10.58*	5.05	5.77*	2.75	4.03*	1.76	3.58*	1.65	20.1		
-5	10.27*	4.97	5.84*	2.68			4.07*	1.92	18.1		
-10	7.46*	5.08					4.29*	2.93	14.5		

Boom: 11'1" (3,380 mm)

Arm: 5'7" (1,700 mm)

Bucket: SAE 0.37 yd³ (0.28 m³)

Shoe: 1'6" (450 mm)

Counterweight: 1.4 ton (1.27 metric ton)

Without Dozer

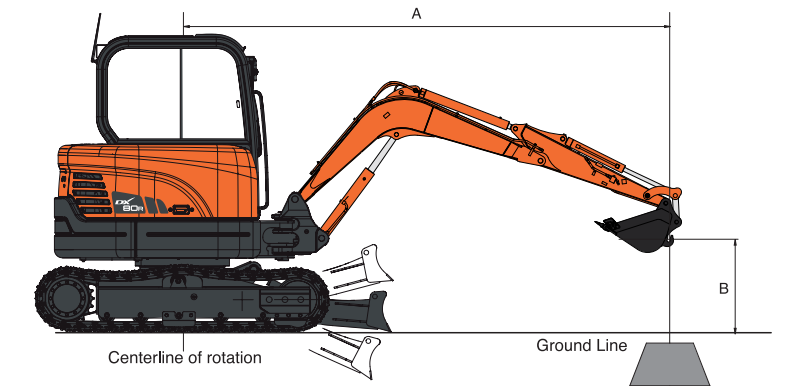

Unit: 1,000 lb.

Feet B (ft.)	A (ft.)		10		15		MAX. REACH		A (ft.)
15					3.83*	3.15	3.59*	2.88	15.9
10					4.19*	3.09	3.58*	2.14	18.8
5	9.36*	5.38	5.29*	2.93	3.98*	1.91	19.8		
0 (GROUND)	10.87*	5.1	6.04*	2.8	4.36*	1.96	19.1		
-5	9.61*	5.1	5.60*	2.77	4.63*	2.37	16.6		
-10	5.47*	5.29			4.57*	4.4	11.3		

Unit: 1,000 kg

Metric B (m)	A (m)		2		3		4		5		6		MAX. REACH		A (m)
5							1.48*	1.23			1.30*	1.17	5.14		
4							1.43*	1.24			1.24*	0.93	5.84		
3					1.62*	1.62*	1.57*	1.21	1.55*	0.88	1.25*	0.81	6.27		
2			2.88*	2.66	2.16*	1.68	1.83*	1.17	1.65*	0.86	1.31*	0.75	6.48		
1			4.26*	2.46	2.75*	1.59	2.12*	1.13	1.78*	0.84	1.43*	0.73	6.51		
0 (GROUND)	1.85*	1.85	4.93*	2.35	3.15*	1.52	2.33*	1.09	1.86*	0.82	1.62*	0.75	6.36		
-1	3.04*	3.04	4.94*	2.31	3.26*	1.49	2.39*	1.07	1.81*	0.81	1.80*	0.81	6.01		
-2	4.51*	4.51	4.49*	2.32	3.05*	1.49	2.19*	1.07			1.88*	0.95	5.41		
-3	5.84*	4.84	3.51*	2.36	2.38*	1.51					1.95*	1.3	4.45		

Unit: 1,000 kg

Metric B (m)	A (m)		2		3		4		5		MAX. REACH		A (m)
5							1.71*	1.71*			1.68*	1.51	4.41
4							1.71*	1.71*	1.75*	1.23	1.60*	1.13	5.23
3							2.04*	1.74	1.85*	1.21	1.63*	0.96	5.71
2					3.75*	2.59	2.55*	1.66	2.07*	1.18	1.73*	0.88	5.95
1					4.93*	2.43	3.05*	1.59	2.30*	1.14	1.90*	0.86	5.98
0 (GROUND)	1.95*	1.95*	4.97*	2.37	3.30*	1.54	2.43*	1.11	1.98*	0.89	1.98*	0.89	5.81
-1	3.73*	3.73*	4.76*	2.36	3.24*	1.53	2.36*	1.1	2.06*	0.98	2.06*	0.98	5.42
-2	5.75*	4.89	4.05*	2.39	2.81*	1.54			2.13*	1.21	2.13*	1.21	4.73
-3	3.96*	3.96*	2.63*	2.46					2.09*	1.92	2.09*	1.92	3.52

: Rating Over Front
: Rating Over Side or 360 degree

1. LOAD POINT IS THE HOOK ON THE BACK OF THE BUCKET.
 2. *RATED LOADS ARE BASED ON HYDRAULIC CAPACITY.
 3. RATED LOADS DO NOT EXCEED 87% OF HYDRAULIC CAPACITY OR 75% OF TIPPING CAPACITY.

: Rating Over Front
: Rating Over Side or 360 degree

1. LOAD POINT IS THE HOOK ON THE BACK OF THE BUCKET.
 2. *RATED LOADS ARE BASED ON HYDRAULIC CAPACITY.
 3. RATED LOADS DO NOT EXCEED 87% OF HYDRAULIC CAPACITY OR 75% OF TIPPING CAPACITY.

LIFTING CAPACITY (DX80R)

Boom: 11'1" (3,380 mm)

Long Arm: 5'7" (2,250 mm)

Bucket: SAE 0.37 yd³ (0.28 m³)

Shoe: 1'6" (450 mm)

Counterweight: 1.4 ton (1.27 metric ton)

With Dozer

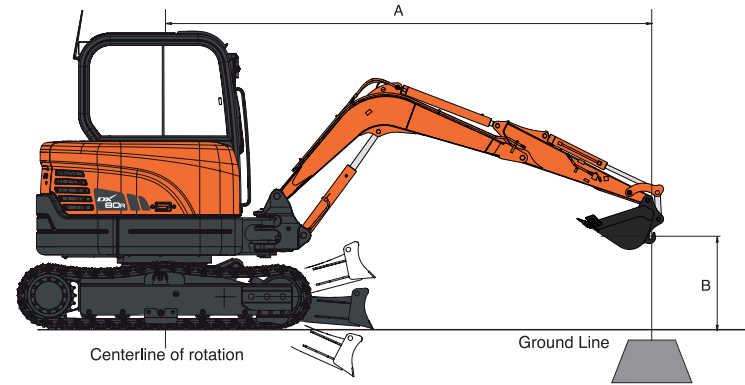

Unit: 1,000 lb.

Feet B (ft.)	A (ft.)											
	5		10		15		20		MAX. REACH			A (ft.)
15							*2.39	*2.39				17.99
10					*3.16	*3.16	*3.03	2.43	*2.29	*2.29		20.51
5			*7.10	*7.10	*4.25	3.80	*3.33	2.34	*2.45	2.07		21.39
0 (GROUND)	*4.78	*4.78	*9.64	6.72	*5.19	3.53	*3.57	2.24	*2.92	2.09		20.87
-5	*8.72	*8.72	*9.27	6.59	*5.22	3.41	*3.57	2.43				18.80
-10	*13.92	*13.92	*6.55	*6.55	*3.69	*3.69						14.38

Unit: 1,000 kg

Metric B (m)	A (m)														
	1		2		3		4		5		6		MAX. REACH		A (m)
5									*1.23	*1.23	*1.03	*1.03			5.14
4									*1.18	*1.18	*0.96	*0.96			5.84
3									*1.29	*1.29	*1.25	1.14	*0.95	*0.95	6.27
2					*2.44	*2.44	*1.80	*1.80	*1.50	*1.50	*1.33	1.11	*0.98	0.96	6.48
1					*3.58	3.31	*2.27	2.07	*1.73	1.45	*1.43	1.07	*1.06	0.93	6.51
0 (GROUND)	*2.16	*2.16	*2.45	*2.45	*4.11	3.13	*2.60	1.97	*1.90	1.39	*1.50	1.04	*1.21	0.95	6.36
-1	*2.95	*2.95	*3.56	*3.56	*4.10	3.07	*2.68	1.92	*1.94	1.36	*1.44	1.03	*1.43	1.03	6.01
-2	*3.96	*3.96	*4.92	*4.92	*3.69	3.08	*2.48	1.91	*1.75	1.35	*1.49	1.21			5.41
-3	*5.19	*5.19	*4.65	*4.65	*2.81	*2.81	*1.87	*1.87	*1.51	*1.51					4.45

1. LOAD POINT IS THE HOOK ON THE BACK OF THE BUCKET.
 2. *RATED LOADS ARE BASED ON HYDRAULIC CAPACITY.
 3. RATED LOADS DO NOT EXCEED 87% OF HYDRAULIC CAPACITY OR 75% OF TIPPING CAPACITY.

: Rating Over Front
: Rating Over Side or 360 degree

Boom: 11'1" (3,380 mm)

Long Arm: 5'7" (2,250 mm)

Bucket: SAE 0.37 yd³ (0.28 m³)

Shoe: 1'6" (450 mm)

Counterweight: 1.4 ton (1.27 metric ton)

Without Dozer

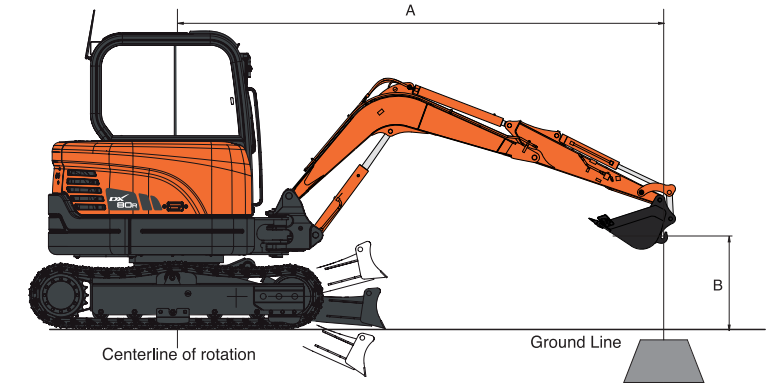

Unit: 1,000 lb.

Feet B (ft.)	A (ft.)											
	5		10		15		20		MAX. REACH			A (ft.)
15												
10												
5												
0 (GROUND)	4.78*	4.78*	9.64*	6.72	5.19*	3.53	3.57*	2.24	2.92*	2.09		20.87
-5	8.72*	8.72*	9.27*	6.59	5.22*	3.41	3.57*	2.43				18.80
-10	13.92*	13.92*	6.55*	6.55*	3.69*	3.69*						14.38

Unit: 1,000 kg

Metric B (m)	A (m)														
	1		2		3		4		5		6		MAX. REACH		A (m)
5															5.14
4															5.84
3															6.27
2															6.48
1															6.51
0 (GROUND)	2.29*	2.29*	2.61*	2.61*	2.69	2.33	1.70	1.50	1.20	1.06	0.89	0.79	0.81	0.72	6.36
-1	3.14*	3.14*	3.79*	3.79*	2.63	2.28	1.64	1.45	1.16	1.03	0.88	0.78	0.87	0.77	6.01
-2	4.23*	4.23*	5.25*	4.84	2.64	2.29	1.64	1.44	1.16	1.03	1.03	0.92			5.41
-3	5.54*	5.54*	5.12*	4.98	2.70	2.35	1.68	1.48	1.43	1.27					4.45

1. LOAD POINT IS THE HOOK ON THE BACK OF THE BUCKET.
 2. *RATED LOADS ARE BASED ON HYDRAULIC CAPACITY.
 3. RATED LOADS DO NOT EXCEED 87% OF HYDRAULIC CAPACITY OR 75% OF TIPPING CAPACITY.

: Rating Over Front
: Rating Over Side or 360 degree

LIFTING CAPACITY (DX80R)

Boom: 11'1" (3,380 mm)

Long Arm: 5'7" (1,700 mm)

Bucket: SAE 0.37 yd³ (0.28 m³)

Rubber Shoe: 1'6" (450 mm)

Counterweight: 1.4 ton (1.27 metric ton)

With Dozer

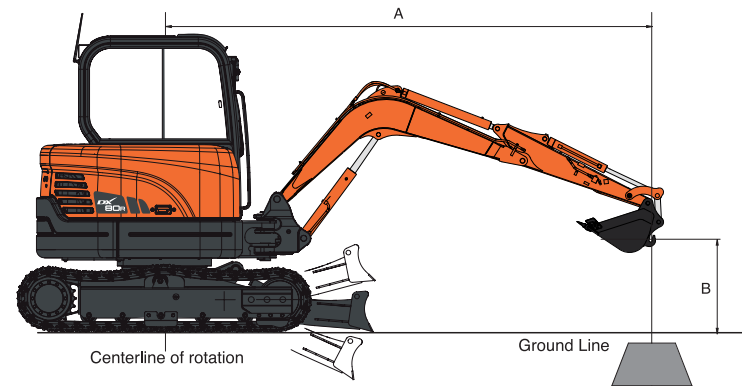

Unit: 1,000 lb.

Feet B (ft.)	A (ft.)		1.181		157.5		196.9		A (ft.)
1.969			3.76*	3.66			3.83*	3.17	14.07
1.575			3.68*	3.68*	3.65*	2.40	3.41*	2.27	16.83
1.181	5.46*	5.46*	4.32*	3.57	3.79*	2.38	3.3*	1.87	18.43
0.787	6.98*	5.34	5.31*	3.37	4.18*	2.29	3.39*	1.70	19.22
0.394	7.93*	4.87	6.17*	3.15	4.58*	2.20	3.68*	1.63	19.32
0(GROUND)	9.85*	4.76	6.5*	3.02	4.73*	2.14	3.81*	1.70	18.76
-0.394	8.99*	4.76	6.21*	3.00	4.43*	2.12	3.85*	1.92	17.42
-0.787	7.29*	4.87	5.07*	3.04			3.76*	2.47	15.12
-1.181	3.74*	3.74*					2.99*	2.99*	10.95

Unit: 1,000 kg

Metric B (m)	A (m)		3		4		5		MAX. REACH A (m)
5			1.71*	1.66			1.74*	1.44	4.29
4			1.67*	1.67*	1.66*	1.09	1.55*	1.03	5.13
3	2.48*	2.48*	1.96*	1.62	1.72*	1.08	1.50*	0.85	5.62
2	3.17*	2.42	2.41*	1.53	1.90*	1.04	1.54*	0.77	5.86
1	3.60*	2.21	2.80*	1.43	2.08*	1.00	1.67*	0.74	5.89
0(GROUND)	4.47*	2.16	2.95*	1.37	2.15*	0.97	1.73*	0.77	5.72
-1	4.08*	2.16	2.82*	1.36	2.01*	0.96	1.75*	0.87	5.31
-2	3.31*	2.21	2.30*	1.38			1.71*	1.12	4.61
-3	1.70*	1.70*					1.36*	1.36*	3.34

1. LOAD POINT IS THE HOOK ON THE BACK OF THE BUCKET.
 2. *RATED LOADS ARE BASED ON HYDRAULIC CAPACITY.
 3. RATED LOADS DO NOT EXCEED 87% OF HYDRAULIC CAPACITY OR 75% OF TIPPING CAPACITY.

: Rating Over Front
: Rating Over Side or 360 degree

Boom: 11'1" (3,380 mm)

Long Arm: 5'7" (1,700 mm)

Bucket: SAE 0.37 yd³ (0.28 m³)

Rubber Shoe: 1'6" (450 mm)

Counterweight: 1.4 ton (1.27 metric ton)

Without Dozer

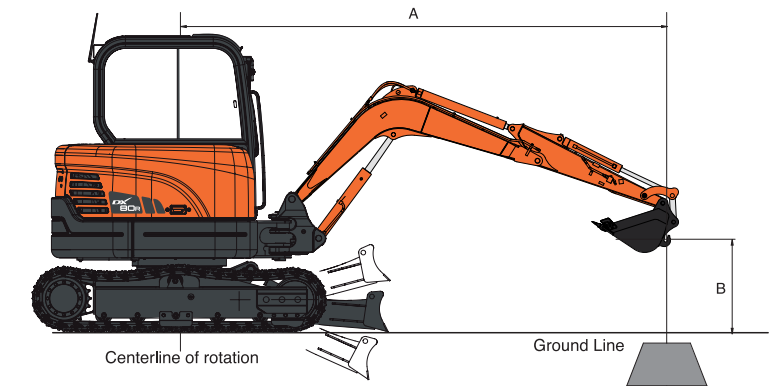

Unit: 1,000 lb.

Feet B (ft.)	A (ft.)		1.181		157.5		196.9		A (ft.)
1.969			3.76*	3.66			3.64	3.17	@14.07
1.575			3.68	3.68*	2.73	2.40	2.58	2.27	@16.83
1.181	5.46*	5.46*	4.08	3.57	2.71	2.38	2.14	1.87	@18.43
0.787	6.26	5.34	3.86	3.37	2.62	2.29	1.94	1.70	@19.22
0.394	5.75	4.87	3.64	3.15	2.54	2.20	1.87	1.63	@19.32
0(GROUND)	5.64	4.76	3.51	3.02	2.45	2.14	1.96	1.70	@18.76
-0.394	5.64	4.76	3.48	3.00	2.43	2.12	2.20	1.92	@17.42
-0.787	5.75	4.87	3.53	3.04			2.84	2.47	@15.12
-1.181	3.74*	3.74*					2.99*	2.99*	@10.95

Unit: 1,000 kg

Metric B (m)	A (m)		3		4		5		MAX. REACH A (m)
5			1.71*	1.66			1.65	1.44	@ 4.29
4			1.67	1.67*	1.24	1.09	1.17	1.03	@ 5.13
3	2.48*	2.48*	1.85	1.62	1.23	1.08	0.97	0.85	@ 5.62
2	2.84	2.42	1.75	1.53	1.19	1.04	0.88	0.77	@ 5.86
1	2.61	2.21	1.65	1.43	1.15	1.00	0.85	0.74	@ 5.89
0(GROUND)	2.56	2.16	1.59	1.37	1.11	0.97	0.89	0.77	@ 5.72
-1	2.56	2.16	1.58	1.36	1.10	0.96	1.00	0.87	@ 5.31
-2	2.61	2.21	1.60	1.38			1.29	1.12	@ 4.61
-3	1.70*	1.70*					1.36*	1.36*	@ 3.34

1. LOAD POINT IS THE HOOK ON THE BACK OF THE BUCKET.
 2. *RATED LOADS ARE BASED ON HYDRAULIC CAPACITY.
 3. RATED LOADS DO NOT EXCEED 87% OF HYDRAULIC CAPACITY OR 75% OF TIPPING CAPACITY.

: Rating Over Front
: Rating Over Side or 360 degree

LIFTING CAPACITY (DX80R)

Boom: 11'1" (3,380 mm)

Long Arm: 5'7" (2,250 mm)

Bucket: SAE 0.37 yd³ (0.28 m³)

Rubber Shoe: 1'6" (450 mm)

Counterweight: 1.4 ton (1.27 metric ton)

With Dozer

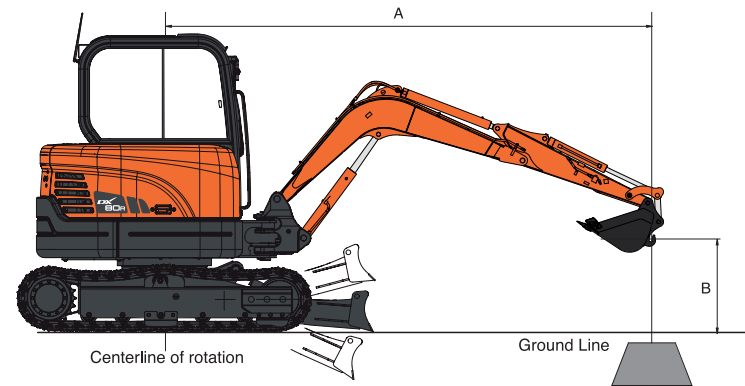

Unit: 1,000 lb.

Feet B (ft.)	A (ft.)		118.1		157.5		196.9		236.2		A (ft.)
	🏗️	🏗️	🏗️	🏗️	🏗️	🏗️	🏗️	🏗️	🏗️	🏗️	
1.969					2.77*	2.40			2.71*	2.38	16.46
1.575					2.95*	2.45			2.46*	1.81	18.79
1.181			3.48*	3.48*	3.21*	2.40	*3.1*	1.63	2.44*	1.52	20.24
0.787	6.45*	5.56	4.54*	3.40	3.7*	2.29	*3.26*	1.59	2.46*	1.39	20.93
0.394	8.92*	4.96	5.62*	3.15	4.21*	2.16	*3.46*	1.54	2.64*	1.34	21.03
0(GR)	9.81*	4.67	6.26*	2.95	4.56*	2.05	*3.54*	1.48	2.97*	1.37	20.53
-0.394	9.52*	4.61	6.3*	2.87	4.56*	2.01			3.37*	1.52	19.35
-0.787	8.35*	4.65	5.68*	2.89	3.92*	2.03			3.41*	1.85	17.32
-1.181	5.99*	4.81	3.88*	3.00					3.24*	2.71	14

Unit: 1,000 kg

Metric B (m)	A (m)		3		4		5		6		MAX. REACH		A (m)
	🏗️	🏗️	🏗️	🏗️	🏗️	🏗️	🏗️	🏗️	🏗️	🏗️	🏗️	🏗️	
5							1.26*	1.09			1.23*	1.08	5.02
4							1.34*	1.11			1.12*	0.82	5.73
3				1.58*	1.58*	1.46*	1.09	1.41*	0.74	1.11*	0.69	0.69	6.17
2	2.93*	2.52	2.06*	1.54	1.68*	1.04	1.48*	0.72	1.12*	0.63	0.63	0.63	6.38
1	4.05*	2.25	2.55*	1.43	1.91*	0.98	1.57*	0.70	1.20*	0.61	0.61	0.61	6.41
0(GROUND)	4.45*	2.12	2.84*	1.34	2.07*	0.93	1.61*	0.67	1.35*	0.62	0.62	0.62	6.26
-1	4.32*	2.09	2.86*	1.30	2.07*	0.91			1.53*	0.69	0.69	0.69	5.90
-2	3.79*	2.11	2.58*	1.31	1.78*	0.92			1.55*	0.84	0.84	0.84	5.28
-3	2.72*	2.18	1.76*	1.36					1.47*	1.23	1.23	1.23	4.27

1. LOAD POINT IS THE HOOK ON THE BACK OF THE BUCKET.
 2. *RATED LOADS ARE BASED ON HYDRAULIC CAPACITY.
 3. RATED LOADS DO NOT EXCEED 87% OF HYDRAULIC CAPACITY OR 75% OF TIPPING CAPACITY.

🏗️: Rating Over Front
 🏗️: Rating Over Side or 360 degree

Boom: 11'1" (3,380 mm)

Long Arm: 5'7" (2,250 mm)

Bucket: SAE 0.37 yd³ (0.28 m³)

Rubber Shoe: 1'6" (450 mm)

Counterweight: 1.4 ton (1.27 metric ton)

Without Dozer

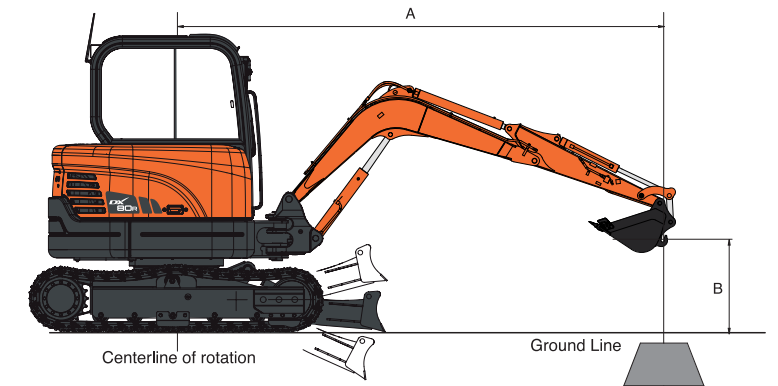

Unit: 1,000 lb.

Feet B (ft.)	A (ft.)		118.1		157.5		196.9		236.2		A (ft.)		
	🏗️	🏗️	🏗️	🏗️	🏗️	🏗️	🏗️	🏗️	🏗️	🏗️			
1.969							2.73	2.40			2.71	2.38	16.46
1.575							2.80	2.45			2.07	1.81	18.79
1.181				3.48*	3.48*	2.73	2.40	1.87	1.63	1.76	1.52	1.52	20.24
0.787	6.45*	5.56	3.90	3.40	2.62	2.29	1.83	1.59	1.61	1.39	1.39	1.39	20.93
0.394	5.86	4.96	3.64	3.15	2.49	2.16	1.79	1.54	1.54	1.34	1.34	1.34	21.03
0(GR)	5.56	4.67	3.44	2.95	2.38	2.05	1.72	1.48	1.61	1.37	1.37	1.37	20.53
-0.394	5.47	4.61	3.35	2.87	2.31	2.01			1.76	1.52	1.52	1.52	19.35
-0.787	5.53	4.65	3.37	2.89	2.34	2.03			2.16	1.85	1.85	1.85	17.32
-1.181	5.71	4.81	3.48	3.00					3.15	2.71	2.71	2.71	14

Unit: 1,000 kg

Metric B (m)	A (m)		3		4		5		6		MAX. REACH		A (m)
	🏗️	🏗️	🏗️	🏗️	🏗️	🏗️	🏗️	🏗️	🏗️	🏗️	🏗️	🏗️	
5							1.24	1.09			1.23	1.08	5.02
4							1.27	1.11			0.94	0.82	5.73
3				1.58*	1.58*	1.24	1.09	0.85	0.74	0.80	0.69	0.69	6.17
2	2.93*	2.52	1.77	1.54	1.19	1.04	0.83	0.72	0.73	0.63	0.63	0.63	6.38
1	2.66	2.25	1.65	1.43	1.13	0.98	0.81	0.70	0.70	0.61	0.61	0.61	6.41
0(GROUND)	2.52	2.12	1.56	1.34	1.08	0.93	0.78	0.67	0.73	0.62	0.62	0.62	6.26
-1	2.48	2.09	1.52	1.30	1.05	0.91			0.80	0.69	0.69	0.69	5.90
-2	2.51	2.11	1.53	1.31	1.06	0.92			0.98	0.84	0.84	0.84	5.28
-3	2.59	2.18	1.58	1.36					1.43	1.23	1.23	1.23	4.27

1. LOAD POINT IS THE HOOK ON THE BACK OF THE BUCKET.
 2. *RATED LOADS ARE BASED ON HYDRAULIC CAPACITY.
 3. RATED LOADS DO NOT EXCEED 87% OF HYDRAULIC CAPACITY OR 75% OF TIPPING CAPACITY.

🏗️: Rating Over Front
 🏗️: Rating Over Side or 360 degree



BRO-DX60R-DX80R-TD

Kn-2M-1210-20997_28-F

For more information visit www.doosanequipment.com



Doosan® is a registered trademark of Doosan Infracore Co., Ltd. in the United States.
© 2010 Doosan Infracore Construction Equipment America. All rights reserved.