

VX Series

Diesel and LP Gas Forklift Trucks

1,600kg, 1,800kg and 2,000kg



- Intellix Vehicle Management System
- CANbus technology
- Supercushion, pneumatic and Michelin XZM radial tyres
- 2 application matched transmissions
- Accutouch minilevers, PalmTech joystick and manual levers

Truck Dimensions

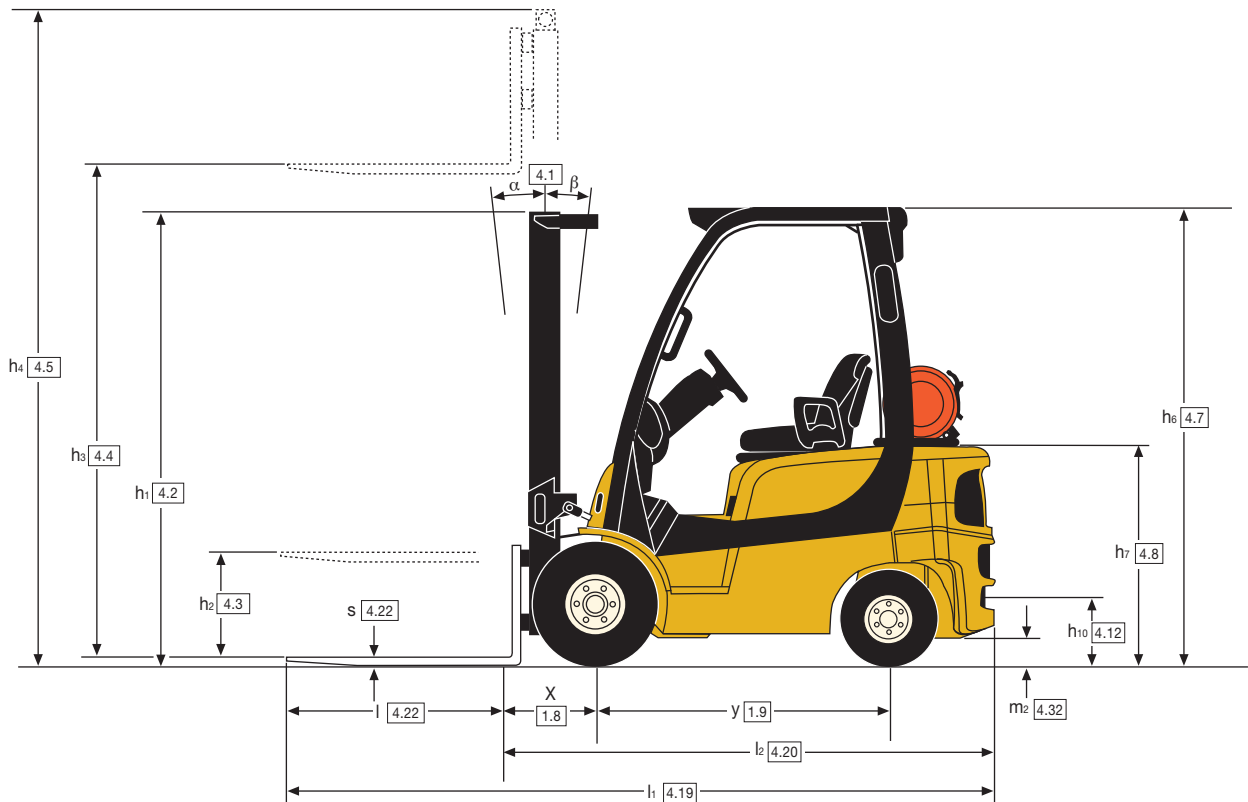
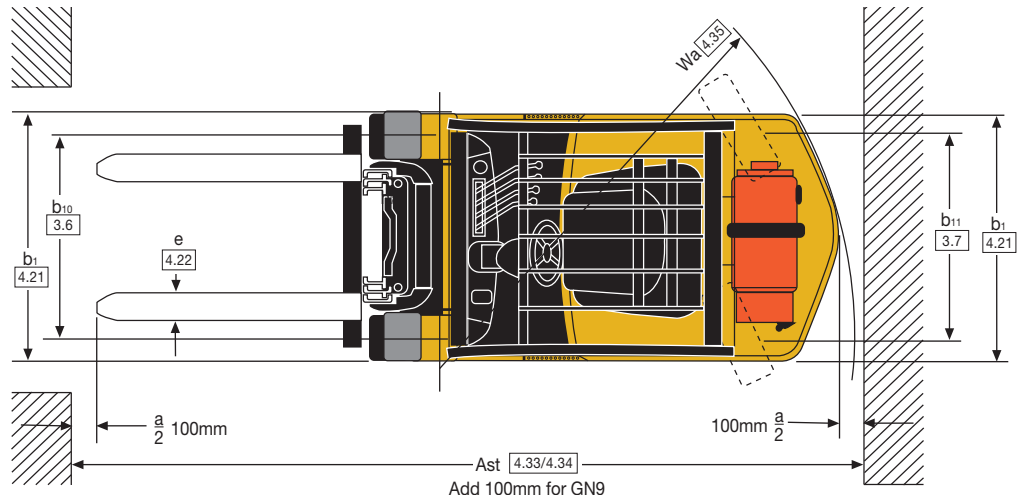

Engine Specifications

Yanmar TNE series - Diesel

Base and Value

4 Cylinder	Overhead Valve
Displacement	2.6 litre
Torque	146Nm @ 2400 RPM
Power	29.1 kW @ 2400 RPM
Air Filtration	Two Stage, Dry Type
IDI fuel injection system	

Mazda FE, LPG

Base

4 Cylinder	Overhead Camshaft
Displacement	2.0 litre
Torque	111 Nm @ 2400 RPM
Power	29.8 kW @ 2600 RPM
Air Filtration	Two Stage, Dry Type
Emission Control	Closed loop

Options

- Powertrain protection system
- Premium monitoring package
- High air intake with pre-cleaner
- Accumulator
- Keyless start (with auxiliary key switch)
- Traction speed limiter
- Heavy-duty "Combi Cooler" radiator
- Swing-out, drop-down EZ-Tank bracket
- Return-to-set tilt
- Swivel full suspension seat
- Foot directional control
- Operator password
- Alarm-reverse
- Amber strobe light - continuous activated
- Impact monitor
- Load weight indicator

Masts

A full range of Yale Hi-Vis™ 2 stage LFL and 2 and 3 stage FFL masts are available.

Yale Hi-Vis™ masts are designed for maximum visibility, with widely spaced channels, lift chains and main lift cylinders.

Mast details and capacity ratings (kg) - Supercushion tyres

Model		GLP/GDP 16 VX										GLP/GDP 18 VX						
Tyres		6.50 x 10										6.50 x 10						
Width across tyres		1068mm										1068mm						
Mast	OAH h1	FFH h2+s	MFH h3+s	h4	Tilt		Forks			Integral Sideshift			Forks			Integral Sideshift		
					F	B	500 LC	600 LC	700 LC	500 LC	600 LC	700 LC	500 LC	600 LC	700 LC	500 LC	600 LC	700 LC
2-Stg. LFL (V)	2175	140	3330	3906	6	5	1600	1560	1420	1600	1480	1350	1800	1670	1510	1750	1580	1440
	2425	140	3830	4406	6	5	1600	1550	1410	1600	1470	1340	1800	1660	1510	1740	1570	1430
	2775	140	4330	4906	6	5	1600	1550	1400	1600	1460	1330	1740	1600	1450	1680	1520	1380
2-Stg. FFL (F)	2125	1551	3215	3792	6	5	1600	1550	1410	1600	1470	1340	1800	1680	1520	1760	1590	1450
3-Stg. FFL (E)	2025	1456	4450	5019	6	3	1570	1500	1360	1570	1410	1290	1740	1600	1450	1680	1510	1380
	2175	1606	4900	5469	6	3	1490	1410	1280	1480	1330	1220	1650	1510	1370	1590	1430	1300
	2425	1856	5500	6069	6	3	1370**	1290**	1170**	1310	1220	1110	1490**	1380**	1250**	1440**	1310**	1190**

** With intermediate width tread drive tyres (1108mm width)- must be specified. h2 and h4 are without load backrest.

Mast details and capacity ratings (kg) - Supercushion tyres

Model		GLP/GDP 20 SVX											
Tyres		6.50 x 10											
Width across tyres		1068mm											
Mast	OAH h1	FFH h2+s	MFH h3+s	h4	Tilt		Forks			Integral Sideshift			
					F	B	500 LC	600 LC	700 LC	500 LC	600 LC	700 LC	
2-Stg. LFL (V)	2175	140	3330	3906	6	5	2000		1880	1700	1970	1780	1620
	2425	140	3830	4406	6	5	2000		1870	1700	1960	1770	1610
	2775	140	4330	4906	6	5	1940		1810	1640	1900	1720	1560
2-Stg. FFL (F)	2125	1551	3215	3792	6	5	2000		1870	1700	1970	1780	1620
FFL (E)	2025	1456	4450	5019	6	3	1910		1790	1630	1880	1700	1550
	2175	1606	4900	5469	6	3	1820		1700	1540	1790	1610	1470
	2425	1856	5500	6069	6	3	1560**		1560**	1420**	1560**	1480**	1350**

** With intermediate width tread drive tyres (1108mm width)- must be specified. h2 and h4 are without load backrest.

Mast details and capacity ratings (kg) - Michelin XZM tyres

Model		GLP/GDP 16 VX										GLP/GDP 18 VX						
Tyres		6.50 R10										6.50 R10						
Width across tyres		1068mm										1068mm						
Mast	OAH h1	FFH h2+s	MFH h3+s	h4	Tilt		Forks			Integral Sideshift			Forks			Integral Sideshift		
					F	B	500 LC	600 LC	700 LC	500 LC	600 LC	700 LC	500 LC	600 LC	700 LC	500 LC	600 LC	700 LC
2-Stg. LFL (V)	2175	140	3330	3906	6	5	1600	1560	1420	1600	1480	1350	1800	1670	1510	1750	1580	1440
	2425	140	3830	4406	6	5	1600	1550	1410	1600	1470	1340	1800	1660	1510	1740	1570	1430
	2775	140	4330	4906	6	5	1600	1550	1400	1600	1460	1330	1740	1600	1450	1680	1520	1380
2-Stg. FFL (F)	2125	1551	3215	3792	6	5	1600	1550	1410	1600	1470	1340	1800	1680	1520	1760	1590	1450
3-Stg. FFL (E)	2025	1456	4450	5019	6	3	1570*	1500*	1360*	1570*	1410*	1290*	1740**	1600**	1450**	1660*	1510*	1380*
	2175	1606	4900	5469	6	3	1490**	1410**	1280**	1480**	1330**	1210**	1650**	1510**	1370**	1580**	1430**	1300**
	2425	1856	5500	6069	6	3	1290**	1280**	1160**	1280**	1210**	1100**	1310**	1310**	1250**	1290**	1290**	1190**

* With intermediate width tread drive tyres (1108mm width)- must be specified. h2 and h4 are without load backrest.

** With intermediate width tread drive tyres (1240mm width)- must be specified. h2 and h4 are without load backrest.

Mast details and capacity ratings (kg) - Michelin XZM tyres

Model		GLP/GDP 20 SVX											
Tyres		6.50 R10											
Width across tyres		1068mm											
Mast	OAH h1	FFH h2+s	MFH h3+s	h4	Tilt		Forks			Integral Sideshift			
					F	B	500 LC	600 LC	700 LC	500 LC	600 LC	700 LC	
2-Stg. LFL (V)	2175	140	3330	3906	6	5	2000		1880	1700	1970	1780	1620
	2425	140	3830	4406	6	5	2000		1870	1700	1960	1770	1610
	2775	140	4330	4906	6	5	1940*		1810*	1640*	1900*	1710*	1560*
2-Stg. FFL (F)	2125	1551	3215	3792	6	5	2000		1870	1700	1970	1780	1620
3-Stg. FFL (E)	2025	1456	4450	5019	6	3	1690*		1670*	1630*	1670*	1660*	1550*
	2175	1606	4900	5469	6	3	1370*		1370*	1370*	1350*	1350*	1340*
	2425	1856	5500	6069	6	3	1040*		1040*	1040**	1010*	1010*	1010*

* With intermediate width tread drive tyres (1108mm width)- must be specified. h2 and h4 are without load backrest.

** With intermediate width tread drive tyres (1240mm width)- must be specified. h2 and h4 are without load backrest.

VDI 2198 – General Specifications, Diesel Powered GDP16VX, GDP18VX, GDP20SVX

		Yale			
		GDP 16 VX			
Characteristics	1.1	Manufacturer			
	1.2	Model designation			
		Power Train - Engine Transmission	Yanmar 2.6L Standard Electronic	Yanmar 2.6L Techtronix 100	
		Model - Manufacturer Designation	Base	Value	
	1.3	Power: battery, diesel, LPG, electric mains	Diesel	Diesel	
	1.4	Operation: manual, pedestrian, stand, seat, order picker	Seat	Seat	
	1.5	Load capacity	Q (kg)	1600	
	1.6	Load centre	c (mm)	500	
	1.8	Load distance	x (mm)	384	
	1.9	Wheelbase	y (mm)	1385	
Weights	2.1	Unladen weight	kg	3059	
	2.2	Axle loading laden, front/rear	kg	3856 / 565	
	2.3	Axle loading unladen, front/rear	kg	1521 / 1538	
Wheels & Tyres	3.1	Tyres: L = Pneumatic, V = Cushion, SE = Supercushion		SE	
	3.2	Tyre size-front		6.50 X 10-10	
	3.3	Tyre size-rear		5.00 X 8	
	3.5	Number of wheels, front/rear (X = driven)		2x/2	
	3.6	Track width, front	b10 (mm)	890	
	3.7	Track width, rear	b11 (mm)	895	
	Dimensions	4.1	Mast tilt, forward α /back β	degrees	6 / 5
4.2		Height of mast, lowered	h1 (mm)	2175	
4.3		Free lift ▲	h2 (mm)	100	
4.4		Lift height ▲	h3 (mm)	3290	
4.5		Height of mast, extended +	h4 (mm)	3906	
4.7		Height to top of overhead guard ○	h6 (mm)	2149	
4.8		Seat height ✕	h7 (mm)	1044	
4.12		Towing coupling height	h10 (mm)	321	
4.19		Overall length	l1 (mm)	3236	
4.20		Length to face of forks	l2 (mm)	2236	
4.21		Overall width	b1 (mm)	1068	
4.22		Fork dimensions	s/e/l (mm)	40 X 80 X 1000	
4.23		Fork carriage to DIN 15173. Class, A/B		IIA	
4.24		Fork carriage width ▽	b3 (mm)	977	
4.31		Ground clearance under mast, laden	m1 (mm)	110	
4.32		Ground clearance at centre of wheelbase	m2 (mm)	146	
Performance		4.33	Aisle width with pallets 1000mm x 1200mm wide	Ast (mm)	3539
		4.34	Aisle width with pallets 800mm x 1200mm long	Ast (mm)	3739
	4.35	Outer turning radius	Wa (mm)	1955	
	4.36	Inner turning radius	b13 (mm)	48	
	5.1	Travel speed laden/unladen	km/h	20.5 / 20.9	
	5.2	Lifting speed laden/unladen	m/sec	0.64 / 0.72	
	5.3	Lowering speed laden/unladen	m/sec	0.51 / 0.47	
	5.5	Maximum drawbar pull laden/unladen,	N	14470 / 7470	
		Drawbar pull laden/unladen, @ 1.6km/h	N	12390 / 7470	
		Drawbar pull laden/unladen, @ 4.8km/h	N	8950 / 7470	
Motor	5.7	Gradeability laden/unladen, @ 1.6km/h	%	31.0 / 29.0	
		Gradeability laden/unladen, @ 4.8km/h	%	21.6 / 29.0	
	5.10	Service brake		Hydraulic	
	7.1	Engine manufacturer/type		Yanmar 4TNE92	
	7.2	Engine output, in accordance with ISO1585	kW	29.1	
	7.3	Governed speed	rpm	2400	
	7.4	Number of cylinders/displacement	cm3	4 / 2659	
Other	8.1	Drive control		Hydrodynamic	
	8.2	Working pressure for attachments	bar	0 - 155	
	8.3	Oil flow for attachments ↓	l/min	69	
	8.4	Average noise level at operator's ear ★	dB(A)	80	
		Guaranteed sound power 2001/14/EC		104	
	8.5	Towing coupling type		Pin	

★ Measured according to the test cycles and based on the weighting values contained in EN12053.

↓ Variable

▲ Top of forks

✕ Full suspension seat in depressed position

▽ Add 32mm with load backrest

○ h6 subject to +/- 5mm tolerance

+ Without load backrest

Yale		Yale		1.1	Characteristics
GDP 18 VX		GDP 20 SVX		1.2	
Yanmar 2.6L Standard Electronic	Yanmar 2.6L Techtronix 100	Yanmar 2.6L Standard Electronic	Yanmar 2.6L Techtronix 100		
Base	Value	Base	Value		
Diesel	Diesel	Diesel	Diesel		1.3
Seat	Seat	Seat	Seat		1.4
1800	1800	2000	2000		1.5
500	500	500	500		1.6
384	384	384	384		1.8
1385	1385	1385	1385		1.9
3134	3134	3294	3294		2.1
4190 / 509	4190 / 509	4460 / 580	4460 / 580		2.2
1506 / 1628	1506 / 1628	1465 / 1829	1465 / 1829		2.3
SE	SE	SE	SE		3.1
6.50 X 10-10	6.50 X 10-10	6.50 X 10-10	6.50 X 10-10		3.2
5.00 X 8	5.00 X 8	18 X 7-8	18 X 7-8		3.3
2x/2	2x/2	2x/2	2x/2		3.5
890	890	890	890		3.6
895	895	895	895		3.7
6 / 5	6 / 5	6 / 5	6 / 5		4.1
2175	2175	2175	2175		4.2
100	100	100	100		4.3
3290	3290	3290	3290		4.4
3906	3906	3906	3906		4.5
2149	2149	2149	2149		4.7
1044	1044	1044	1044		4.8
321	321	321	321		4.12
3236	3236	3268	3268		4.19
2236	2236	2268	2268		4.20
1068	1068	1068	1068		4.21
40 X 80 X 1000	40 X 80 X 1000	40 X 100 X 1000	40 X 100 X 1000		4.22
IIA	IIA	IIA	IIA		4.23
977	977	977	977		4.24
110	110	110	110		4.31
146	146	146	146		4.32
3539	3539	3569	3569		4.33
3739	3739	3769	3769		4.34
1955	1955	1985	1985		4.35
48	48	48	48		4.36
20.5 / 20.9	20.5 / 20.9	20.5 / 20.9	20.5 / 20.9		5.1
0.63 / 0.72	0.63 / 0.72	0.62 / 0.72	0.62 / 0.72		5.2
0.51 / 0.47	0.51 / 0.47	0.51 / 0.47	0.51 / 0.47		5.3
14320 / 7200	14320 / 7200	14180 / 6930	14180 / 6930		5.5
12260 / 7200	12260 / 7200	12140 / 6930	12140 / 6930		
8860 / 7200	8860 / 7200	8770 / 6930	8770 / 6930		
28.2 / 26.3	28.2 / 26.3	25.4 / 23.6	25.4 / 23.6		5.7
20.0 / 26.3	20.0 / 26.3	17.9 / 23.6	17.9 / 23.6		
Hydraulic	Hydraulic	Hydraulic	Hydraulic		5.10
Yanmar 4TNE92	Yanmar 4TNE92	Yanmar 4TNE92	Yanmar 4TNE92		7.1
29.1	29.1	29.1	29.1		7.2
2400	2400	2400	2400		7.3
4 / 2659	4 / 2659	4 / 2659	4 / 2659		7.4
Hydrodynamic	Hydrodynamic	Hydrodynamic	Hydrodynamic		8.1
0 - 155	0 - 155	0 - 155	0 - 155		8.2
69	69	69	69		8.3
80	80	80	80		8.4
104	104	104	104		
Pin	Pin	Pin	Pin		8.5

Specification sheet truck based on:
3330mm tof 2 stage LFL mast with standard carriage,
1000mm forks and e-hydraulics.

VDI 2198 – General Specifications, LPG Powered GLP16VX, GLP18VX, GLP20SVX

		Yale		
		GLP 16 VX		
Characteristics	1.1	Manufacturer		
	1.2	Model designation		
		Power Train - Engine Transmission	Mazda 2.0L Standard Electronic	Mazda 2.0L Techtronix 100
		Model - Manufacturer Designation	Base	Value
	1.3	Power: battery, diesel, LPG, electric mains	LPG	LPG
	1.4	Operation: manual, pedestrian, stand, seat, order picker	Seat	Seat
	1.5	Load capacity	Q (kg)	1600
	1.6	Load centre	c (mm)	500
	1.8	Load distance	x (mm)	384
1.9	Wheelbase	y (mm)	1385	
Weights	2.1	Unladen weight	kg	3059
	2.2	Axle loading laden, front/rear	kg	3856 / 565
	2.3	Axle loading unladen, front/rear	kg	1521 / 1538
Wheels & Tyres	3.1	Tyres: L = Pneumatic, V = Cushion, SE = Supercushion		SE
	3.2	Tyre size-front		6.50 X 10-10
	3.3	Tyre size-rear		5.00 X 8
	3.5	Number of wheels, front/rear (X = driven)		2x/2
	3.6	Track width, front	b10 (mm)	890
	3.7	Track width, rear	b11 (mm)	895
	Dimensions	4.1	Mast tilt, forward α /back β	degrees
4.2		Height of mast, lowered	h1 (mm)	2175
4.3		Free lift ▲	h2 (mm)	100
4.4		Lift height ▲	h3 (mm)	3290
4.5		Height of mast, extended +	h4 (mm)	3906
4.7		Height to top of overhead guard ○	h6 (mm)	2149
4.8		Seat height ✕	h7 (mm)	1044
4.12		Towing coupling height	h10 (mm)	321
4.19		Overall length	l1 (mm)	3236
4.20		Length to face of forks	l2 (mm)	2236
4.21		Overall width	b1 (mm)	1068
4.22		Fork dimensions	s/e/l (mm)	40 X 80 X 1000
4.23		Fork carriage to DIN 15173. Class, A/B		IIA
4.24		Fork carriage width ▽	b3 (mm)	977
4.31		Ground clearance under mast, laden	m1 (mm)	110
4.32		Ground clearance at centre of wheelbase	m2 (mm)	146
4.33	Aisle width with pallets 1000mm x 1200mm wide	Ast (mm)	3539	
4.34	Aisle width with pallets 800mm x 1200mm long	Ast (mm)	3739	
4.35	Outer turning radius	Wa (mm)	1955	
4.36	Inner turning radius	b13 (mm)	48	
Performance	5.1	Travel speed laden/unladen	km/h	20.5 / 20.9
	5.2	Lifting speed laden/unladen	m/sec	0.57 / 0.58
	5.3	Lowering speed laden/unladen	m/sec	0.51 / 0.47
	5.5	Maximum drawbar pull laden/unladen,	N	13210 / 7470
		Drawbar pull laden/unladen, @ 1.6km/h	N	11330 / 7470
		Drawbar pull laden/unladen, @ 4.8km/h	N	8160 / 7470
	5.7	Gradeability laden/unladen, @ 1.6km/h	%	28.3 / 29.0
		Gradeability laden/unladen, @ 4.8km/h	%	20.0 / 29.0
5.10	Service brake		Hydraulic	
Motor	7.1	Engine manufacturer/type		Madza FE
	7.2	Engine output, in accordance with ISO1585	kW	29.8
	7.3	Governed speed	rpm	2400
	7.4	Number of cylinders/displacement	cm3	4 / 1998
Other	8.1	Drive control		Hydrodynamic
	8.2	Working pressure for attachments	bar	0 - 155
	8.3	Oil flow for attachments ↓	l/min	56
	8.4	Average noise level at operator's ear ★	dB(A)	78
		Guaranteed sound power 2001/14/EC		102
8.5	Towing coupling type		Pin	

★ Measured according to the test cycles and based on the weighting values contained in EN12053.

↓ Variable

▲ Top of forks

✕ Full suspension seat in depressed position

▽ Add 32mm with load backrest

○ h6 subject to +/- 5mm tolerance

+ Without load backrest

Yale		Yale		1.1	Characteristics
GLP 18 VX		GLP 20 SVX		1.2	
Mazda 2.0L Standard Electronic	Mazda 2.0L Techtronix 100	Mazda 2.0L Standard Electronic	Mazda 2.0L Techtronix 100		
Base	Value	Base	Value		
LPG	LPG	LPG	LPG		1.3
Seat	Seat	Seat	Seat		1.4
1800	1800	2000	2000		1.5
500	500	500	500		1.6
384	384	384	384		1.8
1385	1385	1385	1385		1.9
3134	3134	3294	3294		2.1
4190 / 509	4190 / 509	4460 / 580	4460 / 580		2.2
1506 / 1628	1506 / 1628	1465 / 1829	1465 / 1829		2.3
SE	SE	SE	SE		3.1
6.50 X 10-10	6.50 X 10-10	6.50 X 10-10	6.50 X 10-10		3.2
5.00 X 8	5.00 X 8	18 X 7-8	18 X 7-8		3.3
2x/2	2x/2	2x/2	2x/2		3.5
890	890	890	890		3.6
895	895	895	895		3.7
6 / 5	6 / 5	6 / 5	6 / 5		4.1
2175	2175	2175	2175		4.2
100	100	100	100		4.3
3290	3290	3290	3290		4.4
3906	3906	3906	3906		4.5
2149	2149	2149	2149		4.7
1044	1044	1044	1044		4.8
321	321	321	321		4.12
3236	3236	3268	3268		4.19
2236	2236	2268	2268		4.20
1068	1068	1068	1068		4.21
40 X 80 X 1000	40 X 80 X 1000	40 X 100 X 1000	40 X 100 X 1000		4.22
IIA	IIA	IIA	IIA		4.23
977	977	977	977		4.24
110	110	110	110		4.31
146	146	146	146		4.32
3539	3539	3569	3569		4.33
3739	3739	3769	3769		4.34
1955	1955	1985	1985		4.35
48	48	48	48		4.36
20.5 / 20.9	20.5 / 20.9	20.5 / 20.9	20.5 / 20.9		5.1
0.57 / 0.58	0.57 / 0.58	0.57 / 0.58	0.57 / 0.58		5.2
0.51 / 0.47	0.51 / 0.47	0.51 / 0.47	0.51 / 0.47		5.3
13070 / 7200	13070 / 7200	12920 / 6930	12920 / 6930		5.5
11190 / 7200	11190 / 7200	11050 / 6930	11050 / 6930		
8040 / 7200	8040 / 7200	7920 / 6930	7920 / 6930		
25.5 / 26.3	25.5 / 26.3	22.7 / 23.6	22.7 / 23.6		5.7
18.0 / 26.3	18.0 / 26.3	16.0 / 23.6	16.0 / 23.6		
Hydraulic	Hydraulic	Hydraulic	Hydraulic		5.10
Madza FE	Madza FE	Madza FE	Madza FE		7.1
29.8	29.8	29.8	29.8		7.2
2400	2400	2400	2400		7.3
4 / 1998	4 / 1998	4 / 1998	4 / 1998		7.4
Hydrodynamic	Hydrodynamic	Hydrodynamic	Hydrodynamic		8.1
0 - 155	0 - 155	0 - 155	0 - 155		8.2
56	56	56	56		8.3
78	78	78	78		8.4
102	102	102	102		
Pin	Pin	Pin	Pin		8.5

Specification sheet truck based on:
3330mm tof 2 stage LFL mast with standard carriage,
1000mm forks and e-hydraulics.

VX Series

Models: GDP/GLP 16VX, 18VX, 20SVX

Yale Veracitor VX Series

This series of trucks is available in two configurations.

The Veracitor Base truck offers first-rate performance for standard-duty applications and is geared to minimise cost of acquisition without compromising performance.

The Veracitor Value truck provides excellent performance for standard and medium-duty applications and is optimised for lowest hourly cost of operation.

Engines

Engines feature a rigid cast iron block and main bearing caps.

Hydraulic valve lifters eliminate the need for manual adjustment. All engines include hardened exhaust valve seats. All engines are Tier 2 emissions compliant and feature closed loop emissions regulation systems that continually monitor exhaust and adjust fuel/air mix.

Fuel System

The Mazda LPG engine uses a single barrel non adjustable carburetor with an LPG injector and a regulator/vaporizer. The Engine Control Unit controls the LPG injector fueling. The Yanmar fuel system has an Electro-mechanical controlled throttle providing excellent response time. Super quick glow plugs allow the engine to start quickly and reliably under cold conditions, the cold start device delivers a cleaner exhaust under cold conditions by advancing the fuel injection timing based on water temperature. Emissions have been reduced by controlling fuel injection timing according to engine load.

Transmission

Two transmission selections are available with engine configurations that will fulfill a wide variety of material handling applications.

1) Standard Electronic features electronic inching, electric shift control, neutral start switch, and anti-restart protection and heavy duty clutch packs.

A single pedal controls both inching and braking.

Optional dual inch/brake pedals are available for operators who prefer this design. A 100 mesh suction and a 10 micron return line filtration protect the

transmission from abrasive contaminants.

2) The Techtronix 100 has all the Standard Electronic features plus Auto Deceleration System through the controlled application of clutch packs, reduces tyre spin by precisely regulating engine speed during controlled power reversals.

Cooling System

The cooling system employs a 43cm blade pusher-type fan. A permanently lubricated water pump and a high capacity, cross-flow radiator ensure rapid heat dissipation. The sealed cooling system operates at 15 psi, the coolant recovery tank allows visual inspection of coolant level. A transmission oil cooler is integrated into the radiator and is located in the side tank. The optional combicooler radiator features an externally mounted transmission oil cooler for increased heat transfer capability. All radiators are softmounted for durability.

Drive Axle

The drive axle is designed to withstand heavy-duty applications and absorb shock loads. It is a "self contained" assembly isolated from the transmission by a heavy-duty rubber isolator. The axle shafts utilize a "rolled fillet" root spline design for increased resistance to torsion stress. A magnetic sump plug collects any metal particles circulating in the axle oil to prevent component wear.

Brakes

Brakes are duo-servo hydraulic, self-energizing, and automatic adjusting drum brake assemblies. Asbestos-free brake linings are bonded to steel shoes and act against a cast iron drum. Single circuit master cylinder has sealed fluid reservoir and features a fluid level sensor which activates an indicator light located on the instrument panel.

Hydraulic Power Steering

Hydrostatic steering provides responsive control and eliminates mechanical linkages for reduced surface shock and simplified maintenance. The steering wheel is 30cm in diameter with a textured surface grip and spinner knob, and requires only four turns lock-to-lock. The centre mounted steer cylinder is located within the confines of the steer axle for protection.

Steer Axle

Constructed from cast steel, the steer axle is rubber shock mounted to the frame for reduced wear and vibration. The CSE (Continuous Stability Enhancement) system enhances lateral truck stability through reduced steer axle articulation, while simultaneously allowing uncompromised uneven surface travel.

Operator's Compartment

Base truck features cowl mounted hydraulic control levers positioned on the right side of the steering column. Value trucks feature Accutouch or PalmTech electrohydraulic controls integrated into the operator's right-side armrest for superior ergonomic actuation.

Automotive-style pedal arrangement with a large, single inch/brake pedal is standard.

Intellix Vehicle System Management (VSM)

VSM acts as a master truck controller, providing extensive monitoring and control of truck functions and systems. CANbus technology reduces wiring complexity and enables communications between truck systems. The ergonomically positioned dash display transmits continual feedback to the operator and allows communication of service codes. On-board diagnostics enable quick and easy troubleshooting. The electrical system features sealed connectors and Hall Effect sensors for superior dependability.

Hydraulic System

Hydraulic system incorporates a gear type pump with cast iron body for quiet efficiency. System is protected from overloads by a main relief valve for the lift circuit and secondary relief valve for tilt and auxiliary functions. Oil is double filtered through a 100 mesh suction line strainer and 10 micron return line filter. Hydraulic tank is integrated into the frame.

For Accutouch or PalmTech joystick electrohydraulic controls, an emergency lowering valve is provided to allow the load to be lowered in the event of power loss. O-ring face seal fittings are used in all high pressure hydraulic connections.



NACCO Materials Handling Limited trading as Yale Europe Materials Handling
Flagship House, Reading Road North, Fleet, Hampshire GU51 4WD, United Kingdom.
Tel: + 44 (0) 1252 770700 Fax: + 44 (0) 1252 770784
www.yale-forklifts.eu

Country of Registration: England. Company Registration Number: 02636775



Safety. This truck conforms to the current EU requirements. Specification is subject to change without notice.

Publication part no. 290000126 Rev.07(07)
Printed in The United Kingdom (021110HG) EN

Yale is a registered trade mark.
© Yale Europe Materials Handling 2011. All rights reserved.

Truck shown with optional equipment