

Electric forklift truck

Electric forklift truck 4-wheel front traction, AC technology and DC lifting motor, full-free-view mast lifting from 3.300 to 6.000 mm, integrated side-shift, power steering, steering column multiple adjustable, LCD display with 3 different power output possibilities E (Economy) S (Super) P (Power) Characterized by its handiness and compact dimensions, it is suitable for all commodity uses.

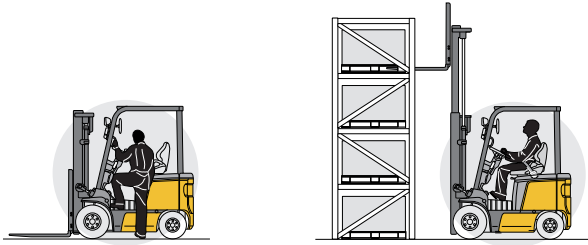

we make ideas alive

OMG S.p.A.
via dell'Artigianato, 12
46023 - GONZAGA (MN) Italy
Tel. + 39 0376 52.60.11
Fax. + 39 0376 58.80.08
www.omgindustry.com
info@omgindustry.com



Azienda Certificata
ISO 9001:2008 N°7236 MN
ISO 9001:2008 N°23355

• Ergos III 18 TA4 ac

Characteristics	1.1 Manufacturer			OMG S.p.A.
	1.2 Manufacturer's model designation			ERGOS III 18 TA4 AC
Weights	1.3 Drive : E (electric)			E
	1.4 Type of control : S (steering wheel) R (seated)			S / R
Wheels - Chassis	1.5 Load capacity			Q (t)
	1.6 Load centre distance			c (mm)
Dimensions	1.8 Load distance, centre of drive axle to fork			X (mm)
	1.9 Wheelbase			Y (mm)
Performances	2.1 Service weight (battery included)			Kg
	2.2 Axle loading (with load)			front / rear
E.I. Motor	2.3 Axle loading (without load)			front / rear
	3.1 Tyres : se (superelastic)			se
Others	3.2 Front wheels size			mm
	3.3 Rear wheels size			mm
Others	3.5 Wheels : number front / rear (x = traction)			2 x / 2
	3.6 Track width, front			b 10 (mm)
Others	3.7 Track width, rear			b 11 (mm)
	4.1 Mast tilting forward / backward			a / b
Others	4.2 Lowered mast height			h1 (mm)
	4.3 Free lift			h5 (mm)
Others	4.4 Lifting height			h3 (mm)
	4.5 Extended mast height			h4 (mm)
Others	4.6 Free lift			h2 (mm)
	4.7 Overhead guard (cab)			h6 (mm)
Others	4.8 Seat height			h7 (mm)
	4.12 Coupling height			h10 (mm)
Others	4.19 Total length			l1 (mm)
	4.20 Length to forks face			l2 (mm)
Others	4.21 Overall width			b1 / b2 (mm)
	4.22 Forks dimensions			s / e / l
Others	4.23 Fork carriage Class / Type A, B			II A
	4.24 Fork carriage width			b3 (mm)
Others	4.31 Ground clearance, under the mast			laden
	4.32 Ground clearance, centre of wheelbase			laden
Others	4.33 Aisle width with pallets 1000 x 1200 forking side 1200			Ast3 (mm)
	4.34 Aisle width with pallets 800 x 1200 forking side 800			Ast3 (mm)
Others	4.35 Turning radius			Wa (mm)
	4.36 Smallest pivot point distance			b13 (mm)
Others	5.1 Travel speed			laden / unladen
	5.2 Lifting speed			laden / unladen
Others	5.3 Lowering speed			laden / unladen
	5.5 Drawbar pull			N
Others	5.6 Max drawbar pull			N
	5.7 Gradient performance			%
Others	5.8 Max gradient performance			%
	5.9 Acceleration time (10 m)			s
Others	5.10 Service brake M (mechanical) I (hydraulic) IV (inversion braking)			M / I
	6.1 Traction motor, rating S2 60 min			KW
Others	6.2 Lifting motor, rating S3 15%			KW
	6.3 Battery according DIN 43531 / 35 / 36 A, B, C, no			no
Others	6.4 Battery voltage, nominal capacity K5			V / Ah
	6.5 Battery weight (± 5 %)			Kg
Others	6.6 Battery consumption according VDI cycle			KWh / h
	8.1 Type of travel control			AC
Others	8.2 Operating pressure for attachments			bar
	8.3 Oil volume for attachments (max available)			l / min
Others	8.4 Sound level at driver's ear			dB (A)
	8.5 Tow coupling, type DIN			

servo-steering	s	extra hydraulic function	o
adjustable steering column	s	backwards light	s
LCD display	s	working lights	s
BDI/hour meter with lifting cut-off at 80% discharge	s	complete cabin	o
traction speed visualization	s	half cabin	o
3 different power output possibilities	s	no marking tyres	o
wide visibility mast	s	cold store execution	o
side-shift	s	heating system	o
s=standard		o=option	

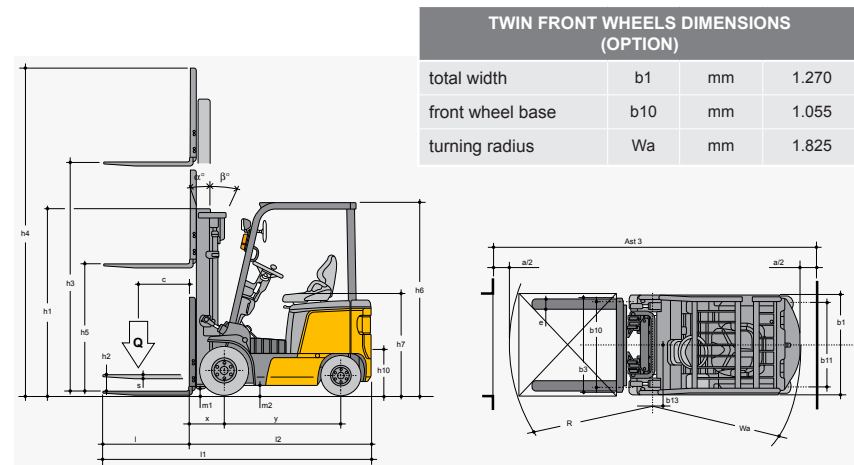

h3		h1	h4	h4 (1)	h2	h5	h5 (1)	(Q) t
2.965 dx	mm	1.995	3.560	4.030	155	1.460	990	1.75
3.265 dx	mm	2.145	3.860	4.330	155	1.610	1.140	1.75
3.465 dx	mm	2.245	4.060	4.530	155	1.710	1.240	1.75
3.665 dx	mm	2.345	4.260	4.730	155	1.810	1.340	1.75
3.965 dx	mm	2.545	4.560	5.030	155	2.010	1.540	1.65 / 1.75*
4.465 dx	mm	2.795	5.060	5.530	155	2.260	1.790	1.5 / 1.65*
4.965 dx	mm	3.045	5.560	6.030	155	2.510	2.040	1.0 / 1.5*
4.315 tx ffl	mm	1.995	4.910	5.380	/	1.460	990	1.55 / 1.6*
4.765 tx ffl	mm	2.145	5.360	5.830	/	1.610	1.140	1.4 / 1.55*
4.965 tx ffl	mm	2.245	5.560	6.030	/	1.710	1.240	1.15 / 1.5*
5.465 tx ffl	mm	2.410	6.060	6.530	/	1.875	1.405	0.85 / 1.35*
5.965 tx ffl	mm	2.595	6.560	7.030	/	2.060	1.590	0.55 / 1.25*

(1) with load guard protection 470 mm / * twin front wheels

Technical specification according VDI 2198

Information and data are given for information only, OMG S.p.A. will have the sole right for technical changes and improvements without giving any notice.