

# MODEL RANGE

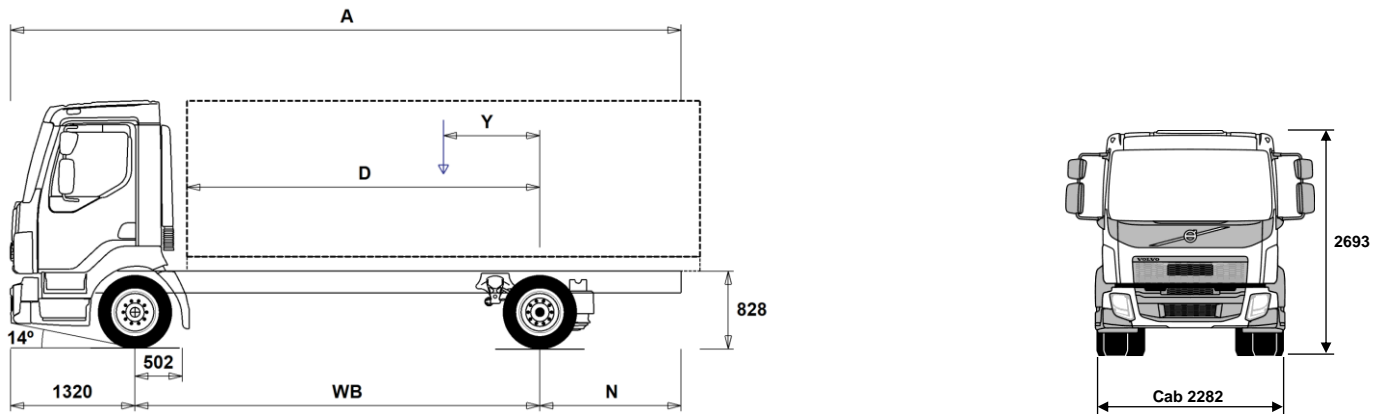

Volvo Trucks. Driving Progress

FL512 4x2 Platform 12 tonne - Rear Air Suspension FL 42 R 512A



## Chassis Dimensions [mm]

WB Wheelbase	3500	3800	4100	4400	4700	5000	5300	5600	5900	6200	6500
A Overall Chassis Length	6975	7425	7955	8425	8915	9615	9915	10425	10835	11430	11730
D Center of rear axle to front of body	2948	3248	3548	3848	4148	4448	4748	5048	5348	5648	5948
N Rear Overhang (Min.)	2055	1885	2445	2635	2835	2895	2895	3415	3295	3505	3755
N Rear Overhang (Max.)	2155	2305	2535	2705	2895	3295	3295	3505	3615	3910	3910
Y Center of Gravity for Payload (Min.)	275	299	323	346	369	391	410	432	462	477	494
Y Center of Gravity for Payload (Max.)	705	767	830	891	952	1016	1073	1134	1201	1259	1316

## Chassis Weights [kg]

Front Axle	2895	2895	2895	2895	2900	2905	2915	2920	2910	2925	2930
Rear Axle	1135	1150	1170	1185	1210	1250	1255	1275	1275	1315	1320
Kerb Weight	4030	4045	4065	4080	4110	4155	4170	4195	4185	4240	4250
Payload (including body, driver, fuel, etc.)	7970	7955	7935	7920	7890	7845	7830	7805	7815	7760	7750

## Turning Diameter [mm]

Turning Circle Diameter Kerb to Kerb	12400	13300	14200	15000	15900	16800	17700	18600	19500	20400	21300
Turning Circle Diameter Wall to Wall	13700	14600	15500	16400	17300	18200	19100	20000	20900	21800	22700

## Plated Weights [kg]

	Plated	Design
Gross Vehicle Weight	12000	12000
Gross Combination Weight	15500	15500
Front Axle	4500	4500
Rear Axle	8480	8500

## Important Notes

### Chassis Dimensions

Cab Height: +39 mm for CAB-CRW.  
 Front Axle to Back of Cab: +1338 mm for CAB-CRW, +330 mm for CAB-SSLP.  
 D-measure includes a front clearance of 50 mm and for rigid trucks also a subframe of 120 mm.  
 Height can vary  $\pm 20$  mm for leaf and  $\pm 10$  mm for air suspension.  
 All dimensions are for unladen chassis and any tag axles down. Chassis height used: CHH-LOW.

Weight and dimensions are based upon the following tyres:

Front Axle Tyres: 245/70R17.5  
 Drive Axle Tyres: 245/70R17.5

Chassis weight includes oil, water, AdBlue, 0 litres fuel and without driver. Kerb weight can vary  $\pm 3\%$ .

Turning diameters are theoretically calculated.

Legal weights can differ from country to country.

For more detailed weight information, including optional equipment weights, ask your Volvo sales contact to enter your specification into the Volvo Weight Information system (WIS).

Do NOT use this drawing for bodybuilding. Refer to Volvo Bodybuilder Instructions and chassis assembly drawing FL42R512A.

# MODEL RANGE

FL512 4x2 Platform 12 tonne - Rear Air Suspension FL 42 R 512A

## CORE COMPONENTS

- **CHH-LOW** Chassis height low - For a specific loading height always check the unique BEP chassis drawing
- **CHH-MED** Chassis height medium - For a specific loading height always check the unique BEP chassis drawing
- **RAD-A2V** Two bag rear air suspension
- **EU6SCR** Emission level - Euro 6
- **D5K210** D5K210 four cylinder 5.1 litre engine developing 210hp at 2200rpm.  
Peak torque 800Nm at 1100-1700rpm.
- **D5K240** D5K240 four cylinder 5.1 litre engine developing 240hp at 2200rpm.  
Peak torque 900Nm at 1100-1600rpm.
- **EBR-EPG** Exhaust brake producing 120kW at 2800rpm controlled by steering column switch
- **ATO1056** 6-speed overdrive "I Sync" automated mechanical gearbox
- **ATO8006** 6-speed overdrive "I Sync" automated mechanical gearbox
- **STO8006** 6 speed overdrive gearbox, 850 Nm
- **ZTO1006** 6-speed overdrive gearbox
- **RSS0819A** RSS0819A single reduction rear axle - design GCW 18.7 tonne with differential lock
- **RSS1125A** RS1125A single reduction rear axle - design GCW 25tonne with differential lock
- **RSS1132A** RS1132A single reduction rear axle - design GCW 32tonne with differential lock

## Packages

- **DRIVEFL** NEW drive package FL
- **VISIFL** NEW visibility package FL
- **AIRFLOW** NEW airflow package
- **AUDIOBAS** AM/FM Radio with Bluetooth and optional DAB signal - without CD player
- **AUDIOPK** Audio preparation

## CHASSIS

- **FST-PAR** Parabolic front springs with shock absorbers and anti roll bar
- **FAL4.5** Front axle design capacity 4.5 tonnes
- **FAL5.0** Front axle design capacity 5.0 tonnes
- **RAL10.6** Rear axle design capacity 10.6 tonnes
- **RAL10.9** Rear axle design capacity 10.9 tonnes
- **RAL8.5** Rear axle design capacity 8.5 tonnes
- **RAL9.2** Rear axle design capacity 9.2 tonnes
- **RAL9.5** Rear axle design capacity 9.5 tonnes
- **EBS-MED** EBS+ package including traction control & hill hold
- **EBS-STD** EBS standard package without traction control
- **RST-AIR** Rear air suspension
- **SUSPL-E1** Remote control on wander-lead for air suspension leveling
- **SUSPL-E3** Remote control on wander-lead for air suspension leveling
- **FST6060** Frame thickness 6mm
- **FST7070** Frame thickness 7mm
- **FST8080** Frame thickness 8mm
- **2BATT170** 2 x 170 Ah capacity batteries on left hand side
- **BAMAFREE** Maintenance free batteries
- **ADR2** ADR package for transportation of dangerous goods on road (Note does NOT include safe loading pass package if required this is quoted separately)
- **R215P** 215 litre right hand plastic fuel tank  
Min volume 80l  
Max volume 430l
- **UL-FUEL** Without left fuel tank
- **ADTP-R** AdBlue tank on right hand side
- **WHC-FIX1** One wheel chock

- **WHC-FIX2** Two wheel chocks
- **TOWMBRH** Towing member, high position, mounted in centre of frame
- **C-RO40AG** Rockinger 400 G145
- **TOWF-NO1** One towing device in front.
- **TOWF-NO2** Two towing devices in front.
- **TOWR-ONE** Pintle type towing hitch attached to rear crossmember for 3.5tonne trailer
- **TREL15** Single 15 pole electrical trailer connector - ADR certified
- **TBC-EC**
- **RUP-FIX2** Fixed rear EC approved aluminium underrun
- **RFEND-T** Mudwings on drive axle for transportation only

## WHEELS & TYRES

- **SPWT-F** Spare wheel & tyre with front tyre pattern
- **SWCP-LF** Spare wheel carrier on left side of chassis ahead of rear axle
- **SWCP-R** Spare wheel carrier rear mounted below frame.
- **SWCP-T** Spare wheel supplied temporarily strapped to chassis
- **SWCP-TP** Spare wheel carrier transport mounted on frame (spare wheel carrier not included)
- **JACK-6T**
- **JACK-8T** 8 tonne bottle jack
- **GAUGE-TP** Tyre pressure gauge

## DRIVELINE EQUIPMENT

- **CS39A-O** Single plate 395mm (16") clutch
- **1COMP500** Single cylinder air compressor 360 cc / 500 l/min
- **AIRIN-FR** Front air intake
- **AIRIN-HI** High air intake behind cab on left hand side
- **AIRIN-RL** Chassis mounted mounted behind cab on right hand side
- **ACL1ST** Air cleaner with one filter element
- **ACL1ST-S** Air filter with secondary filter element
- **24AL110B** 110 amp alternator
- **24AL130B** 130 amp alternator
- **CCV-C** Closed crankcase ventilation
- **CCV-OX** Open crankcase ventilation with oil separator and a maintenance free gas centrifuge
- **EST-AID** Air inlet manifold starting heater element
- **PTER-100** Rear engine mounted power-take-off with DIN 7476 flange
- **PTER-DIN** Rear engine mounted PTO with DIN5462 (female) splined shaft for a close coupled pump
- **PTER1400** Rear engine mounted power-take-off with SAE 1410 flange
- **PTR-FH5** Rear PTO Gearbox S88 flange DIN connection
- **PTR-PH4** Rear PTO Gearbox S88 pump DIN connection
- **HPG-F101** Gearbox mounted hydraulic pump F1-101, fixed displacement, single flow.
- **HPG-F41** Gearbox mounted hydraulic pump F1-41, fixed displacement, single flow.
- **HPG-F51** Gearbox mounted hydraulic pump F1-51, fixed displacement, single flow.
- **HPG-F61** Gearbox mounted hydraulic pump F1-61, fixed displacement, single flow.
- **HPG-F81** Gearbox mounted hydraulic pump F1-81, fixed displacement, single flow.
- **ETC** Electronic throttle control - dash mounted switch for PTO speed control

## CAB INTERIOR

- **STWPOS-R** RIGHT HAND DRIVE

## CAB EXTERIOR

- **SUNV-B** Exterior sun visor - smoked grey
- **SUNV-PK** Sunvisor installation preparation kit

- Standard Equipment
- Optional Equipment

For more detailed information about cab and powertrain equipment, please refer to separate specification sheets.

For all possible options and combinations of options please consult your Volvo sales contact who can create a specification to match your requirements using the Volvo Sales Support system (VSS).

The factory reserves the right to modify design and change equipment without previous notification. The specification can vary from country to country.

# MODEL RANGE

FL512 4x2 Platform 12 tonne - Rear Air Suspension FL 42 R 512A

---

- **AD-ROOF** Fixed cab roof air deflector - not adjustable
- **AD-SIDES** Cab side air deflector, short extension panels.
- **BEACON-P** Beacon preparation
- **BEACONA2** Two amber beacons directly mounted to cab roof

## **SUPERSTRUCTURE PREPARATIONS**

- **FBA-BTF** Lower front body attachments for torsionally flexible - platform body
- **FBA-BTSF** Lower front body attachments for torsionally semi-flexible body - box or curtainsider
- **RBA-T2** Rear body attachments, divided
- **TAILPREP** Taillift preparation kit - cab switch and warning in driver display

## **DELIVERY SERVICES**

- **WVTA** Whole Vehicle Type Approved - MANDATORY for standard truck

**VOLVO**

Volvo Truck Corporation  
volvotrucks.com