

MODEL RANGE

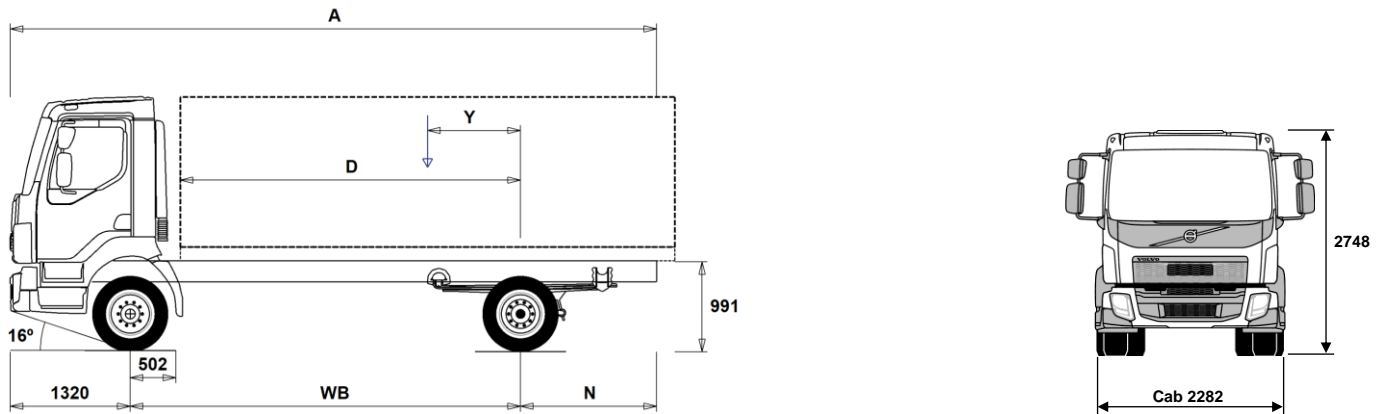

Volvo Trucks. Driving Progress

FL514 4x2 Rigid 14 tonne - Steel Suspension FL 42 R 514L



Chassis Dimensions [mm]

WB Wheelbase	3250	3500	3800	4100	4400	4700	5000	5300	5600	5900	6200	6500
A Overall Chassis Length	6545	6975	7425	7955	8425	8915	9435	9915	10425	10835	11430	11730
D Center of rear axle to front of body	2698	2948	3248	3548	3848	4148	4448	4748	5048	5348	5648	5948
N Rear Overhang (Min.)	1885	2055	1855	2445	2635	2835	2895	2895	3415	3295	3505	3755
N Rear Overhang (Max.)	1975	2155	2305	2535	2705	2895	3115	3295	3505	3615	3910	3710
Y Center of Gravity for Payload (Min.)	516	560	612	667	721	772	824	877	931	977	1033	1080
Y Center of Gravity for Payload (Max.)	516	560	612	667	721	772	824	877	931	977	1033	1080

Chassis Weights [kg]

Front Axle	3070	3065	3055	3045	3040	3040	3040	3040	3035	3045	3045	3050
Rear Axle	1235	1275	1310	1340	1365	1390	1425	1450	1470	1500	1530	1540
Kerb Weight	4305	4340	4365	4385	4405	4430	4465	4490	4505	4545	4575	4590
Payload (including body, driver, fuel, etc.)	8895	8860	8835	8815	8795	8770	8735	8710	8695	8655	8625	8610

Turning Diameter [mm]

Turning Circle Diameter Kerb to Kerb	11600	12400	13300	14200	15100	16000	16900	17700	18600	19500	20400	21300
Turning Circle Diameter Wall to Wall	12900	13700	14600	15500	16400	17300	18200	19100	20000	20900	21800	22700

Plated Weights [kg]

	Plated	Design
Gross Vehicle Weight	13200	14000
Gross Combination Weight	19500	19500
Front Axle	4480	5000
Rear Axle	8720	9500

Important Notes

Chassis Dimensions

Cab Height: +39 mm for CAB-CRW.
 Front Axle to Back of Cab: +1338 mm for CAB-CRW, +330 mm for CAB-SSLP.
 D-measure includes a front clearance of 50 mm and for rigid trucks also a subframe of 120 mm.
 Height can vary ± 20 mm for leaf and ± 10 mm for air suspension.
 All dimensions are for unladen chassis and any tag axles down. Chassis height used: CHH-MED.

Weight and dimensions are based upon the following tyres:
 Front Axle Tyres: 245/70R19.5
 Drive Axle Tyres: 245/70R19.5

Chassis weight includes oil, water, AdBlue, 0 litres fuel and without driver. Kerb weight can vary $\pm 3\%$.

Turning diameters are theoretically calculated.

Legal weights can differ from country to country.

For more detailed weight information, including optional equipment weights, ask your Volvo sales contact to enter your specification into the Volvo Weight Information system (WIS).

Do NOT use this drawing for bodybuilding. Refer to Volvo Bodybuilder Instructions and chassis assembly drawing FL42R514L.

MODEL RANGE

FL514 4x2 Rigid 14 tonne - Steel Suspension FL 42 R 514L

CORE COMPONENTS

- CHH-HIGH** Chassis height high - N3 "On Road" chassis - For a specific loading height always check the unique BEP chassis drawing
- CHH-MED** Chassis height medium - For a specific loading height always check the unique BEP chassis drawing
- RAD-L80** 80mm parabolic rear springs
- EU6SCR** Emission level - Euro 6
- D5K210** D5K210 four cylinder 5.1 litre engine developing 210hp at 2200rpm.
Peak torque 800Nm at 1100-1700rpm.
- D5K240** D5K240 four cylinder 5.1 litre engine developing 240hp at 2200rpm.
Peak torque 900Nm at 1100-1600rpm.
- EBR-EPG** Exhaust brake producing 120kW at 2800rpm controlled by steering column switch
- ATO1056** 6-speed overdrive "I Sync" automated mechanical gearbox
- ATO8006** 6-speed overdrive "I Sync" automated mechanical gearbox
- STO8006** 6 speed overdrive gearbox, 850 Nm
- ZTO1006** 6-speed overdrive gearbox
- RSS1125A** RS1125A single reduction rear axle - design GCW 25tonne with differential lock
- RSS1132A** RS1132A single reduction rear axle - design GCW 32tonne with differential lock

Packages

- DRIVEFL** NEW drive package FL
- VISIFL** NEW visibility package FL
- AIRFLOW** NEW airflow package
- AUDIOBAS** AM/FM Radio with Bluetooth and optional DAB signal - without CD player
- AUDIOPK** Audio preparation

CHASSIS

- FST-PAR** Parabolic front springs with shock absorbers and anti roll bar
- FST-PAR3** Stiff parabolic front springs with shock absorbers and anti roll bar
- FAL5.0** Front axle design capacity 5.0 tonnes
- FAL5.6** Front axle design capacity 5.6 tonnes
- FAL5.8** Front axle design capacity 5.8 tonnes
- RAL10.6** Rear axle design capacity 10.6 tonnes
- RAL9.5** Rear axle design capacity 9.5 tonnes
- RSTAB1** Rear anti-roll bar
- EBS-MED** EBS+ package including traction control & hill hold
- EBS-STD** EBS standard package without traction control
- RST-PAR1** Parabolic rear springs
- RST-PAR3** Stiffer parabolic rear springs
- FST6060** Frame thickness 6mm
- FST7070** Frame thickness 7mm
- FST8080** Frame thickness 8mm
- 2BATT170** 2 x 170 Ah capacity batteries on left hand side
- BAMAFREE** Maintenance free batteries
- ADR2** ADR package for transportation of dangerous goods on road (Note does NOT include safe loading pass package if required this is quoted separately)
- R215P** 215 litre right hand plastic fuel tank
Min volume 80l
Max volume 430l
- UL-FUEL** Without left fuel tank
Min volume 80l
Max volume 215l
- ADTP-L** AdBlue tank on left hand side
- ADTP-R** AdBlue tank on right hand side

Standard Equipment Optional Equipment

For more detailed information about cab and powertrain equipment, please refer to separate specification sheets.

For all possible options and combinations of options please consult your Volvo sales contact who can create a specification to match your requirements using the Volvo Sales Support system (VSS).

The factory reserves the right to modify design and change equipment without previous notification. The specification can vary from country to country.

- WHC-FIX1** One wheel chock
- WHC-FIX2** Two wheel chocks
- TOWMBRH** Towing member, high position, mounted in centre of frame
- C-RO40AG** Rockinger 400 G145
- TOWF-NO1** One towing device in front.
- TOWF-NO2** Two towing devices in front.
- TOWR-ONE** Pintle type towing hitch attached to rear crossmember for 3.5tonne trailer
- TREL15** Single 15 pole electrical trailer connector - ADR certified
- TBC-EC**
- RUP-FIX2** Fixed rear EC approved aluminium underrun
- RFEND-T** Mudwings on drive axle for transportation only

WHEELS & TYRES

- SPWT-F** Spare wheel & tyre with front tyre pattern
- SWCP-LF** Spare wheel carrier on left side of chassis ahead of rear axle
- SWCP-R** Spare wheel carrier rear mounted below frame.
- SWCP-T** Spare wheel supplied temporarily strapped to chassis
- SWCP-TP** Spare wheel carrier transport mounted on frame (spare wheel carrier not included)
- JACK-10T** 10 tonne bottle jack
- JACK-8T** 8 tonne bottle jack
- GAUGE-TP** Tyre pressure gauge

DRIVELINE EQUIPMENT

- CS39A-O** Single plate 395mm (16") clutch
- RET-TPT** Retarder for automatic gearbox
- TC-HWO** Automatic gearbox oil cooler - water to oil
- 1COMP500** Single cylinder air compressor 360 cc / 500 l/min
- AIRIN-FR** Front air intake
- AIRIN-HI** High air intake behind cab on left hand side
- AIRIN-RL** Chassis mounted mounted behind cab on right hand side
- ACL1ST** Air cleaner with one filter element
- ACL1ST-S** Air filter with secondary filter element
- 24AL110B** 110 amp alternator
- 24AL130B** 130 amp alternator
- CCV-C** Closed crankcase ventilation
- CCV-OX** Open crankcase ventilation with oil separator and a maintenance free gas centrifuge
- EST-AID** Air inlet manifold starting heater element
- PTER-100** Rear engine mounted power-take-off with DIN 7476 flange
- PTER-DIN** Rear engine mounted PTO with DIN5462 (female) splined shaft for a close coupled pump
- PTER1400** Rear engine mounted power-take-off with SAE 1410 flange
- PR-HF4S** Live-drive PTO for Allison gearbox output 400Nm for flange connection
mounted on the side of the torque convertor
- PR-HF4SH** Live-drive high speed PTO for Allison gearbox output 400Nm for hydraulic pump connection
mounted on the side of the torque convertor
- PR-HF6S** Live-drive PTO for Allison gearbox output 600Nm for flange connection
mounted on the side of the torque convertor
- PR-HP4S** Live-drive PTO for Allison gearbox output 400Nm for hydraulic pump connection
mounted on the side of the torque convertor
- PR-HP4SH** Live-drive high speed PTO for Allison gearbox output 400Nm for hydraulic pump connection
mounted on the side of the torque convertor
- PR-HP6S** Live-drive PTO for Allison gearbox output 600Nm for hydraulic pump connection
mounted on the side of the torque convertor
- PTR-FH1** Rear PTO Gearbox S81 flange DIN connection

MODEL RANGE

FL514 4x2 Rigid 14 tonne - Steel Suspension FL 42 R 514L

- PTR-FH2** Rear PTO Gearbox S84 flange DIN connection
- PTR-FH5** Rear PTO Gearbox S88 flange DIN connection
- PTR-PH1** Rear PTO Gearbox S81 pump DIN connection
- PTR-PH2** Rear PTO Gearbox S84 pump DIN connection
- PTR-PH4** Rear PTO Gearbox S88 pump DIN connection
- PTR-PK** Electrical and solenoid prep kit for gearbox PTO
- PTR-ZF2** Rear Power Take Off flange DIN connection
- PTR-ZF3** Rear Power Take Off Gearbox pump DIN connection
- PTR-ZF4** Rear PTO Gearbox 320Nm flange connection
- PTR-ZF5** Rear PTO Gearbox 320Nm pump connection
- PTR-ZF6** Rear PTO Gearbox 320Nm flange connection

- HPG-F101** Gearbox mounted hydraulic pump F1-101, fixed displacement, single flow.
- HPG-F41** Gearbox mounted hydraulic pump F1-41, fixed displacement, single flow.
- HPG-F51** Gearbox mounted hydraulic pump F1-51, fixed displacement, single flow.
- HPG-F61** Gearbox mounted hydraulic pump F1-61, fixed displacement, single flow.
- HPG-F81** Gearbox mounted hydraulic pump F1-81, fixed displacement, single flow.

- ETC** Electronic throttle control - dash mounted switch for PTO speed control

CAB INTERIOR

- **STWPOS-R** RIGHT HAND DRIVE

CAB EXTERIOR

- SUNV-B** Exterior sun visor - smoked grey
- **SUNV-PK** Sunvisor installation preparation kit
- AD-ROOF** Fixed cab roof air deflector - not adjustable
- AD-SIDES** Cab side air deflector, short extension panels.
- BEACON-P** Beacon preparation
- BEACONA2** Two amber beacons directly mounted to cab roof

SUPERSTRUCTURE PREPARATIONS

- FBA-BTF** Lower front body attachments for torsionally flexible - platform body
- FBA-BTSF** Lower front body attachments for torsionally semi-flexible body - box or curtainsider
- RBA-T2** Rear body attachments, divided
- TAILPREP** Taillift preparation kit - cab switch and warning in driver display

DELIVERY SERVICES

- **WVTA** Whole Vehicle Type Approved - MANDATORY for standard truck

VOLVO

Volvo Truck Corporation

volvotrucks.com