

MOVING YOU **FURTHER**

# HL940A TM

With Tier4 final / Stage V Engine installed



\*Photo may include optional equipment.

**Net Power**

154 HP (115kW) at 2,200 rpm

**Gross Power**

156 HP (116kW) at 2,200 rpm

**Bucket Capacity**

2.3 m<sup>3</sup> (3.0yd<sup>3</sup>)

**Operating Weight**

13,800kg (30,420lb)

# HL940A™

## FUEL EFFICIENT SYSTEM ALLOWS GREAT PERFORMANCE

HL A Series has an eco-friendly, high-performance engine which ensures both excellent fuel efficiency and high power.

With outstanding operating performance proven by rigorous tests at various work sites, it will satisfy any customer's needs.



\*Photo may include optional equipment.

## SPECIFICATIONS & DIMENSIONS

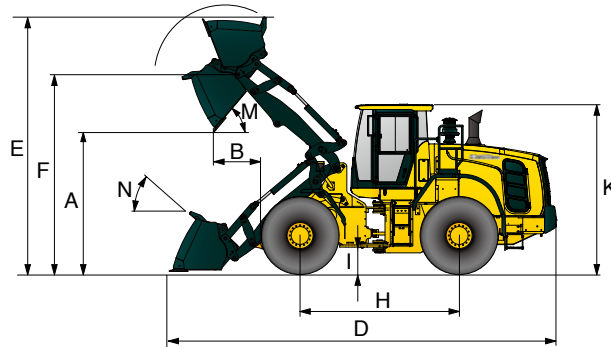
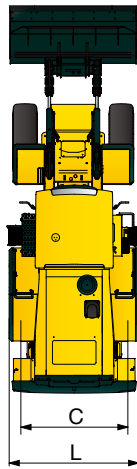

### Specifications

ITEM	HL940A™	
Type	-	Hydraulic type
Engine	Maker / Model	CUMMINS / B6.7
	Gross power	HP(kW)/rpm 156(116) / 2,200
	Net power	HP(kW)/rpm 154(115) / 2,200
	Peak gross torque	Kgf · m(lb · ft)/rpm 76 (550) / 1,300
	No. of cylinders	ea 6
Operating weight	kg (lb)	13,800 (30,420)
Bucket capacity	Heaped	m <sup>3</sup> (yd <sup>3</sup> ) 2.3 (3.0)
	Struck	m <sup>3</sup> (yd <sup>3</sup> ) 2.0 (2.6)
Breakout force-bucket	kg (lb)	10,830 (23,880)
Tipping load	Straight	kg (lb) 8,880 (19,580)
	Full turn	kg (lb) 7,640 (16,840)

\* Engine Type: 4-cycle, water cooled, turbocharged, diesel, direct injection

### Dimensions

UNIT	HL940A™
A mm (ft-in)	2,840 (9' 4")
B mm (ft-in)	1,380 (4' 6")
C mm (ft-in)	1,930 (6' 4")
D mm (ft-in)	7,805 (25' 7")
E mm (ft-in)	5,265 (17' 3")
F mm (ft-in)	3,980 (13' 1")
H mm (ft-in)	3,000 (9' 10")
I mm (ft-in)	417 (1' 4")
K mm (ft-in)	3,300 (10' 10")
L mm (ft-in)	2,450 (8')
M deg	50
N deg	50

## HYUNDAI CONSTRUCTION EQUIPMENT

### Head Office(Sales Office)

3F, Bundang First Tower, 55 Bundang-ro, Bundang-gu, Seongnam-si, Gyeonggi-do, 13591, Korea

### Americas Operation : Hyundai Construction Equipment Americas, Inc.

6100 Atlantic Boulevard Norcross Ga 30071 U.S.A  
TEL (1) 847-678-823-7802 FAX (1) 847-678-823-7778

### Europe Operation : Hyundai Construction Equipment Europe N.V.

Hyundailaan 4,  
3980 Tessenderlo, Belgium  
TEL (32) 14-56-2200 FAX (32) 14-59-3405

### PLEASE CONTACT