

Masted forklifts
trucks

MC 60/70 T
POWERSHIFT

Heavy duty yard forklifts

- Capability 6000 kg and 7000 kg
- Lifting height of 3.60 m to 4.50 m
- 2 wheel drive
- Motorization Turbo Euro III



 **MANITOU**

MC 60/70 T, heavy duty yard forklifts

Whatever the load and the state of the ground, MC 60/70 T trucks give top quality performance. MANITOU, the expert in rough-terrain handling, has put its experience into yard handling.

● Performance and stability

The MCs 60/70 are powerful trucks with a Perkins (1104 D 44 T) engine giving 95 hp/70 kW, and torque converter transmission for working on any kind of ground.

Low pressure tyres, a differential lock and an oscillating rear axle give superb performance and prevent damaging the ground. Wide diameter wheels combined with high ground clearance allow obstacles (rails, rough terrain, pot-holes etc.) to be crossed in complete safety.



● Fast and flexible working



The Powershift gearbox with electronic gear selector optimises cycle times.



There is progressive gear change carried out under torque for fast operation.

Driving is kept flexible by the EGS system which automatically adjusts the engine speed in accordance with the gear selected.

Masted POWERSHIFT MC 60 /MC 70

MASTS		TYPE	LIFTING HEIGHT ON FORKS (mm)	OVERALL HEIGHT MAST LOWERED (mm)	FREE LIFT ON FORKS (mm)	OVERALL HEIGHT MAST EXTENDED (mm)	HEIGHT AT MAX. CAPACITY (mm)		CAPACITY AT MAX. HEIGHT (kg)		MAST TILTING ANGLE FRONT/REAR
							With side shift carriage	Without side shift carriage	With side shift carriage	Without side shift carriage	
DUPLEX	3.60 m	MC 60 T Powershif	3670	3205	-	5005	3600	3600	5400	6000	15°/15°
		MC 70 T Powershif					3600	3600	6300	7000	
TOTAL	4.00 m	MC 60 T Powershif	4070	3405	-	5405	4000	4000	5400	6000	15°/15°
		MC 70 T Powershif					4000	4000	6300	7000	
VISIBILITY	4.50 m	MC 60 T Powershif	4570	3655	-	5905	4000	4000	4950	5500	15°/15°
		MC 70 T Powershif					4000	4000	5850	6500	

MC 60 /MC 70 T POWERSHIFT Tyres

	Version		Casing	Tyre width (mm)	Overall width with tyres (mm)	
Fitted as standard	All-purpose	Front	18 R 19.5 XF Tubeless (445/65 R 19.5)	450	2150	
	Industrial	Rear	265/70 R19.5 136/135 M HSR1	240	1820	
Optional fitting	All-purpose	Front	18 R 22.5 XF Tubeless (445/65 R 22.5)	450	2150	

Load charts MC 60/MC 70 Powershift

MC 60 T Powershift (without Side shift carriage)

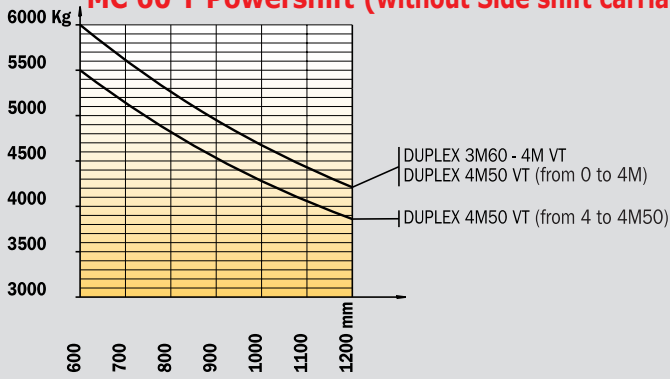

MC 60 T Powershift (with Side shift carriage)

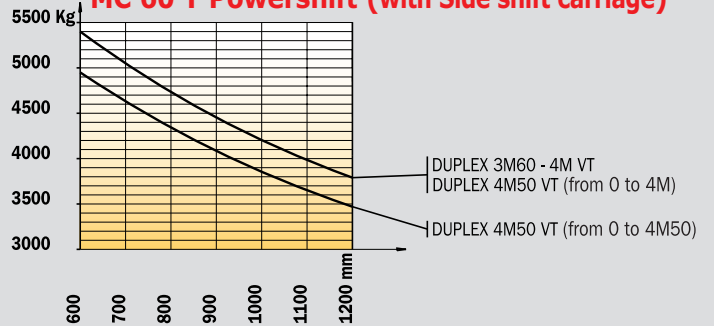

MC 70 T Powershift (without Side shift carriage)

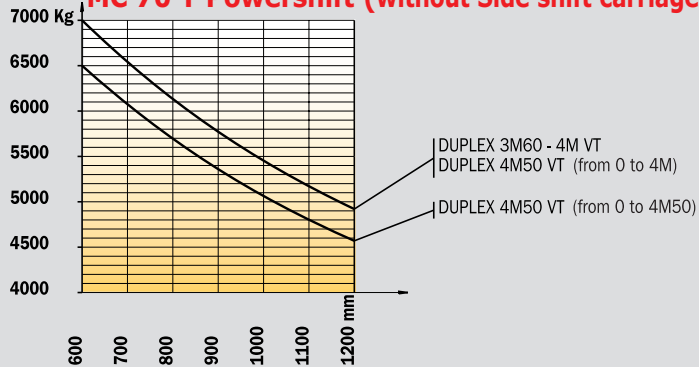

MC 70 T Powershift (with Side shift carriage)

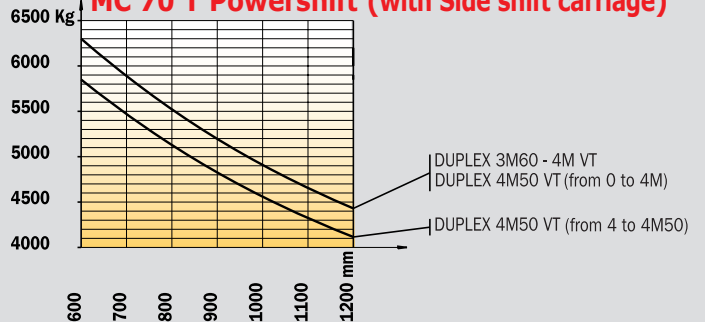

Equipment

STANDARD EQUIPMENT

- Carriage 1260 mm (FEM III)
- Complete cab with side doors
 - Tinted windscreen and rear window
 - Front and rear wipers
 - Front windscreen washer
 - Fabric seat
 - Safety belt
 - Heating
 - Tiltable steering column
- Road lighting adjustment
- Quick-release couplings
- Load shock absorber
- Balancing valve on tilt cylinders
- Battery cut-off switch
- Cyclonic prefilter

OTHER OPTIONAL EQUIPMENT

Mast and accessories :

- Wide choice of forks
- Different carriage sizes

- Load back rest
- Hydraulic outlets for accessories
- Side-shift carriage
- Tiltable carriage with mechanical lock
- Fork positioners
- Rehandling, earth moving or concrete bucket

Cab and driver comfort :

- Air-conditioning
- More comfortable seat (skai or pneumatic)
- Sliding door bay
- Roof wiper
- Sun visor on roof window and windscreen
- Document holder
- Car radio

Safety :

- Rotating lamp
- Internal and external rear-view mirror adjustment
- Working lights (front or rear)
- Back-up alarm buzzer
- Foam inflation
- Emergency circuit-breaker
- Anti-theft systems

Difficult environment and medium :

- Differential lock (2 wheel drive)
- Wide choice of tyres (multipurpose, all terrain...)
- Wing extensions
- Self-cleaning prefilter

Cold countries :

- Diesel heater
- Battery for cold conditions

Special offers (some examples) :

- Specific accessory
- Spark-guard

...

● Quality and reliability

The solid bloc welded chassis is designed to withstand stress and damage.

The cab complies with international safety standards.

The high quality design and the rigorous selection of components guarantee the truck's reliability and long life.



● Driving comfort

The driver's compartment in the MC 60/70 T gives spacious comfort with a panoramic view. The cab's large size combined with the ergonomically designed position of the control levers make driving these trucks a pleasure.

The overall design of the MC range complies with demands for safety with good forward, side and rear vision. And the roof screen gives good vision upwards.

The Powershift control on the steering column enables working speeds to be easily controlled, and the control levers are located in a logical position near the seat.



The MC range includes models from 3 to 7 tonnes.

MC 60 T Powershift MC 70 T Powershift



Lifting capability

MC 60 T Powershift6000 kg
MC 70 T Powershift7000 kg
600 mm from the forks



Standard lifting height :

4.00 m
Speed empty/ laden (m/s)
MC 60 T Powershift
Lifting0.4/0.4
Lowering0.4/0.5
MC 70 T Powershift
Lifting0.4/0.3
Lowering0.4/0.4



Tyres

Front18 R 19.5 XF Tubeless (445/65 R 19,5)
Rear265/70 R19.5 136/135 M HSR1



Forks (mm)

Length1500
Width x thickness150x70



Hydraulic oil bath multidisk brakes on the front axle



Engine PERKINS Euro III

Type1104 D - 44 T
Capacity4 cyl. - 4400 cm³
Nominal engine speed2200 r.p.m.
Power at (ISO/TR 14396)70 kW (95 HP)
Maximum torque392 Nm at 1400 r.p.m.
Direct injection
Water cooled
Travelling up a slope when unloaded/loaded
MC 60 T18%/55%
MC 70 T21%/45%



Transmission

.....Powershift
Electro-hydraulic reversing shift
4 forward and 3 reverse gears
Maximum travelling speed24 km/h
Electro-hydraulic differential lock



Hydraulic

Main gear pump :
Pressure/flow230 bar/85 l./mn
Priority flow divider
for steering145 bar/85 l./mn



Capacity

Cooling system14.5 l.
Engine oil8.5 l.
Hydraulic oil108 l.
Transmission oil12.5 l.
Fuel115 l.



Weight (with forks)

MC 60 T Powershift9175 kg
MC 70 T Powershift9820 kg

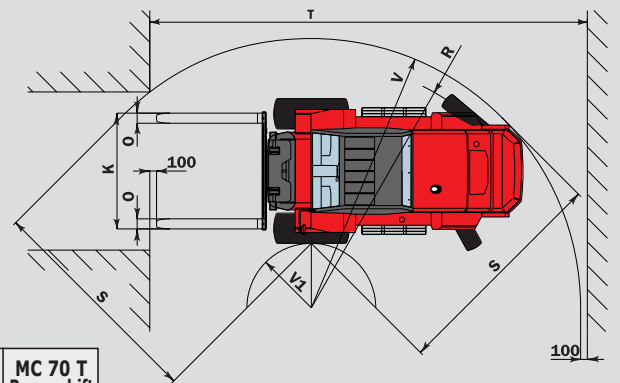
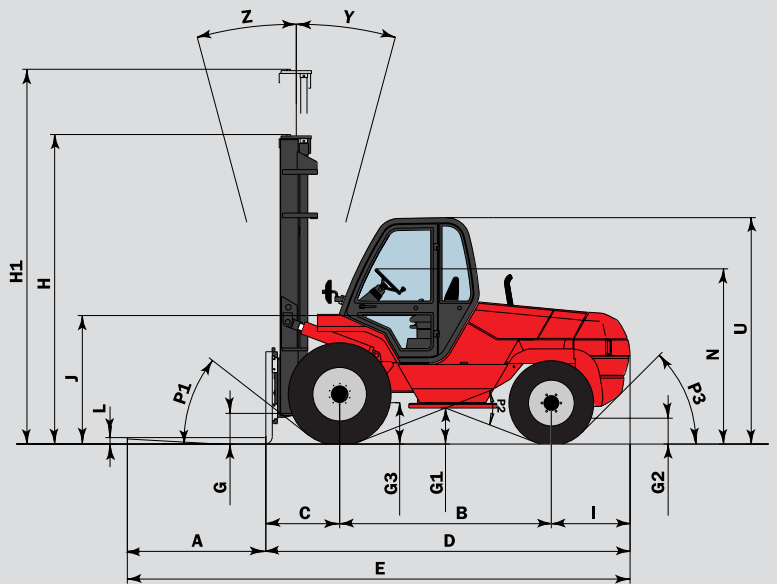

	MC 60 T Powershift	MC 70 T Powershift
A	1500	1500
B	2293	2493
C	803	803
D	3960	4160
E	5460	5660
F	1700	1700
F1	1580	1580
G	320	320
G1	390	385
G2	305	305
G3	390	390
H	3405	3405
H1	5405	5405
I	864	864
J	1390	1390
K	1750	1750
L	70	70
N	1860 at 1920	
O	150	150
P1	38°	38°
P2	42.5°	38.5°
P3	45°	45°
R	3625	3840
S	3460	3510
T	6500	6715
U	2440	2440
V	3995	4210
V1	760	995
W	2150	2150
Y	15°	15°
Z	15°	15°

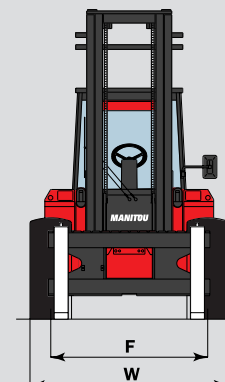
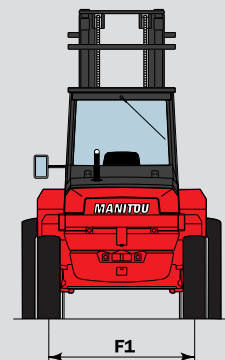

Doc-BE-474 Ind A/Doc-BE-475 Ind A

The equipment supplied with each model may differ from that described in this leaflet.
For more details, contact your MANITOU dealer.

mm
H-H1: Standard



MANITOU BF SA

B.P. 249 - 44158 Ancenis Cedex - France
Tel. : 33 2 40 09 10 11 / Export Department Fax : 33 2 40 09 10 97
www.manitou.com

700130EN-B - 10/08

