

Reach truck

Reach truck. AC motors powerful and silent, full-free-view mast lifting from 4.200 to 10.500 mm (standard). integrated side shift, tilting on fork holder plate (Tilting Forks), electrical servo-steering wheel, steering column multiple adjustable, LCD display with 3 different power output possibilities: E (Economy) S (Super) P (Power). Proportional control for all hydraulic functions by finger tip. It is characterized by its handiness and compact dimensions, suitable for all commodity uses. Possibility to install batteries (48 V 775 Ah) for an intensive use in more than one shift.

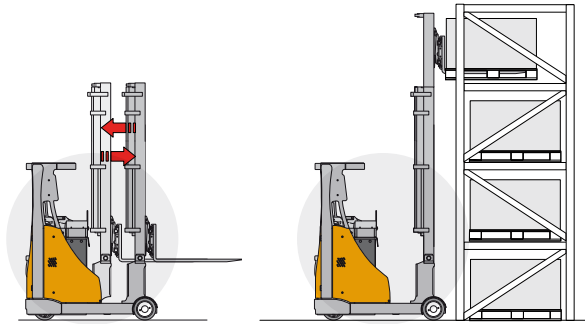

OMG S.p.A.
 via dell'Artigianato, 12
 46023 - GONZAGA (MN) Italy
 Tel. + 39 0376 52.60.11
 Fax. + 39 0376 58.80.08
 www.omgindustry.com
 info@omgindustry.com



Characteristics			OMG S.p.A.
1.1	Manufacturer		NEOS II 20 AC
1.2	Manufacturer's model designation T = integrated side-shift		T
1.3	Drive : E (electric)		E
1.4	Type of control : S (steering wheel) R (seated)		S / R
1.5	Load capacity	Q (t)	2.0
1.6	Load centre distance	c (mm)	600
1.8	Load distance, centre of drive axle to fork Mast advanced	X (mm) X1 (mm)	425 220
1.9	Wheelbase	Y (mm)	1.470
2.1	Service weight (battery included)	Kg	3.840
2.3	Axle loading mast retracted (without load)	front / rear	2.452 / 1.388
2.4	Axle loading mast advanced (with load)	front / rear	675 / 5.165
2.5	Axle loading mast retracted (with load)	front / rear	2.215 / 3.625
3.1	Tyres : vlk (vulkollan) se (superelastic)		vlk
3.2	Front wheels size	mm	343
3.3	Rear wheels size	mm	350
3.5	Wheels : number front / rear (x = traction)		1x / 2
3.7	Rear track width	b 11 (mm)	1.182
4.1	Mast / fork carriage tilted forward / backward	α / β	3 / 5
4.2	Lowered mast height	h1 (mm)	2.655
4.3	Free lift	h5 (mm)	2.130
4.4	Lifting height	h3 (mm)	5.965
4.5	Extended mast height	h4 (mm)	6.620
4.7	Overhead guard (cab) height	h6 (mm)	2.100
4.8	Seat height	h7 (mm)	1.050
4.10	Height of wheels arm	h8 (mm)	225
4.19	Total length	l1 (mm)	2.470
4.20	Length to forks face	l2 (mm)	1.320
4.21	Overall width	b1 / b2 (mm)	1.270
4.22	Forks dimensions	s / e / l	40 / 120 / 1.150
4.23	Fork carriage, class / type A, B		II A
4.24	Fork carriage width	b5 (mm)	840
4.25	Width over forks	b3 (mm)	720
4.26	Distance between support arms / loading surfaces	b4 (mm)	948
4.28	Reach distance	l4 (mm)	655
4.32	Ground clearance	m2 (mm)	75
4.33	Aisle width with pallets 1000 x 1200 forking side 1200	Ast3 (mm)	2.775
4.34	Aisle width with pallets 800 x 1200 forking side 800	Ast3 (mm)	2.812
4.35	Turning radius	Wa (mm)	1.740
4.37	Length across wheel arms	l7 (mm)	1.970
5.1	Travel speed	laden / unladen	Km / h 13 / 13
5.2	Lifting speed	laden / unladen	m / s 0.35 / 0.5
5.3	Lowering speed	laden / unladen	m / s 0.5 / 0.45
5.7	Gradient performance		%
5.8	Max gradient performance		% 13 / 20
5.9	Acceleration time (10 m)		s 6 / 5.6
5.10	Service brake M (mechanical) I (hydraulic) IV (inversion braking)		I / E
6.1	Traction motor, rating S2 60 min	KW	6.5
6.2	Lifting motor, rating S3 15%	KW	15
6.3	Battery according DIN 43531 / 35 / 36 A, B, C, no		no
6.4	Battery voltage, nominal capacity K5	V / Ah	48 / 620
6.5	Battery weight (± 5 %)	Kg	950
	Battery dimensions l / w / h	L/W/H mm	1.220 / 346 / 770
8.1	Type of travel control		INVERTER
8.2	Operating pressure for attachments	bar	180
8.3	Oil volume for attachments (max available)	l / min	25
8.4	Sound level at driver's ear	dB (A)	< 70

Technical specification according VDI 2198

Information and data are given for information only, OMG S.p.A. will have the sole right for technical changes and improvements without giving any notice.

multi function mono joystick	o	LED display lift height indicator	o
flashing beacon	o	manual level pre-selector for 5 levels	o
reverse buzzer	o	video camera with back/white monitor on cab	o
tilting forks	s	complete cabin	o
LCD display	s	cold store execution	o
BDI/hour meter with lifting cut-off at 80% discharge	s	heating system for cold store execution	o
steering wheel position indicator	s	single battery stand	o
traction speed visualization	s	double battery stand (with wheels)	o
steering mode 180° and 360°	s	side rollers	o
turtle push button	s	working lights	o
side-shift	s	drive-in roof	o
s=standard		o=option	

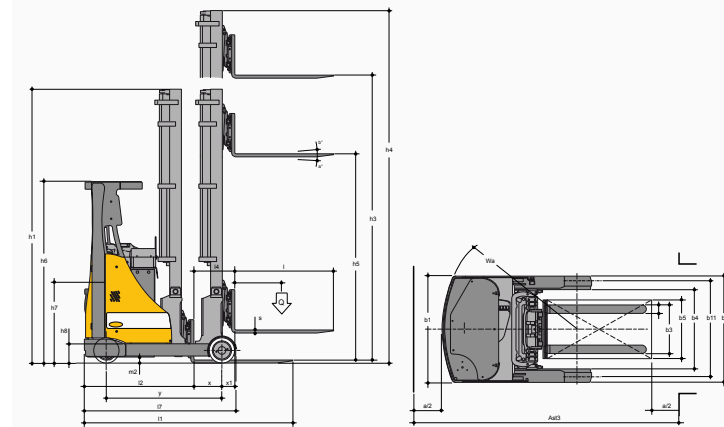

	h3		h1	h4	h5	(Q) t
4.165 tx ffl	mm		2.045	4.820	1.470	2.0
4.465 tx ffl	mm		2.145	5.120	1.575	2.0
5.165 tx ffl	mm		2.390	5.820	1.810	2.0
5.965 tx ffl	mm		2.655	6.620	2.130	2.0
6.665 tx ffl	mm		2.925	7.320	2.360	1.7
7.465 tx ffl	mm		3.185	8.120	2.630	1.6
8.215 tx ffl	mm		3.480	8.870	2.930	1.5
8.965 tx ffl	mm		3.825	9.620	3.280	1.1
9.460 tx ffl	mm		3.900	10.120	3.350	0.9
10.460 tx gal	mm		4.230	11.120	3.680	0.8