

OPTIMUM 1931 AC

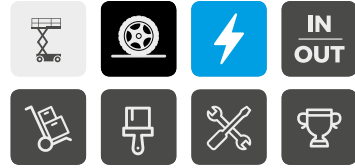

BEST DRIVING AND LIFTING EXPERIENCE

- > AC powered
- > Precision driving control
- > Smooth proportional motions
- > Industry leading turning radius

ULTIMATE VERSATILITY

- > Pass through standard doorways
- > Mobile pothole protection
- > Indoor - outdoor rated

MINIMAL MAINTENANCE AND DOWNTIME

- > Maintenance free AC motors
- > Easy access swing out trays
- > Haulotte Activ'Screen (onboard diagnostics)
- > Smart transportability

LONGER LIFETIME

- > Extreme durability
- > Optimized total cost of ownership

OPTIMUM 1931 AC

ELECTRIC SCISSOR LIFTS

TECHNICAL DATA

OPTIMUM 1931 AC

Working height	24 ft 11 in
Platform height	18 ft 11 in
Driveable at full height up to	18 ft 11 in
Lift capacity - inside	500 lb (2 pers.)
Lift capacity - outside	500 lb (1 pers.)
A Platform length - outside	5 ft 8 in
B Platform length - extended	8 ft 6 in
Extension length	2 ft 10 in
C Platform width - outside	2 ft 5 in
D Height - stowed	6 ft 6 in
F Overall width	2 ft 7 in
G Length	6 ft 3 in
H Wheelbase	4 ft 6 in
I Ground clearance	4 in
Ground clearance - Pothole guards deployed	1 in
Drive speed	0.3 - 2.8 mph
Gradeability	25 %
Tilt alarm	1.5° / 3°
Lift / lower speed	20 s / 29 s
Non-marking tires	12.5 x 4.13
Batteries	24 V - 225 Ah (C20)
Hydraulic system capacity	1.8 gal
Weight	3,500 lb

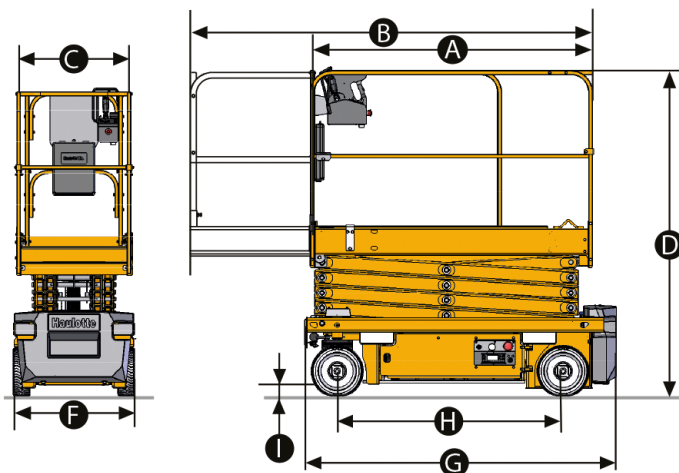

STANDARD EQUIPMENT

- > 24 V electric drive brushless AC motors
- > Battery charge indicator
- > Battery level indicator on upper and lower control boxes
- > Haulotte Activ'Screen (battery charge, Hourmeter, service alert & failures icons in code or in full text...)
- > Pothole guards
- > 2 swing out trays
- > Lateral fork lifting pockets, lifting and tie down points
- > 2 front steering and 2 rear driving wheels
- > Proportional controls
- > Electrical or manual brake release system
- > Tilt sensor
- > AC power to the platform
- > Non-marking tires

OPTIONS AND ACCESSORIES

- > Folding guardrails
- > AC Power to the platform (standard on US machines)
- > Cold weather hydraulic oil
- > Maintenance free batteries
- > Telematics ready
- > Flashing beacon
- > Dual flashing beacons
- > Working light
- > Panel carrier
- > Pipe cradle

