



**Bobcat**®

**T250**

Compact Loaders



## Machine Rating

Rated operating capacity	1168 kg
Tipping load	3338 kg
Pump capacity - T250	80.2 l/min
Pump capacity - T250H	151 l/min
System relief at Quick Couplers	22.4-23.1 MPa
Max. travel speed	10.6 km/h

## Engine

Make / Model	Kubota / V3800-D1T-E3
Fuel / Cooling	Diesel / Liquid
Power	58 kW
Torque at 1500 RPM (SAE J1995 Gross)	298 Nm
Number of cylinders	4
Displacement	3769 cm <sup>3</sup>
Fuel tank capacity	113.5 l

## Weights

Operating weight, T250	4240 kg
Operating weight, T250H	4260 kg

## Controls

Vehicle steering	Direction and speed controlled by two hand levers
Loader hydraulics tilt and lift	Separate foot pedals or optional Advanced Control System (ACS)
Front auxiliary (standard)	Electrical switch on right-hand steering lever

## Drive System

Transmission	Infinitely variable tandem hydrostatic piston pumps, driving two fully reversing hydrostatic motors
--------------	---

## Standard Features

Adjustable suspension seat	Hydraulic bucket positioning
Bob-Tach™ frame	Instrumentation
Bobcat Interlock Control System (BICS)	Lift arm support
Deluxe operator cab	Operating lights, front and rear
Includes interior cab foam, side, top and rear windows	Parking brake
Front door w/ windshield wiper	Seat belt
Cab door	Seat bar
Electrically activated proportional front auxiliary hydraulics	Turbo-charger with approved spark arrestor
Engine/hydraulics system shutdown	Tracks — rubber — 450 mm
	CE certification

\* Roll Over Protective Structure (ROPS) - meets requirements of SAE-J11040 and ISO 3471; Falling Object Protective Structure (FOPS) - meets requirements of SAE-J1043 and ISO 3449, Level I

## Options

Deluxe instrument panel	Advanced Control System (ACS)
Power Bob-Tach™	Advanced Hand Controls (AHC)
Cab enclosure with heat	Selectable Joystick Controls (SJC)
Air conditioning	Roller suspension

## Attachments

- Angle blade
- Angle broom\*†
- Auger
- Backhoe
- Box blade
- Bushcat rotary cutter
- Buckets
- Chipper\*
- Combination bucket
- Concrete pump\*
- Cutter crusher\*
- Digger
- Dozer blade\*
- Dumping hopper
- Farm grapple
- Grader\*
- Hydraulic breaker\*\*
- Industrial grapple
- Landplane
- Landscape rake
- Mixing bucket\*
- Pallet fork - standard
- Pallet fork - hydraulic
- Planer\*
- Rear stabiliser
- Scarifier
- Snow blower\*
- Sod layer\*
- Soil conditioner\*
- Spreader
- Stump grinder\*
- Super scraper
- Sweeper
- Three-point hitch
- Tiller
- Tilt-Tatch™
- Tracks, steel
- Tree transplanter\*
- Trench compactor
- Trencher
- Utility forks
- Utility frame
- Vibratory roller
- Water kit
- Wheel saw
- Whisker broom

\*Attachment control kit required.

\*\*When operating the loader with this attachment, a Special Applications Kit, which includes a 12 mm Lexan front door with 6 mm top and rear windows, must be used.

†Optional water kit.

## Dimensions

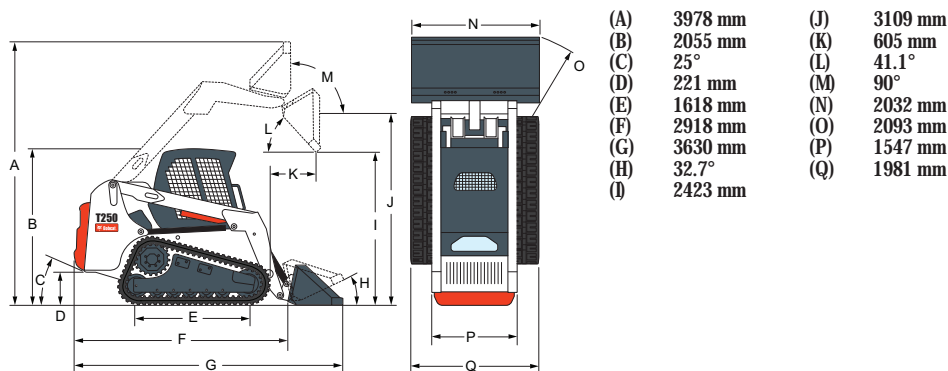

[www.bobcat.eu](http://www.bobcat.eu)