

# Model TOUCAN 8E

## MAST BOOM LIFTS

# JLG®

### MORE ECONOMIC

- Electric power for zero emissions and near-silent running indoors.

### MORE PRODUCTIVE

- No waiting with immediate-response AC drive motors for greater torque and efficiency.

### MORE ACCESS

- Get into more places with compact dimensions and precise control system.

### SMART DESIGN

- Extended reach and up-and-over height with heavy duty forklift-style mast and versatile articulating jib.



### Standard Features

- 0.85 m x 0.92 m (L x W) steel platform
- Slide bar rear entry
- Full proportional drive and slew joystick control with integral thumb steer switch
- Mini joysticks provide proportional mast and jib lift/lower functions
- 1.17 m articulating jib
- Load sensing system
- AC power cable to platform
- Large tool tray
- Two wheel direct electric drive
- Brushless AC drive motors
- Auto power save when idle
- Low charge function cut-out
- On-board diagnostics with integral display
- Automatic rear wheel brakes
- Sculptured polyester hoods
- Heavy duty steel roller mast with 345° rotation
- Chain slack detection system
- 2,5 degree tilt alarm and indicator light
- Passive pothole protection system
- 0.99 m wide frame
- Lifting /tie down rings
- Ground control selector switch with key lock
- Battery discharge indicator
- Hour meter
- Horn
- Drive orientation system
- Lanyard anchor points
- Zenon strobe light
- Manual descent system

### Standard Specifications

- |                             |                 |
|-----------------------------|-----------------|
| • Tyres (non-marking solid) | 406 x 125 mm    |
| • Electrical system         | 24V DC          |
| • Batteries (AGM)           | 24 V - 213 A/hr |
| • Charger                   | 24V - 27A       |
| • Drive motors              | Dual AC motors  |
| • Electrical (pump) motor   | 3kW 24V DC      |
| • Hydraulic system          | 7.5 L           |

### Accessories & Options

- 8 mm air line to platform
- Acoustic motion alarm
- Food Compatible Hydraulic Oil
- Low Temperature Hydraulic Oil
- Platform Power Plug & Socket <sup>1</sup>
- Platform work lights 70W
- Synthetic Biodegradable Hydraulic Oil
- Special paint colour

<sup>1</sup> Included with circuit breaker on AC cable to platform option. NB 110V or 230V power must be specified

# Model TOUCAN 8E

## MAST BOOM LIFTS

### Performance

- Working height 8.20 m
- Working outreach (standard platform) 2.65 m
- Up and over height 5.08 m
- Swing (not continuous) 345°
- Platform capacity <sup>1</sup> 200 kg
- Jib - overall length 1.17 m
- Jib - range of articulation 112° (+45°/ -67°)
  - A. Platform size standard platform (L x W) 0.85 x 0.92 m
  - B. Overall width 0.99 m
  - C. Tailswing 17 cm
  - D. Stowed height 1.99 m
  - E. Overall length (standard platform) 2.10 m
  - F. Wheelbase 1.20 m
  - G. Ground clearance 10 cm
- Machine weight - standard platform <sup>2</sup> 2,100 kg
- Maximum ground bearing pressure 17,2 kg/cm<sup>2</sup>
- Drive speed - lowered 5.5 km/h
- Turning radius (outside) 1.99 m
- Turning radius (inside) 0.55 m
- Gradeability 25%

<sup>1</sup> Capacity shown is maximum two persons indoor and outdoor (12.5 m/s wind speed)

<sup>2</sup> Certain options or country standards may increase weight and/or dimensions.



### Reach Diagram

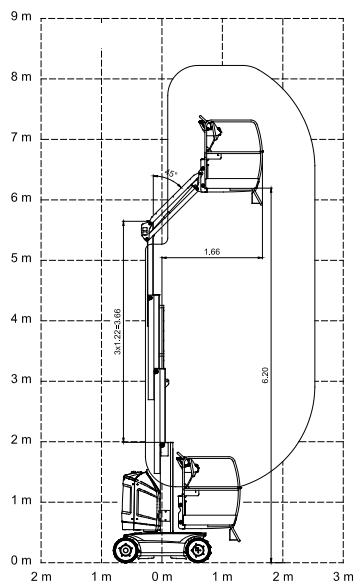

### Dimensions

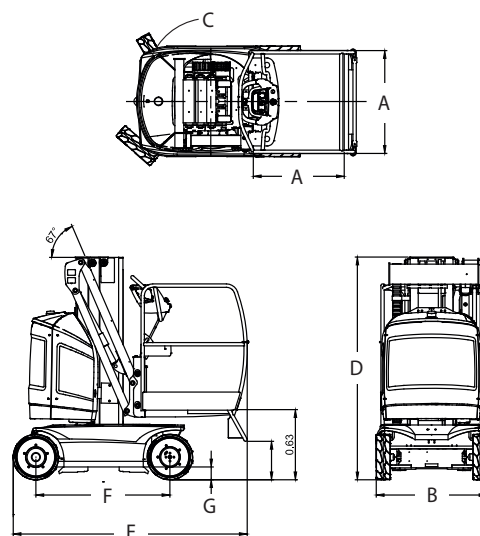

### IMPORTANT

JLG is continually researching and developing products and reserves the right to make modifications without prior notice. All data in this document is indicative. Certain options or country standards will increase weight. Specifications may change to meet country standards or with the addition of optional equipment.

Due to continuous product improvements, JLG Industries reserves the right to make specification and/or equipment changes without prior notification.

# JLG<sup>®</sup>

## JLG EMEA BV

Polaris Avenue 63  
2132 JH Hoofddorp  
The Netherlands  
Tel: +31 (0)23 565 5665  
Fax: +31 (0)23 557 3750  
[www.jlg.com](http://www.jlg.com)

An Oshkosh Corporation Company