

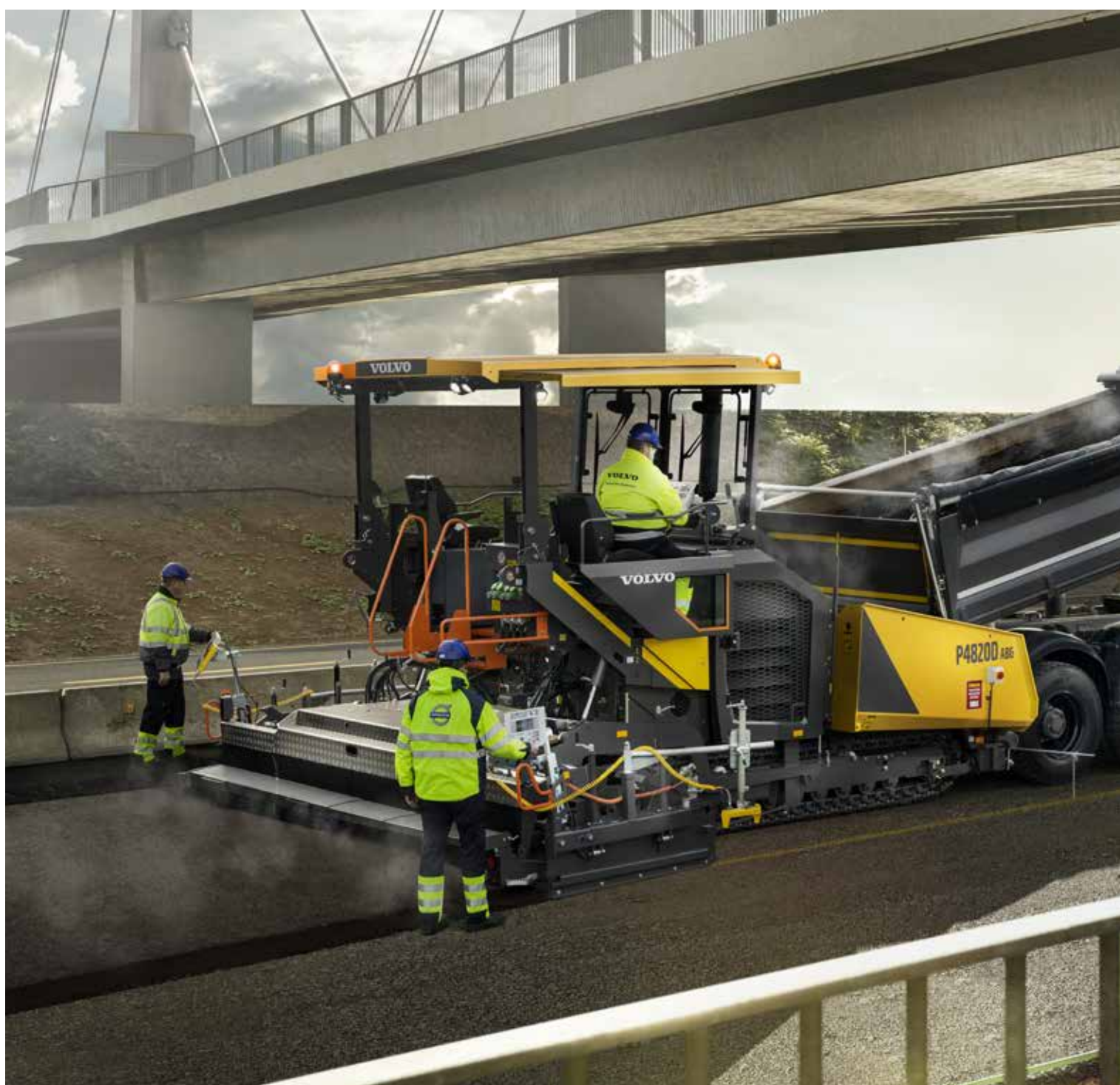

Volvo Construction Equipment

P4820D ABG

Volvo Tracked Pavers 2.5-6.5 m 96 kW





COMPACT MACHINE, BIG FEATURES

The P4820D ABG is the smallest 2.5 m track paver in Volvo's paver offering and its compact design allows transporting with a compactor on the same vehicle for example. Powered by a fuel efficient Volvo engine, it's the first Volvo paver with the new EPM 3 control system.

From inner city to intercity

This compact machine includes features from larger Volvo pavers, allowing it to handle both small inner-city jobs and intercity projects. It can pave from 2.5 m – 6.5 m - it's a small, compact machine with big potential.

Different applications

This highly versatile paver can turn its hand to any application whether it's paving walkways, parking areas, private drives, inner and intercity roads, national roads and even highways. The P4820D ABG is easily manoeuvrable and uses the latest advanced paver technology, making it perfect for a variety of jobs.



Transport configuration with foldable roof and exhaust pipe

The length and weight of this machine makes it possible to transport other equipment on the same vehicle. To obtain a lower transport height, the roof together with the exhaust pipe is easily raised and lowered. This avoids deviation when travelling through bridges or tunnels on the way to your job site.



Undercarriage and automatic track tensioner

Built to last, Volvo's longer undercarriage design on the P4820D ABG – with automatic track tensioning system – has been improved for added reliability. The new style bolt-on rubber track pads option with a lube-for-life track chain provides greater ground contact compared to competitive brands.



Large hopper

The large hopper capacity provides uninterrupted material supply that keeps the paver moving at a constant speed reducing stops and starts for a smoother finish. A hydraulic front apron assists with emptying the front area of the hopper to avoid spillage and manual cleaning.



Control with ease

A highly advanced, electronic paver management system optimises the paver for your specific application and increases overall machine control so you can focus on the job. Its ergonomic design increases operator comfort and safety when moving around the machine.

Operator platform & visibility

The operator has full, unhampered visibility around the paver, hopper, auger channel and screed, for a clearer view, increasing performance and paving quality. The comfortable control area reduces operator fatigue for longer and more focused operation. The level platform reduces the risk of tripping and the anti-skid deck plating and hand rails provide stability when walking around the machine.



Settings Manager

The settings manager feature allows you to store and save customised settings for individual projects, achieving consistent quality from job-to-job. When encountering similar paving projects, the operator can recall saved parameters within the EPM 3, simplifying the initial machine set-up to quickly begin paving. Once paving is underway fine tuning can be made to optimize performance and productivity.



The perfect assistant

Unlock the full potential of your machine's productivity with Pave Assist, designed specifically for Volvo pavers. Pave Assist provides a powerful set of tools - including Thermal Profiling, Weather View and Material Manager - to improve performance, efficiency and paving quality.



Sound protection

Volvo pavers are designed to perform on a remarkable low noise level. Paver noise level lowers even further when the default Eco Mode is in operation. This is especially useful in busy city environments or residential areas where noise constraints are in place.





ELECTRONIC PAVER MANAGEMENT 3

The new highly advanced, third generation Electronic Paver Management 3 (EPM 3) control system provides the operator with total paver control. The unique control panel guides the operator intuitively through individual working functions. Control buttons for all functions are arranged on a bird's eye diagram associating them with actual machine locations. Gain superior control over your machine's functions.



VOLVO POWERTRAIN

Volvo's pavers feature Volvo designed and built Powertrain components, which have been created to work together. Thanks to years of development, the Volvo powertrain offers unrivalled durability and performance for increased uptime, as well as longer component life and high fuel efficiency.

Pave the way in fuel efficiency

Volvo champions intelligent technology that reduces fuel consumption and enhances your machine's efficiency while reducing noise. A number of features work together to lower operating costs thereby increasing profits.

Eco Mode & fuel monitoring

The new Volvo electronic intelligent system features the default Eco Mode to match engine output during paving, which will extend engine and component life. Eco Mode reduces fuel usage up to 30% for more effective paver. The EPM 3 monitors average fuel consumption, shows daily fuel usage as well as remaining fuel run time.



Improved high efficiency hydraulic system

The paver hydraulic system is perfectly matched to the Volvo engine to provide high performance, low fuel consumption, emissions and noise levels. Controlling your RPMs in an intelligent way results in a highly efficient machine but yet maintaining plenty of reserve power to handle the toughest application with ease. The hydraulic system generates the same powerful performance while using less fuel.



Hydraulic cooling fan

The hydraulically driven, electronically controlled cooling fan regulates its speed as necessary resulting in lower fuel consumption and sound levels.

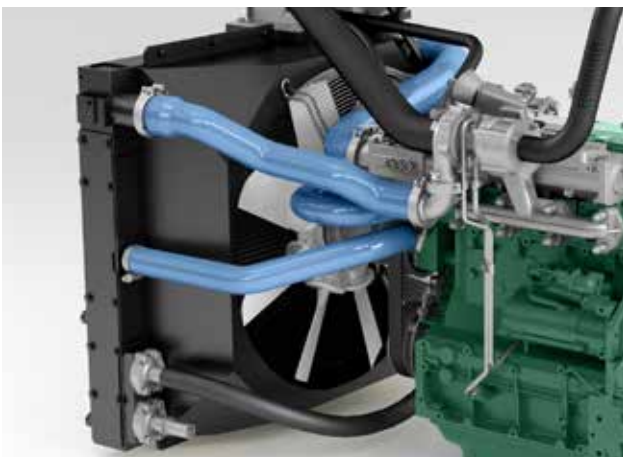

Volvo engine

Volvo engines are powerful and efficient, designed to reduce fuel consumption and increase your productivity. With advanced technology, save your business time and cost.



A small machine with big potential

COMPACT MACHINE, BIG FEATURES

The P4820D ABG is the smallest 2.5 m tracked paver in Volvo's paver offering. Its compact design allows transporting with additional equipment.

Service Interval Manager

The EPM 3 displays an automated management system that notifies the operator of scheduled maintenance.

MATRIS

MATRIS supports optimized operation by tracking activity characteristics and identifying opportunities for improvement.

Large hopper

The large hopper capacity provides uninterrupted material supply that keeps the paver moving at a constant speed, reducing stops and starts for a smoother finish.

CARETRACK ADVANCED

Stay informed, receive reports, alarms and information such as fuel status, machine location and hours to plan your service more efficiently.

Bolt-on rubber pads and lube-for-life chain

New Volvo branded durable rubber pads are wear and tear resistant, easily replaced as well cost effective.



Operator platform and visibility

The operator has full, unhampered visibility around the paver, hopper, auger channel and screed, for a clearer view, increasing performance and paving quality.



VOLVO POWERTRAIN

Volvo Powertrain offers unrivalled durability and performance for increased uptime, as well as longer component and engine life for high fuel efficiency.

ELECTRONIC PAVER MANAGEMENT 3

The new highly advanced, third generation Electronic Paver Management (EPM 3) control system provides the operator with total paver control.

Settings Manager

The settings manager feature allows you to store and save customised settings for individual projects, achieving consistent quality from job-to-job.

Eco Mode and fuel monitoring

The default Eco Mode matches engine output to demand resulting in up to 30% fuel savings while extending engine and component life.

SCREED EFFICIENCY

The Volvo ABG designed screed heats up evenly and quickly up to three degrees every minute. This provides improved fuel efficiency and faster start up times.



CARETRACK ADVANCED

CareTrack is the state-of-the-art telematics system designed for Volvo Construction Equipment. Stay informed, receive reports, alarms and information such as fuel status, machine location and hours so you can plan your service more efficiently. Stay ahead of unscheduled downtime and check that your machine is being operated efficiently.

State-of-the-art service

To keep your machine efficient and increase its longevity, Volvo offers a number of features for regular, quick and easy serviceability that will increase component and machine life. With the Volvo engine, a one stop shop is provided for all your service and maintenance needs.

Service Interval Manager

The EPM 3 can display an automated management system that notifies the operator of required or scheduled maintenance. It alerts you to routine service, daily checks, longer interval service requirements and any overdue maintenance. The system stores information and retains a service history record.



Bolt-on rubber pads and lube-for-life chain

New Volvo branded durable rubber pads are wear and tear resistant, easily replaceable as well as cost effective. The lube-for-life chain increases track service intervals and reduces track noise when traveling.

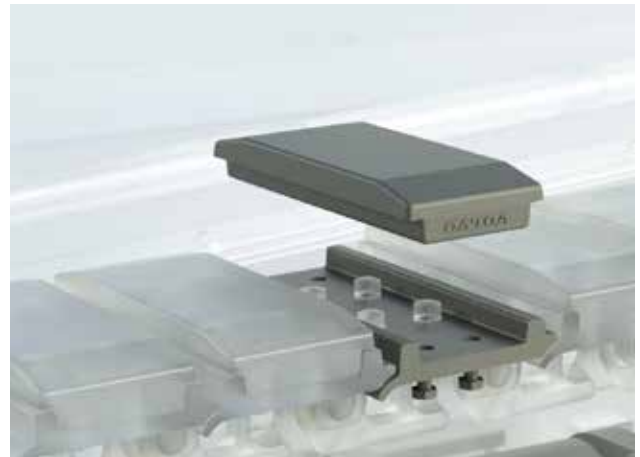

Service access

Improved service access from the platform provides ease of maintenance, reduces downtime and minimizes operational costs. All daily routine maintenance and fuelling can be performed quickly from the platform saving the operator both time and effort.



MATRIS

Volvo dealers can provide expert analysis of machine operating activity via this tool. MATRIS supports optimized operation by tracking activity characteristics and identifying opportunities for improvement – resulting in better economy and reduced wear.



Industry leading screeds

Volvo screeds are designed to give you the best pavement quality, uniformity and smoothness. Versatile and effective in paving widths up to 16 meters, these industry-leading screeds can handle a wide range of materials. Thanks to achieving a maximum degree of pre-compaction rolling work is significantly reduced.

Screed control unit and levelling control

Two screed mounted control units provide operators with easy access to the screed and adjustment settings. The Screed Control Unit (SCU) allows the operator to easily control the functions of the screed and material flow. The newly designed SCU is flexible and can be rotated in any direction for easier operator use.



Unique quick coupling

Extensions are added or removed in minutes, with no special tools required, thanks to Volvo's quick coupling system. It takes less time to set up, saving time and money. The system enables the paving crew to quickly attach or remove extensions to meet various jobsite requirements.



Tamper bar

The screed tamper bars can be electrically heated for better performance and a smooth finish. The fully hardened tamper bar significantly extends the life time of the component. Tamper bars are easily replaced, which saves money and increases uptime.

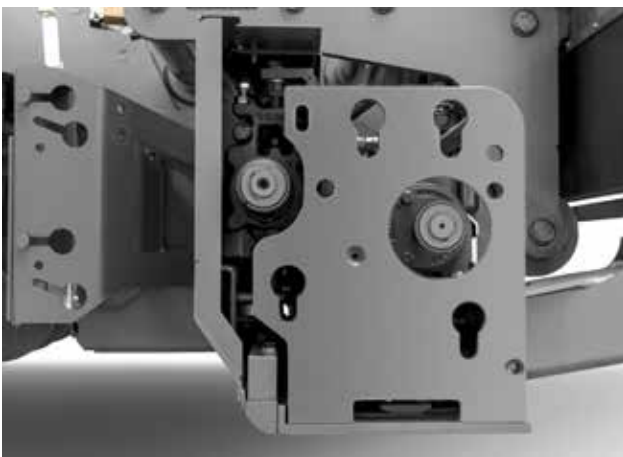

Four guide tubes

Volvo screeds have four guide tubes for each hydraulic extension. The rigid tubes work together to prevent the screed extensions from twisting when high forces are exerted on them. This produces a consistent, uniformly compacted smooth surface.

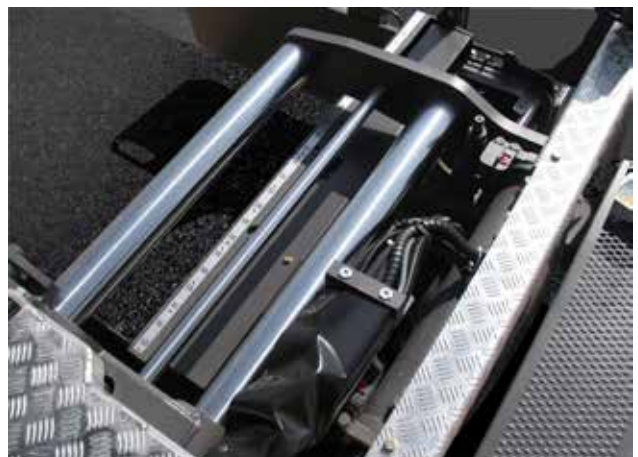



SCREED EFFICIENCY

The Volvo ABG designed screed heats up evenly and quickly up to three degrees every minute. This provides improved fuel efficiency and faster start up times. The robust screed design produces a consistent, high quality mat that increases productivity.

Specifications

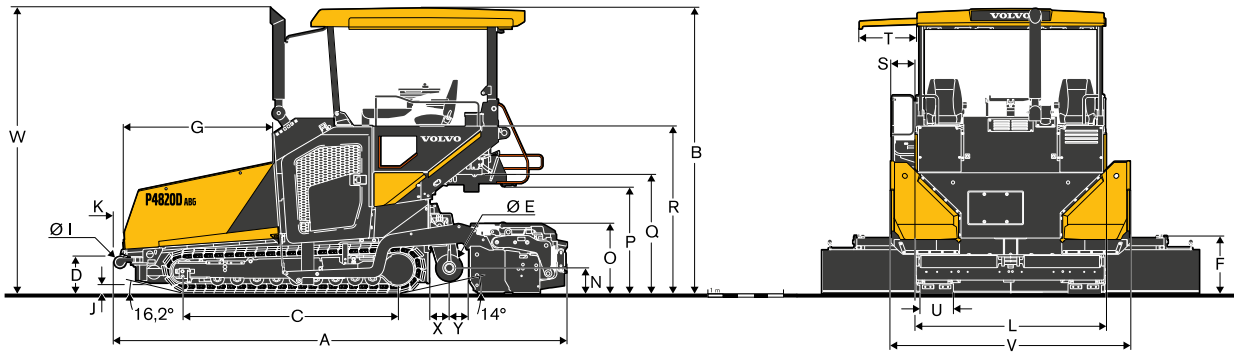

Engine	
Manufacturer	Volvo
Model	D4E
Fuel	Diesel
Output	kW 96
	hp 131
at engine speed	r/min 2 200
Coolant	Liquid
Fuel tank capacity	l 180
Exhaust emission	Stage IIIA / Tier 3

Paving	
Output (theoretical)*	t/h 500
Mat thickness (max)	mm 300

Speed	
Paving (max)	m/min 20
Transport (max)	km/h 3.6

Undercarriage	
Length	mm 2 850
Width (track plates)	mm 300

Conveyor	
Hopper capacity	t 12.5
Number of conveyors	2
Conveyor speed (max)	m/min 14

Auger	
Speed (max)	1/min 68
Diameter	mm 360

Electrical system	
Battery voltage	V 24

Dimensions	
Length with Vario Screed (Walkway up)	mm 5 997
Width	mm 2 532
Height	mm 2 917

Weight**	
Tractor unit	kg 12 280

Max. allowable gradeability***	
Tractor unit + screed	% 25

Sound Level	
Sound Pressure Level at Driver's Ear, acc. to ISO 11201	
LpA	dB(A) 79 (with VB78, VB79, VB88,VB89 screeds)
Guaranteed Sound Power Level, acc. to Directive 2000/14/EC	
LwA	dB(A) 104 (with VB78, VB79, VB88,VB89 screeds)

Notes

*The actual paving output depends upon the mat thickness, the paving width and paving speed and will vary according to paving conditions prevailing on your jobsite. Please approach us and we will be pleased to assist you in calculating the paving output for your particular paving project.

** All weights are approx. weights without options. Weight of the tractor: Diesel tank half-full, continuous towing arms, 75kg operator and weather roof included.

***Applies to screed VB 78 2.5-5.0 m. When using extensions the max. allowable gradeability will be reduced.

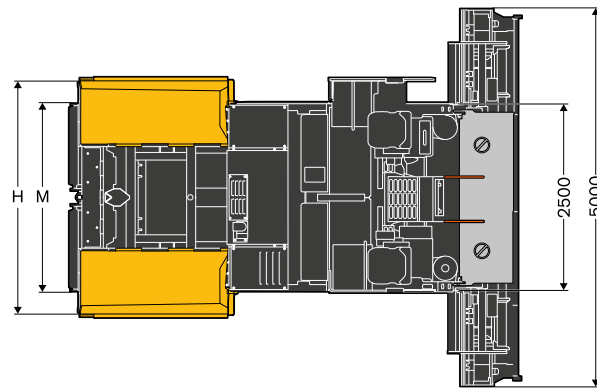

DIMENSIONS

Unit	mm
A	5 997
B	3 785
C	2 850
D	525
E	360
F	748
G	2 019
H	3 091
I	160
J	155
K	141
L	2 548
M	2 495
N	360 ± 60
O	939
P	1 440
Q	1 608
R	2 235
S	311
T	770
U	300
V	open 3 191
	closed 2 532
W	3 796
X	275
Y	265

OPERATING WEIGHT¹ OF SCREED IN KG

At working width	5.0 m	6.0 m	6.5 m
VB 78 ETC	3 528	-	5 150
VB 79 ETC	3 730	-	-
VB 88 ETC	-	3 820	-

¹ Including auger extensions, channel plates, end gates.

Equipment

STANDARD EQUIPMENT

Engine

Volvo Diesel engine, EU Stage IIIA /EPA Tier 3

Drive

Electronic drive control

Lifetime lubricated crawler track rollers

Forged and hardened crawler track links

Automatic track tensioner

Bolt on rubber pads

Material Management

Large truck push rollers with 160 mm Ø

Four individual hydrostatic drives for conveyors and augers

Reversible direction of auger rotation

Proportional conveyor sensors

Electronics

Electronic Paver Management (EPM 3)

ECO mode

Settings Manager

Service Interval Manager

Adjustable and revolving control panels at operator platform

Electric switch cabinet

Battery master switch

Two adjustable and revolving screed panels

MATRIS

Structure

Two seats, laterally extendable

Anti-vandalism kit

Volvo Green Key

Screed

Hydraulics for Vario screeds with tamper and vibration

Screed lock

Lights

Six working lights (LED)

Operators platform

Home light function

Environmental

Sound insulation

OPTIONAL EQUIPMENT

Material Management

Individual operating hopper wings

Hydraulically operated front apron

Reversible conveyor

Hydraulic auger height adjustment

Proportional Ultrasonic Sensor auger control

Central lubrication

Light truck push rollers with 110 mm Ø

Protective half shells

Electronics

Levelling systems

Additional sockets 230V

Caretrack Advanced

Pave Assist (Volvo Co-Pilot system)

Volvo Smart View camera system

Smart Dock

Transport case for EPM control panels

Structure

Deluxe seats with heating

Front windscreen

Tarpaulin side curtains for weather roof

Custom colour

Automatic folding device for weather roof (electro-hydraulic)

Screed

Screed anti-climbing lock

Screed assist

Hydraulic height adjustment of extendable screeds

Hydraulically adjustable Power-Float screed end gates

Heatable screed end gates

Lights

10 working lights (LED)

Two additional rear lights (LED)

Auger lighting

Levelling indicator scale lighting

Warning beacons

Environmental

Extractor for bituminous fumes

Emulsion spraying system

Heavy-duty spray cleaning gun

Biodegradeable hydraulic oil

SELECTION OF VOLVO OPTIONAL EQUIPMENT

Hydraulic operated front apron



Central lubrication



Additional lighting



Levelling equipment



Special paintwork



Additional sockets



Not all products are available in all markets. Under our policy of continuous improvement, we reserve the right to change specifications and design without prior notice. The illustrations do not necessarily show the standard version of the machine.

VOLVO

Volvo Construction Equipment

www.volvoce.com